



# Product Catalog

## **Packaged Rooftop Air Conditioners Voyager™ Commercial with ReliaTel™ Controls**

27½ to 50 Tons - 60 Hz

22.9 to 41.7 Tons (81-148 kW) - 50 Hz





# Introduction

## Packaged Rooftop Air Conditioners

Through the years, Trane has designed and developed the most complete line of Packaged Rooftop products available in the market today. Trane was the first to introduce the Micro—microelectronic unit controls—and has continued to improve and revolutionize this design concept.

The ReliaTel™ control platform offers the same great features and functionality as the original Micro, with additional benefits for greater application flexibility.

The Voyager™ Commercial line offers 27½ to 50 ton, 60 Hz and 23 to 42 ton 50 Hz models. Both 50 and 60 Hz models come in a choice of five sizes to meet the changing demands of the commercial rooftop market.

Trane customers demand products that provide exceptional reliability, meet stringent performance requirements, and are competitively priced. Trane delivers with Voyager Commercial.

Voyager Commercial features cutting edge technologies: reliable 3-D™ Scroll compressors, eStage for premium efficiency, Trane engineered ReliaTel controls, computer-aided run testing, and Integrated Comfort™ Systems.

So, whether you're a contractor, the engineer, or an owner you can be certain Voyager Commercial Products are built to meet your needs.

It's Hard To Stop A Trane.®



### Revision Summary

RT-PRC033H-EN (16 Feb 2016)

- Updated Features and Benefits, Selection Procedure, Model Number Description, General Data, Performance Data, Electrical Data, Mechanical Specifications.

# Table of Contents

Features and Benefits .....	8
Standard Features .....	8
Optional Features .....	8
Cabinet .....	8
Controls .....	8
Electrical .....	9
Filtration .....	9
Heat .....	9
Mechanical .....	9
Refrigeration .....	9
Quality and Reliability .....	10
Easy to Install, Service and Maintain .....	10
Rigorous Testing .....	10
ReliaTel™ Controls .....	10
Human Interface .....	11
Conversionless Units .....	11
Drum and Tube Heat Exchanger (Gas Heat Only) .....	11
Low Ambient Cooling .....	12
Microchannel Condenser Coils .....	12
Phase Monitor .....	13
Pressure Cutouts .....	13
Single Point Power .....	13
Sloped Drain Pans .....	13
Temperature Discharge Limit (TDL) .....	13
Outstanding Optional Features .....	13
Variable Frequency Drives (VFD) .....	13
Single Zone VAV – An Ideal Energy Saving Solution for Yesterday’s “Constant Volume” Systems .....	13
Delivered VAV .....	14
VariTrac™ Changeover-Bypass VAV .....	14
Power Exhaust Option .....	14
Fresh Air Tracking Power Exhaust Option .....	14
Statitrac™ Direct Space Building Pressurization Control .....	15
Downflow and Horizontal Economizers .....	15
Trane Air Quality (TraQ™) Outside Air Measurement System .....	15
Interoperability with BACnet (BCI-R) .....	15
Interoperability with LonTalk® (LCI-R) .....	15
Trane Communication Interface (TCI) .....	16
Trane Air-Fi™ Wireless Comm Interface (WCI) .....	16
Modulating Hot Gas Reheat .....	16
Tool-Less Condenser Hail Guards .....	16
Trane Factory Built Roof Curbs .....	16
Motor Shaft Grounding Ring .....	17
Stainless Steel Sloped Drain Pans .....	17
Condensate Overflow Switch .....	17



## Table of Contents

---

eStage - High Efficiency Units .....	17
One of Our Finest Assets .....	17
Application Considerations .....	18
60/50 Hz Units .....	18
Exhaust Air Options .....	18
Application Recommendations .....	18
Altitude Corrections .....	19
Acoustical Considerations .....	20
Clearance Requirements .....	20
Duct Design .....	21
Selection Procedure .....	22
60 Hz Units .....	22
Five Basic Areas .....	22
Cooling Capacity Selection .....	22
Heating Capacity Selection .....	23
Air Delivery Procedure .....	24
Unit Electrical Requirements .....	24
Unit Designation .....	25
50 Hz Units .....	25
Five basic areas .....	25
Cooling Capacity Selection .....	25
Heating Capacity Selection .....	27
Air Delivery Procedure .....	27
Unit Electrical Requirements .....	28
Unit Designation .....	28
Model Number Descriptions .....	29
60 Hz Description .....	29
50 Hz Description .....	31
General Data .....	33
Performance Adjustment Factors .....	44
Performance Data (60 Hz Units) .....	46
Performance Data (50 Hz Units) .....	61
Controls .....	86
VAV Units Only—Sequence of Operation .....	86
Supply Air Pressure Control .....	86
Supply Air Temperature Controls .....	86
Zone Temperature Control .....	87
CV Units Only—Sequence of Operation .....	88
Occupied Zone Temperature Control .....	88
Unoccupied Zone Temperature Control Cooling and Heating .....	89

Single Zone VAV Units Only (SZ VAV)—Sequence of Operation . . . . .	90
Zone Temperature Control . . . . .	90
Heating Operation . . . . .	90
Supply Air Tempering . . . . .	91
Auto Changeover . . . . .	91
Unoccupied Zone Temperature Control Cooling and Heating . . . . .	91
Conventional Thermostat Interface . . . . .	91
Control Sequences of Operation Common to CV, VAV, and SZ VAV . . . . .	92
Ventilation Override (VOM) . . . . .	92
Coil Freeze Protection Froststat™ . . . . .	92
Occupied/Unoccupied Switching . . . . .	92
Space Pressure Control - Statitrac™ . . . . .	92
Night Setback Sensors . . . . .	92
Timed Override Activation—ICS . . . . .	93
Timed Override Activation—Non-ICS . . . . .	93
Comparative Enthalpy Control of Economizer . . . . .	93
Fan Failure Switch . . . . .	93
Emergency Stop Input . . . . .	93
Condensate Overflow Switch . . . . .	93
Electrical Data . . . . .	94
Electrical Service Sizing . . . . .	94
Set 1. Cooling Only Rooftop Units and Cooling with Gas Heat Rooftop Units	94
Set 2. Rooftop Units with Electric Heat . . . . .	94
Dimensional Data . . . . .	99
Fresh Air, Power Exhaust Hoods . . . . .	99
Field Installed Sensors—Variable Air Volume VAV . . . . .	106
Field Installed Sensors—Constant Volume CV or Single Zone Variable Air Volume SZ VAV . . . . .	106
Integrated Comfort™ System Sensors—CV, VAV, and SZ VAV . . . . .	107
Weights . . . . .	110
Mechanical Specifications . . . . .	112
General . . . . .	112
Casing . . . . .	112
Filters . . . . .	112
Compressors . . . . .	112
High Efficiency Unit (eStage) . . . . .	112
Refrigerant Circuits . . . . .	112
Evaporator and Condenser Coils . . . . .	113
Outdoor Fans . . . . .	113
Indoor Fan . . . . .	113
Electric Heaters . . . . .	113
Gas Heating Section . . . . .	113

## Table of Contents

---

Controls .....	113
Control Options .....	114
Variable Frequency Drives (VFDs) .....	114
Ventilation Override .....	114
Trane Communication Interface (TCI) .....	114
LonTalk Communication Interface (LCI-R) .....	114
BACnet Communication Interface (BCI-R) .....	114
Air-Fi™ Wireless Comm Interface (WCI) - Field Installed .....	114
Human Interface .....	114
Outside Air .....	115
Manual Outside Air .....	115
Economizer .....	115
Ultra Low Leak Economizer with Fault Detection and Diagnostic (FDD) .....	115
Outside Air Measurement (Traq™) .....	115
Exhaust Air .....	115
100% Power Exhaust Fan .....	115
50% Power Exhaust Fan .....	115
100% Modulating Exhaust Fan with Statitrac™ Control Option .....	115
100% Fresh Air Tracking Power Exhaust .....	116
50% Fresh Air Tracking Power Exhaust .....	116
Barometric Relief .....	116
Ultra Low Leak Exhaust .....	116
Unit Options .....	116
Clogged Filter Indication .....	116
Comparative Enthalpy Kit .....	116
Condensate Overflow Switch .....	116
Condenser Coil Guards .....	116
Corrosion Protected Condenser Coil .....	116
Discharge Air Sensing .....	116
GFI Convenience Outlet (Factory Powered) .....	117
GFI Convenience Outlet (Field Powered) .....	117
Unit Interrupt Rating (Short Circuit Current Rating-SCCR) .....	117
High Temperature Thermostats .....	117
Hinged Service Access .....	117
Hot Gas Reheat .....	117
LP Conversion Kit .....	117
Modulating Gas Heat .....	117
Motor Shaft Grounding Ring .....	117
Non-Fused Disconnect Switch .....	117
Phase Monitor .....	117
Reference Enthalpy Kit .....	118
Remote Potentiometer .....	118
Roof Curb .....	118
Service Valves .....	118
Single Zone Variable Air Volume .....	118
Stainless Steel Drain Pans .....	118

---

**Table of Contents**

Stainless Steel Heat Exchanger .....	118
Through-The-Base Electrical Provision .....	118
Tool-Less Condenser Hail Guards .....	118
Zone Sensors .....	118



# Features and Benefits

## Standard Features

- R-410A refrigerant
- Factory installed and commissioned ReliaTel™ controls
- Compressor lead-lag
- Crankcase heaters
- Emergency stop input
- Frostat™ coil frost protection on all units
- Occupied-Unoccupied switching
- Phase monitor
- Temperature discharge limit (TDL)
- Timed override activation
- FC supply fans
- Supply airflow proving
- Supply air overpressurization protection on VAV units
- Dedicated downflow, horizontal, or mixed airflow configurations
- Trane 3-D™ Scroll compressors
- Two inch standard efficiency filters
- Sloped condensate drain pan
- Cleanable, IAQ-enhancing, foil faced insulation on all interior surfaces exposed to the unit air stream
- cULus listing on standard options

## Optional Features

### Cabinet

- Factory installed condenser coil guards
- Factory installed tool-less condenser hail guards
- Hinged service access
- Downflow/upflow, horizontal, or mixed airflow configurations
- Sloped stainless steel evaporator coil drain pans

### Controls

- Statitrac™ direct space pressure control
- Trane Air Quality Traq™ (outside air measurement)
- BACnet Communication Interface (BCI-R)
- LonTalk® Communication Interface (LCI-R)
- Trane Communication Interface (TCI)
- Air-Fi™ Wireless Communications Interface (WCI)
- Touchscreen Human Interface
- CO<sub>2</sub> sensors for space comfort control (SCC) or discharge air control (DAC)
- Ventilation override



- Condensate Overflow Switch
- Remote potentiometer

## **Electrical**

- Factory mounted disconnect with external handle (non-fused)
- Factory powered or field powered 15A GFI convenience outlet
- High Fault SCCR
- Through-the-base electrical provision

## **Filtration**

- MERV 8 high efficiency 2" or 4" throwaway filters
- MERV 14 high efficiency 4" filters
- Clogged filter switch

## **Heat**

- Natural gas heat with single stage, two stage and modulating options
- Two stage LP gas heat (kit only)
- Stainless steel heat exchanger (gas heat only)
- Electric heat

## **Mechanical**

- CV, VAV, or SZ VAV Control
- Variable frequency drives on VAV and SZ VAV units (with or without bypass)
- Motors with Internal Shaft Grounding Ring
- Discharge air temperature sensor (CV only)
- 50% fresh air tracking power exhaust
- 100% fresh air tracking power exhaust
- 50% power exhaust
- 100% power exhaust
- Ultra low leak power exhaust
- Barometric relief
- Economizer with differential (comparative) enthalpy control
- Economizer with dry bulb control
- Economizer with reference enthalpy control
- Ultra low leak economizer with Fault Detection and Diagnostics (FDD)
- Manual fresh air damper

## **Refrigeration**

- High efficiency through eStage
- Corrosion protected condenser coil
- Modulating hot gas reheat
- Service valves



## Features and Benefits

---

### Quality and Reliability

#### Easy to Install, Service and Maintain

Because today's owners are very cost-conscious when it comes to service and maintenance, the Trane Voyager was designed with direct input from service contractors. This valuable information helped to design a product that would get the service technician off the job quicker and save the owner money.

#### Rigorous Testing

All of Voyager's designs were rigorously rain tested at the factory to ensure water integrity. Actual shipping tests are performed to determine packaging requirements. Units are test shipped around the country. Factory shake and drop tested as part of the package design process to help assure that the unit will arrive at your job site in top condition.

Rigging tests include lifting a unit into the air and letting it drop one foot, assuring that the lifting lugs and rails hold up under stress. 100% coil leak test is performed at the factory. The evaporator coil is pressure tested to 450 psig and the condenser coil at 650 psig.

All parts are inspected at the point of final assembly. Sub-standard parts are identified and rejected immediately. Every unit receives a 100% unit run test before leaving the production line to make sure it lives up to rigorous Trane requirements.

#### ReliaTel™ Controls

ReliaTel controls provide unit control for heating, cooling and ventilating utilizing input from sensors that measure outdoor and indoor temperature.

Quality and Reliability are enhanced through ReliaTel control and logic:

- Prevents the unit from short cycling, considerably improving compressor life.
- Ensures that the compressor will run for a specific amount of time which allows oil to return for better lubrication, enhancing the reliability of the commercial compressor.

Voyager with ReliaTel reduces the number of components required to operate the unit, thereby reducing possibilities for component failure.

#### ReliaTel Makes Installing and Servicing Easy

ReliaTel eliminates the need for field installed anti-shortcycle timer and time delay relays. ReliaTel controls provide these functions as an integral part of the unit. The contractor no longer has to purchase these controls as options and pay to install them.

The wiring of the low voltage connections to the unit and the zone sensors is as easy as 1-1, 2-2, and 3-3. This simplified system makes it easier for the installer to wire.

#### ReliaTel Makes Testing Easy

ReliaTel requires no special tools to run the Voyager unit through its paces. Simply place a jumper between Test 1 and Test 2 terminals on the Low Voltage Terminal Board and the unit will walk through its operational steps automatically.

**Note:** *The unit automatically returns control to the zone sensor after stepping through the test mode a single time, even if the jumper is left on the unit.*

As long as the unit has power and the "system on" LED is lit, ReliaTel is operational. The light indicates that the controls are functioning properly. ReliaTel features expanded diagnostic capabilities when utilized with Trane Integrated Comfort™ Systems. Some zone sensor options have central control panel lights which indicate the mode the unit is in and possible diagnostic information (dirty filters for example).

### Other ReliaTel Benefits

The ReliaTel's built-in anti-shortcycle timer, time delay relay and minimum "on" time control functions are factory tested to assure proper operation. ReliaTel softens electrical "spikes" by staging on fans, compressors and heaters. Intelligent Fallback is a benefit to the building occupant. If a component goes astray, the unit will continue to operate at predetermined temperature setpoint.

Intelligent Anticipation is a standard ReliaTel feature. It functions continuously as ReliaTel and zone sensor(s) work together in harmony to provide much tighter comfort control than conventional electro-mechanical thermostats.

### Human Interface

The 5 Inch Color Touchscreen Human Interface provides an intuitive user interface to the rooftop unit that speeds up unit commissioning, shortens unit troubleshooting times, and enhances preventative maintenance measures. The human interface includes several features such as:

- Data trending capabilities by means of time series graphs
- Historical alarm messages
- Real-time sensor measurements
- On board system setpoints
- USB port that enables the downloading of component runtime information as well as trended historical sensor data
- Customized reports

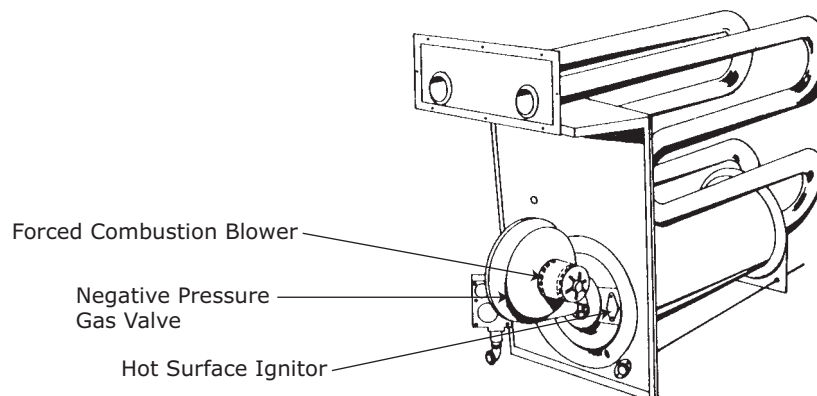


**Note:** For more information, refer to Tracer™ TD-5 literature, RT-SVX49\*-EN.

### Conversionless Units

The dedicated downflow, horizontal or mixed airflow configurations require no panel removal or alteration time to convert in the field — a major cost savings during installation.

### Drum and Tube Heat Exchanger (Gas Heat Only)



## Features and Benefits

---

The drum and tube heat exchanger is designed for increased efficiency and reliability and utilizes the same technology that has been incorporated into large commercial roof top units for over 20 years.

The heat exchanger is manufactured using optional stainless, or standard aluminized, steel with stainless steel components for maximum durability. The requirement for cycle testing of heat exchangers is 10,000 cycles by ANSI Z21.47. This is the standard required by both cULus and AGA for cycle test requirements. Trane requires the design to be tested to 2½ times this current standard. The drum and tube design has been tested and passed over 150,000 cycles which is over 15 times the current ANSI cycling requirements.

The regulated gas valve will not allow gas flow unless the combustion blower is operating. This is one of the unique safety features of Voyager Commercial. The forced combustion blower supplies pre-mixed fuel through a single stainless steel burner screen into a sealed drum where ignition takes place. It is more reliable to operate and maintain than a multiple burner system.

The hot surface ignitor is a gas ignition device which doubles as a safety device utilizing a continuous test to prove the flame. The design is cycle tested at the factory for quality and reliability.

All the gas/electric rooftops exceed all California seasonal efficiency requirements. They also perform better than required to meet the California NOx emission requirements.

## Low Ambient Cooling

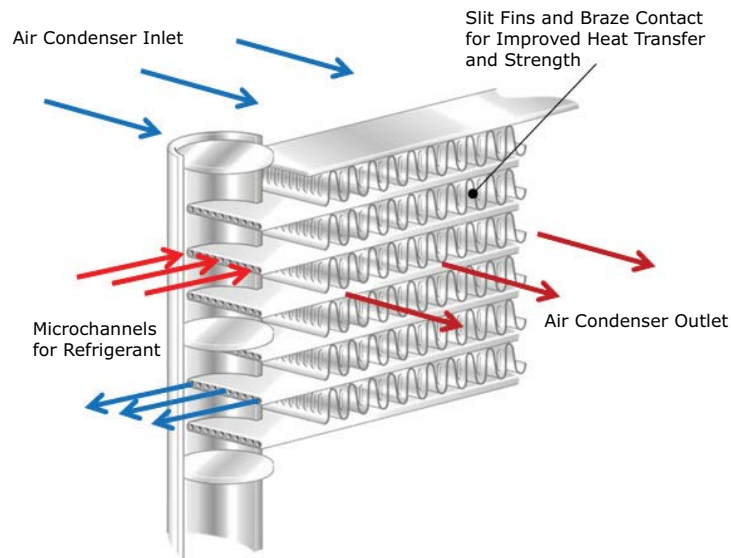
All Voyager Commercial units have cooling capabilities down to 0°F as standard.

## Microchannel Condenser Coils

Microchannel condensing coils are all-aluminum coils with fully-brazed construction. This design reduces risk of leaks and provides increased coil rigidity - making them more rugged on the jobsite. Their flat streamlined tubes with small ports and metallurgical tube-to-fin bond allow for exceptional heat transfer.

Microchannel all-aluminum construction provides several additional benefits:

- Light weight (simplifies coil handling)
- Easy to recycle
- Minimize galvanic corrosion



## Phase Monitor

Voyager features a three-phase line monitor module that protects against phase loss, phase reversal and phase unbalance. It is intended to protect compressors from reverse rotation. It has an operating input voltage range of 190–600 Vac, and LED indicators for ON and FAULT. There are no field adjustments and the module will automatically reset from a fault condition.

## Pressure Cutouts

Low and high pressure cutouts are standard on all models.

## Single Point Power

A single electrical connection powers the unit.

## Sloped Drain Pans

Every unit has a non-corrosive, sloped drain pan made of pre-painted steel and standard on all units.

## Temperature Discharge Limit (TDL)

A bi-metal element discharge line thermostats is installed as a standard feature on the discharge line of each system. This standard option provides extra protection to the compressors against high discharge temperatures in case of loss of charge, extremely high ambient and other conditions which could drive the discharge temperature higher.

## Outstanding Optional Features

### Variable Frequency Drives (VFD)

Variable Frequency Drives are factory installed and tested to provide supply fan motor speed modulation, as well as modulating gas heat. VFD's on the supply fan, as compared to inlet guide vanes or discharge dampers, are quieter, more efficient, and are eligible for utility rebates. The VFD's are available with or without a bypass option. Bypass control will simply provide full nominal airflow in the event of drive failure.

Modulating gas heat models with VFD's allow tighter space temperature control with less temperature swing.

### Single Zone VAV – An Ideal Energy Saving Solution for Yesterday's "Constant Volume" Systems

Single zone VAV is designed for use in single zone applications like gymnasiums, auditoriums, manufacturing facilities, retail box stores, and any large open spaces, where there is a lot of diversity in the load profile. Single Zone VAV (SZ VAV) is an ideal replacement to "yesterday's" constant volume (CV) systems, by reducing operating costs while improving occupant comfort.

SZ VAV systems combine Trane application, control and system integration knowledge to exactly match fan speed with cooling and heating loads, regardless of the operating condition. Trane algorithms meet/exceed ASHRAE 90.1- 2010, SZ VAV energy-saving recommendations, and those of CA Title 24. The result is an optimized balance between zone temperature control and system energy savings. Depending on your specific application, energy savings can be as much as 20+%.

**Note:** *Building system modeling in energy simulation software like TRACE is recommended to evaluate performance improvements for your application.*

SZ VAV is fully integrated into the ReliaTel Control system and is available today. It provides the simplest and fastest commissioning in the industry through proven factory-installed, wired, and tested system controllers. All control modules, logic and sensors are factory installed, and tested to assure the highest quality and most reliable system available. This means no special

## Features and Benefits

---

programming of algorithms, or hunting at the jobsite for sensors, boards, etc. that need to be installed in the field. Single zone VAV is a quick and simple solution for many applications and is available from your most trusted rooftop VAV system solution provider- Trane.

### Delivered VAV

Trane provides true pressure independent variable air volume with Voyager Commercial delivered VAV. The system is auto-configured to reduce programming and set-up time on the job. Generally available only on sophisticated larger models, this Voyager Commercial system can economically handle comfort requirements for any zone in the facility.

The system consists of:

- Voyager™ Commercial VAV packaged rooftops
- Up to 32 VariTrane™ VAV boxes with DDC (direct digital controls)
- VariTrac™ Central Control Panel (CCP) with Operator Display (OD)

The VariTrac Central Control Panel acts as a communications hub by coordinating the actions of the VAV rooftop and the VAV boxes. Single duct or fan powered VAV boxes are available, along with an option for factory-installed local heat. For more details, see VAV-SLM003-EN.

### VariTrac™ Changeover-Bypass VAV



For large commercial applications, Trane offers constant volume (CV) Voyager Commercial models with a changeover-bypass VAV system. For the most advanced comfort management systems, count on Trane.

### Power Exhaust Option



Provides exhaust of the return air when using an economizer to maintain proper building pressurization. Great for relieving most building overpressurization problems.

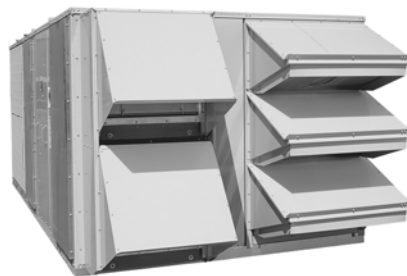
### Fresh Air Tracking Power Exhaust Option

Provides exhaust of the return air to maintain proper building pressurization by proportionally controlling the exhaust air to the economizer dampers; in other words, the exhaust damper "tracks" the outside air damper position.

### Statitrac™ Direct Space Building Pressurization Control

Trane's Statitrac™ control is a highly accurate and efficient method of maintaining building pressure control with a large rooftop air conditioner. Statitrac space pressure control turns the exhaust fans on and modulates exhaust dampers to maintain space pressure within the space pressure deadband. Proper building pressurization eliminates annoying door whistling, doors standing open, and odors from other zones.

### Downflow and Horizontal Economizers



The economizers come with three control options: dry bulb, enthalpy and differential enthalpy. The photo shows the three fresh air hoods on the horizontal discharge configuration.

### Trane Air Quality (Traq™) Outside Air Measurement System

Trane Air Quality (Traq) outside air measurement system uses velocity pressure sensing rings to measure airflow in the outside air opening from 40 cfm/ton to maximum airflow. Measurement accuracy is at least  $\pm 15\%$ , meeting requirements of LEED IE Q Credit 1.

### Interoperability with BACnet (BCI-R)

The Trane BACnet Control Interface (BCI-R) for Voyager Commercial offers a building automation control system with outstanding interoperability benefits. BACnet, which is an industry standard, is an open, secure and reliable network communication protocol for controls, created by American Society of Heating, refrigerating and Air-Conditioning Engineers, Inc. (ASHRAE).

Interoperability allows application or project engineers to specify the best products of a given type, rather than one individual supplier's entire system. It reduces product training and installation costs by standardizing communications across products. Interoperable systems allow building managers to monitor and control IntelliPak equipment with Tracer SC controls or a 3<sup>rd</sup> party building automation system. It enables integration with many different building controls such as access/intrusion monitoring, lighting, fire and smoke devices, energy management, and a wide variety of sensors (temperature, pressure, light, humidity, occupancy, CO<sub>2</sub> and air velocity).

### Interoperability with LonTalk® (LCI-R)

The LonTalk Communication (LCI-R) for Voyager Commercial offers a building automation control system with outstanding interoperability benefits. LonTalk, which is an industry standard, is an open, secure and reliable network communication protocol for controls, created by Echelon Corporation and adopted by the LonMark Interoperability Association. It has been adopted by several standards, such as: EIA-709.1, the Electronic Industries Alliance (EIA) Control Network Protocol Specification and ANSI/ASHRAE 135, part of the American Society of Heating, Refrigeration, and Air-Conditioning Engineer's BACnet control standard for buildings.

Interoperability allows application or project engineers to specify the best products of a given type, rather than one individual supplier's entire system. It reduces product training and installation costs by standardizing communications across products.

Interoperable systems allow building managers to monitor and control Voyager Commercial equipment with a Trane Tracer Summit™ or a 3<sup>rd</sup> party building automation system.

## Features and Benefits

It enables integration with many different building controls such as access/intrusion monitoring, lighting, fire and smoke devices, energy management, and a wide variety of sensors for temperature, pressure, humidity and occupancy CO<sub>2</sub>. For additional information visit LonMark, [www.lonmark.org](http://www.lonmark.org) or Echelon, [www.echelon.com](http://www.echelon.com).

### Trane Communication Interface (TCI)

The TCI is available factory or field installed. When applied with ReliaTel, this module easily interfaces with the Trane Integrated Comfort™ System.

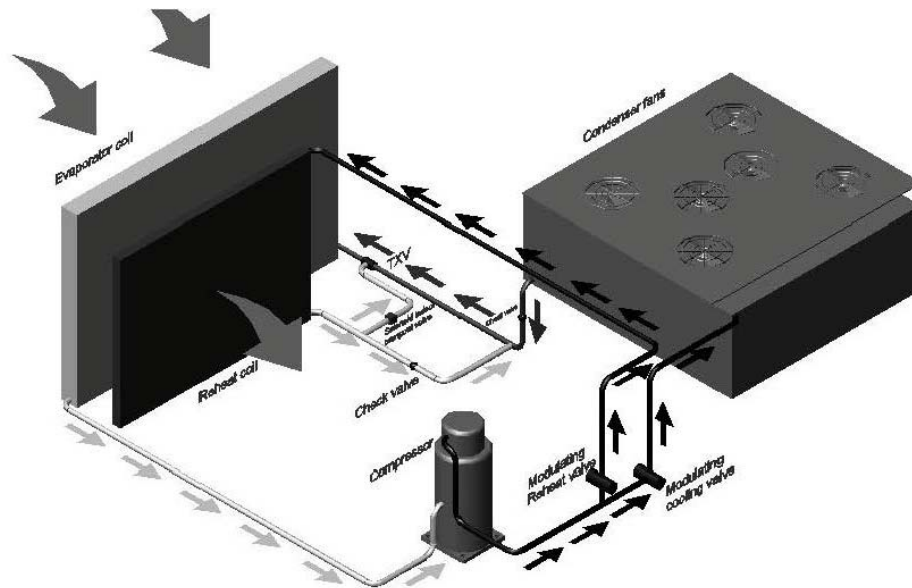
### Trane Air-Fi™ Wireless Comm Interface (WCI)

The Trane® Air-Fi Wireless Comm Interface (WCI) is the perfect alternative to Trane's BACnet™ wired communication links (for example, Trane® Air-Fi Wireless Communications Interface between a Tracer® SC and a Tracer UC400). Minimizing communication wire use between terminal products, zone sensors, and system controllers has substantial benefits. Installation time and associated risks are reduced. Projects are completed with fewer disruptions. Future re-configurations, expansions, and upgrades are easier and more cost effective.

### Modulating Hot Gas Reheat

This option allows for increased outdoor air ventilation. It reduces humidity levels while increasing comfort level in the air space. Cooling can operate without a demand for dehumidification. The hot gas reheat coil and modulating valve are designed to deliver maximum reheat temperatures and increase unit efficiency. This energy efficiency helps to meet local energy codes and ASHRAE Standard 90.1 compliance.

**Figure 1. Modulating hot gas reheat option**



### Tool-Less Condenser Hail Guards

Tool-less condenser hail guards are available as a factory installed option to protect the unit condenser coil from hail, debris damage and vandalism.

### Trane Factory Built Roof Curbs

Available for all units.



### Motor Shaft Grounding Ring

Motors with internal Shaft grounding rings can be used with VFDs to provide a conductive discharge path away from the motor bearings to ground.

### Stainless Steel Sloped Drain Pans

The non-porous, stainless steel surface on these drain pans avoids the harboring of dirt and bacteria, while discouraging microbial growth and helping to promote indoor air quality. The material is easy to clean, long lasting, and extremely durable, thus minimizing drain pan deterioration and premature leakage. The stainless steel drain pans are sloped, allowing for easy and fast water exit.

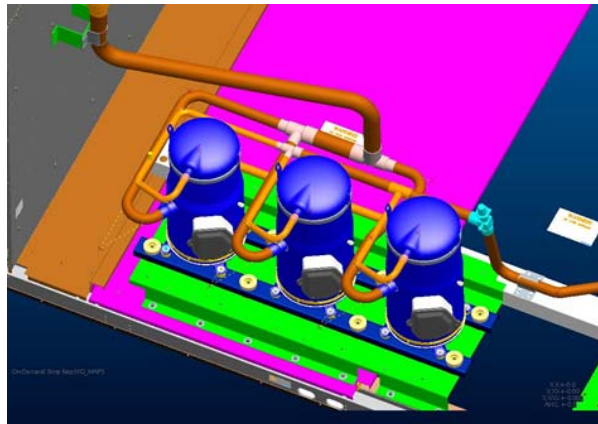
### Condensate Overflow Switch

A condensate overflow switch is available to shut the unit down in the event that the condensate drain becomes clogged. This option protects the unit from water overflowing from the drain pan and entering the base of the unit.

### eStage - High Efficiency Units

Through compressor staging on a single circuit, this option allows units to have a maximum 25% load at the first stage allowing the unit to meet Title 24, along with providing increased full load and part load unit efficiency.

**Figure 2. eStage configuration**



## One of Our Finest Assets

Trane Commercial Sales Engineers are a support group that can assist you with:

- Product
- Application
- Service
- Training
- Special Applications
- Specifications
- Computer Programs and more



# Application Considerations

## 60/50 Hz Units

### Exhaust Air Options

When is it necessary to provide building exhaust?

Whenever an outdoor air economizer is used, a building generally requires an exhaust system. The purpose of the exhaust system is to exhaust the proper amount of air to prevent over or under-pressurization of the building.

A building may have all or part of its exhaust system in the rooftop unit. Often, a building provides exhaust external to the air conditioning equipment. This external exhaust must be considered when selecting the rooftop exhaust system.

Voyager™ Commercial rooftop units offer four types of exhaust systems:

1. 50% or 100% Power exhaust fan
2. 50% or 100% Fresh Air Tracking Power Exhaust Fan(s)
3. 100% Power Exhaust with Statitrac™ Building Pressure Control
4. Barometric relief dampers

### Application Recommendations

#### Power Exhaust Fan (with or without Fresh Air Tracking)

The exhaust fan option is either a single fan for exhausting approximately half of the air-moving capabilities of the supply fan system or dual fans for 100% exhaust. Either exhaust capability arrangement is configured as an on/off non-modulating exhaust or an on/off exhaust with an actuator controlled damper to track the position of the fresh air damper.

For non-100% air applications, the 50% non-tracking power exhaust fan generally should not be selected for more than 40 to 50% of design supply airflow. Since it is an on/off non-modulating fan, it does not vary exhaust cfm with the amount of outside air entering the building. Therefore, if selected for more than 40 to 50% of supply airflow, the building may become under pressurized when economizer operation is allowing lesser amounts of outdoor air into the building. If, however, building pressure is not of a critical nature, the non-modulating exhaust fan may be sized for more than 50% of design supply airflow. Consult [Table 26, p. 60](#) and [Table 27, p. 60](#) (60Hz) or [Table 54, p. 84](#) and [Table 55, p. 85](#) (50Hz) for specific exhaust fan capabilities with Voyager Commercial units.

#### 100% Power Exhaust with Statitrac™ Building Pressure Control

This control is available only with 100% power exhaust. The exhaust dampers are modulated in response to building pressure. Statitrac, a differential pressure control system, uses a differential pressure transducer to compare indoor building pressure to atmospheric pressure. The exhaust fans are turned on when required to lower building static pressure to setpoint. The Statitrac control system then modulates the exhaust dampers to control the building pressure to within the adjustable, specified deadband that is set at the RTVM board. Economizer and return air dampers are modulated independent of the exhaust dampers based on ventilation control and economizer cooling requests.

Statitrac can only lower building pressure; it cannot raise it. To lower building pressure, Statitrac exhausts air from the space using the power exhaust. To raise building pressure, more air must be supplied to the space, as with economizer operation. Additional relief, such as a bathroom exhaust fan or relief fan, as well as other units serving the space, will affect building pressure and must be taken into account.

#### Barometric Relief Dampers

Barometric relief dampers consist of gravity dampers which open with increased building pressure. As the building pressure increases, the pressure in the unit return section also increases,

opening the dampers and relieving air. Barometric relief may be used to provide relief for single story buildings with no return ductwork and exhaust requirements less than 25%.

## Altitude Corrections

The rooftop performance tables and curves of this catalog are based on standard air (.075 lbs/ft). If the rooftop airflow requirements are at other than standard conditions (sea level), an air density correction is needed to project accurate unit performance.

Figure 4, p. 45 shows the air density ratio at various temperatures and elevations. Trane rooftops are designed to operate between 40° and 90°F leaving air temperature.

The procedure to use when selecting a supply or exhaust fan on a rooftop for elevations and temperatures other than standard is as follows:

1. First, determine the air density ratio using Figure 4, p. 45.
2. Divide the static pressure at the nonstandard condition by the air density ratio to obtain the corrected static pressure.
3. Use the actual cfm and the corrected static pressure to determine the fan rpm and bhp from the rooftop performance tables or curves.
4. The fan rpm is correct as selected.
5. Bhp must be multiplied by the air density ratio to obtain the actual operating bhp.

In order to better illustrate this procedure, the following examples are used:

### 60 Hz

Consider a 30 ton rooftop unit that is to deliver 11,000 actual cfm at 1.50 inches total static pressure (tsp), 55°F leaving air temperature, at an elevation of 5,000 ft.

1. From Figure 4, p. 45, the air density ratio is 0.86.
2.  $Tsp = 1.50 \text{ inches} / 0.86 = 1.74 \text{ inches tsp}$ .
3. From the performance tables: a 30 ton rooftop will deliver 11,000 cfm at 1.74 inches tsp at 632 rpm and 6.2 bhp.
4. The rpm is correct as selected — 632 rpm.
5.  $Bhp = 6.2 \times 0.86 = 5.33$ .

Compressor MBh, SHR, and kW should be calculated at standard and then converted to actual using the correction factors in Table 9, p. 45. Apply these factors to the capacities selected at standard cfm so as to correct for the reduced mass flow rate across the condenser.

Heat selections other than gas heat will not be affected by altitude. Nominal gas capacity (output) should be multiplied by the factors given in Table 10, p. 45 before calculating the heating supply air temperature.

### 50 Hz

Consider a 29 ton (105 kW) rooftop unit that is to deliver 9,160 actual cfm (4323 L/s) at 1.50 inches total static pressure (tsp) (38 mm, 373 Pa), 55°F (12.8°C) leaving air temperature, at an elevation of 5,000 ft (1524 m).

1. From Figure 4, p. 45, the air density ratio is 0.86.
2.  $Tsp = 1.50 \text{ inches} / 0.86 = 1.74 \text{ inches tsp}$ .  $374 / .86 = 434 \text{ Pa}$ .
3. From the performance tables: a 29-ton (105 kW) rooftop will deliver 9,160 cfm at 1.74 inches tsp (4323 L/s at 434 Pa) at 618 rpm and 4.96 bhp (3.7 kW).
4. The rpm is correct as selected – 618 rpm.
5.  $Bhp = 4.96 \times 0.86 = 4.27 \text{ bhp actual}$ .  $kW = 3.7 \times 0.86 = 3.18 \text{ kW}$

## Application Considerations

---

Compressor MBh, SHR, and kW should be calculated at standard and then converted to actual using the correction factors in [Table 9, p. 45](#). Apply these factors to the capacities selected at standard cfm so as to correct for the reduced mass flow rate across the condenser.

Heat selections other than gas heat will not be affected by altitude. Nominal gas capacity (output) should be multiplied by the factors given in [Table 10, p. 45](#) before calculating the heating supply air temperature.

## Acoustical Considerations

Proper placement of rooftops is critical to reducing transmitted sound levels to the building. The ideal time to make provisions to reduce sound transmissions is during the design phase. The most economical means of avoiding an acoustical problem is to place the rooftop(s) away from acoustically critical areas. If possible, rooftops should not be located directly above areas such as: offices, conference rooms, executive office areas and classrooms. Instead, ideal locations might be over corridors, utility rooms, toilets or other areas where higher sound levels directly below the unit(s) are acceptable.

Several basic guidelines for unit placement should be followed to minimize sound transmission through the building structure:

1. Never cantilever the compressor end of the unit. A structural cross member must support this end of the unit.
2. Locate the unit center of gravity which is close to, or over, a column or main support beam.
3. If the roof structure is very light, roof joists must be replaced by a structural shape in the critical areas described above.
4. If several units are to be placed on one span, they should be staggered to reduce deflection over that span.

It is impossible to totally quantify the effect of building structure on sound transmission, since this depends on the response of the roof and building members to the sound and vibration of the unit components. However, the guidelines listed above are experience- proven guidelines which will help reduce sound transmissions.

## Clearance Requirements

The recommended clearances identified with unit dimensions should be maintained to assure adequate serviceability, maximum capacity and peak operating efficiency. A reduction in unit clearance could result in condenser coil starvation or warm condenser air recirculation. If the clearances shown are not possible on a particular job, consider the following:

Do the clearances available allow for major service work such as changing compressors or coils?

Do the clearances available allow for proper outside air intake, exhaust air removal and condenser airflow?

If screening around the unit is being used, is there a possibility of air recirculation from the exhaust to the outside air intake or from condenser exhaust to condenser intake?

Actual clearances which appear inadequate should be reviewed with a local Trane sales engineer.

When two or more units are to be placed side by side, the distance between the units should be increased to 150% of the recommended single unit clearance. The units should also be staggered for two reasons:

1. To reduce span deflection if more than one unit is placed on a single span. Reducing deflection discourages sound transmission.
2. To assure proper diffusion of exhaust air before contact with the outside air intake of adjacent unit.

### Duct Design

It is important to note that the rated capacities of the rooftop can be met only if the rooftop is properly installed in the field. A well designed duct system is essential in meeting these capacities.

The satisfactory distribution of air throughout the system requires that there be an unrestricted and uniform airflow from the rooftop discharge duct. This discharge section should be straight for at least several duct diameters to allow the conversion of fan energy from velocity pressure to static pressure.

When job conditions dictate elbows be installed near the rooftop outlet, the loss of capacity and static pressure may be reduced through proper direction of the bend in the elbow. The high velocity side of the rooftop outlet should be directed at the outside radius of the elbow rather than the inside.



# Selection Procedure

## 60 Hz Units

### Five Basic Areas

- Cooling capacity
- Heating capacity
- Air delivery
- Unit electrical requirements
- Unit designation

### Cooling Capacity Selection

- Summer design conditions — 95 DB/76 WB, 95°F entering air to condenser.
- Summer room design conditions — 76 DB/66 WB.
- Total peak cooling load — 321 MBh (26.75 tons).
- Total peak supply cfm — 12000 cfm.
- External static pressure — 1.2 inches.
- Return air temperatures — 80 DB/66 WB.
- Return air cfm — 10800 cfm.
- Outside air ventilation cfm and load — 1200 cfm and 18.23 MBh (1.52 tons).
- Unit accessories include:
  - Aluminized heat exchanger — high heat module.
  - 2" hi-efficiency throwaway filters.
  - Economizer.

#### Step 1

A summation of the peak cooling load and the outside air ventilation load shows: 26.75 tons + 1.52 tons = 28.27 required unit capacity. From [Table 13, p. 48](#), 30-ton unit capacity at 80 DB/67 WB, 95°F entering the condenser and 12,000 total peak supply cfm, is 353 MBh (29.4 tons). Thus, a nominal 30 ton unit is selected.

#### Step 2

Having selected a nominal 30 ton unit, the supply fan and exhaust fan motor bhp must be determined.

#### Supply Air Fan

Determine unit static pressure at design supply cfm (see [Table 24, p. 58](#)):

External static pressure = 1.20 inches

Heat exchanger = High Heat: 0.14 inches

High efficiency filter 2" = 0.23 inches

Indoor coil = 0.34 inches

Economizer = 0.07 inches

Unit total static pressure = 1.98 inches

Using total cfm of 12000 and total static pressure of 1.98 inches, [Figure 5, p. 57](#) shows 7.78 bhp with 676 rpm.

### Step 3

Determine evaporator coil entering air conditions. Mixed air dry bulb temperature determination.

Using the minimum percent of OA (1,200 cfm ÷ 12,000 cfm = 10 percent), determine the mixture dry bulb to the evaporator.  $RADB + \%OA (OADB - RADB) = 80 + (0.10) (95 - 80) = 80 + 1.5 = 81.5^{\circ}F$

#### Approximate Wet Bulb Mixture Temperature

$RAWB + OA (OAWB - RAWB) = 66 + (0.10) (76-66) = 68 + 1 = 67^{\circ}F$ . A psychrometric chart can be used to more accurately determine the mixture temperature to the evaporator coil.

### Step 4

#### Determine Total Required Unit Cooling Capacity

Required capacity = total peak load + O.A. load + supply air fan motor heat. From [Figure 3, p. 25](#), the supply air fan motor heat for 7.78 bhp = 22.1 MBh. Capacity = 321 + 18.23 + 22.1 = 361.3 MBh (30.1 tons)

### Step 5

#### Determine Unit Capacity

From [Table 13, p. 48](#) unit capacity at 81.5 DB, 67 WB entering the evaporator, 12000 supply air cfm, 95°F entering the condenser is 355 MBh (29.6 tons) 290 sensible MBh.

### Step 6

#### Determine Leaving Air Temperature

Unit sensible heat capacity, corrected for supply air fan motor heat  $290 - 22.1 = 267.9$  MBh.

Supply air dry bulb temperature difference =  $267.9 \text{ MBh} \div (1.085 \times 12,000 \text{ cfm}) = 20.6^{\circ}F$ .

Supply air dry bulb:  $81.5 - 20.6 = 60.9$ .

Unit enthalpy difference =  $355 \div (4.5 \times 12,000) = 6.57$  Btu/lb.

Btu/lb leaving enthalpy = h (ent WB) = 31.62 Btu/lb.

Leaving enthalpy = 31.62 Btu/lb - 6.57 Btu/lb = 25.1 Btu/lb.

From [Table 8, p. 44](#), the leaving air wet bulb temperature corresponding to an enthalpy of 25.1 Btu/lb = 58°F.

Leaving air temperatures = 60.9°F/58°F

## Heating Capacity Selection

- Winter outdoor design conditions—0°F.
- Total return air temperature — 72°F.
- Winter outside air minimum ventilation load and cfm — 1,200 cfm and 87.2 MBh.
- Peak heating load 225 MBh.

#### Utilizing Unit selection in the Cooling Capacity Procedure

Mixed air temperature =  $RADB + \%O.A. (OADB - RADB) = 72 + (0.10) (0-72) = 64.8^{\circ}F$ .

Supply air fan motor heat temperature rise =  $20,600 \text{ BTU} \div (1.085 \times 12,000) \text{ cfm} = 1.6^{\circ}F$ .

Mixed air temperature entering heat module =  $64.8 + 1.6 = 66.4^{\circ}F$ .

Total winter heating load = peak heating + ventilation load - total fan motor heat =  $225 + 87.2 - 22.1 = 290.1$  MBh.

## Selection Procedure

---

### Electric Heating System

Unit operating on 480/60/3 power supply. From [Table 22, p. 56](#), 90 kw may be selected for a nominal 30-ton unit operating on 480-volt power. The high heat module — 90 KW or 307 MBh will satisfy the winter heating load of 290.1 MBh.

[Table 21, p. 56](#) shows an air temperature rise of 23.6°F for 12,000 cfm through the 90 kw heat module.

Unit supply temperature at design heating conditions = mixed air temperature + air temperature rise = 66.4 + 23.6 = 90°F.

### Natural Gas Heating System

Assume natural gas supply — 1000 Btu/ft<sup>3</sup>. From [Table 23, p. 56](#) select the high heat module (480 MBh output) to satisfy 290.1 at unit cfm.

[Table 23, p. 56](#) also shows air temperature rise of 36.9°F for 12,000 cfm through heating module.

Unit supply temperature design heating conditions = mixed air temperature + air temperature rise = 66.4 + 36.9 = 103.3°F.

### Hot Gas Reheat Dehumidification Selection

The hot gas reheat option allows for increased outdoor air ventilation. It reduces humidity levels while increasing comfort level in the air space.

**Note:** Please note that hot gas reheat operation will not be allowed when there is a call for cooling or heating.

Utilize the Trane TOPSS™ selection program or contact a local Trane sales office to calculate leaving unit air temperature, latent capacity, reheat sensible capacity, leaving unit dew point, and moisture removal when the unit is in hot gas reheat operation.

The hot gas reheat TOPSS selection requires the following customer input values: supply fan airflow, ambient air temperatures, entering air temperatures, and a desired reheat set point temperature. If the conditions provided are not within the reheat operating envelope an error will be generated in the TOPSS program. If the reheat set point is not obtainable at the provided conditions the customer will be required to make adjustments to the conditions or change the reheat set point value.

## Air Delivery Procedure

Supply air fan bhp and rpm selection. Unit supply air fan performance shown in [Figure 5, p. 57](#) includes pressure drops for dampers and casing losses. Static pressure drops of accessory components such as heating systems, and filters if used, must be added to external unit static pressure for total static pressure determination.

The supply air fan motor selected in the previous cooling capacity determination example was 7.78 bhp with 676 rpm. Thus, the supply fan motor selected is 7.5 hp.

To select the drive, enter [Table 25, p. 59](#) for a 30-ton unit. Select the appropriate drive for the applicable rpm range. Drive selection letter C with a range of 650 rpm, is required for 676 rpm. Where altitude is significantly above sea level, use [Table 9, p. 45](#), [Table 10, p. 45](#) and [Figure 4, p. 45](#) for applicable correction factors.

## Unit Electrical Requirements

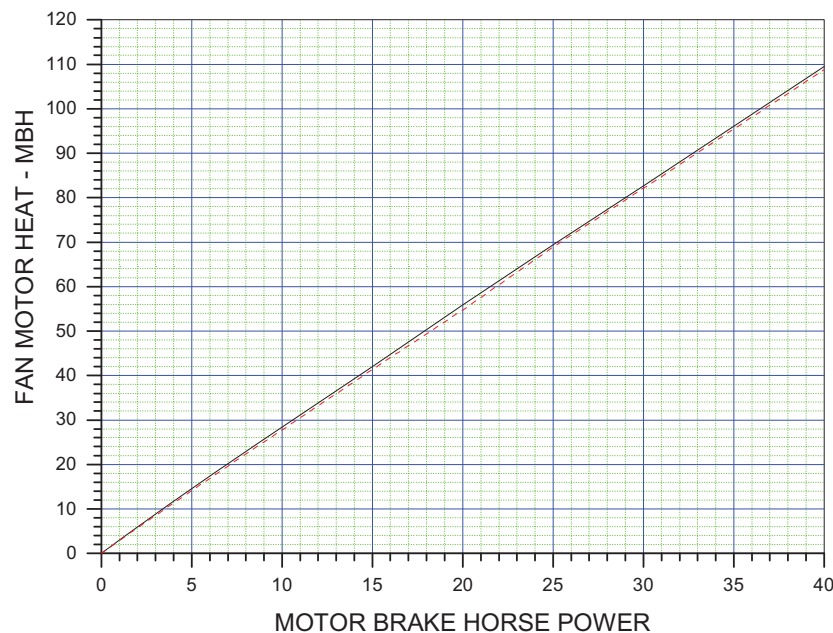
Selection procedures for electrical requirements for wire sizing amps, maximum fuse sizing and dual element fuses are given in the electrical service selection of this catalog.



### Unit Designation

After determining specific unit characteristics utilizing the selection procedure and additional job information, the complete unit model number can be developed using the model number nomenclature page.

**Figure 3. Fan motor heat**



### 50 Hz Units

#### Five basic areas

- Cooling capacity
- Heating capacity
- Air delivery
- Unit electrical requirements
- Unit designation

#### Cooling Capacity Selection

- Summer design conditions – 95 DB/76 WB (35/24.4°C), 95°F (35°C) entering air to condenser.
- Summer room design conditions – 76 DB/66 WB (24.4/18.9°C).
- Total peak cooling load – 270 MBh (79 kW) (22.5 tons).
- Total peak supply cfm – 10,000 cfm (4720 L/s).
- External static pressure – 1.24 inches wc (310 Pa).
- Return air temperatures – 80 DB/66°F WB (26.7/18.9°C).
- Return air cfm – 3540 cfm (1671 L/s).
- Outside air ventilation cfm and load – 1000 cfm and 15.19 MBh (1.27 tons or 4.45 kW) 472 L/s.
- Unit accessories include:
  - Aluminized heat exchanger – high heat module.

## Selection Procedure

---

- 2" Hi-efficiency throwaway filters.
- Exhaust fan.
- Economizer cycle.

### Step 1

A summation of the peak cooling load and the outside air ventilation load shows: 22.5 tons + 1.27 tons = 23.77 (79 kW + 4.45 kW = 83.45) required unit capacity. From [Table 32, p. 65](#), 25.4 ton (89 kW) unit capacity at 80 DB/67 WB (27/19°C), 95°F entering the condenser and 10,000 total peak supply cfm (4720 L/s) is 297 MBh (24.75 tons).

### Step 2 - Supply Air Fan

Having selected the correct unit, the supply fan and exhaust fan motor bhp must be determined.

Using [Table 52, p. 83](#), determine unit static pressure at design supply cfm:

External static pressure = 1.24 inches (310 Pa)

Heat exchanger = 0.12 inches (30 Pa)

High efficiency filter 2" (50 mm) = 0.18 inches (45 Pa)

Economizer = 0.07 inches (17 Pa)

Unit total static pressure = 1.61 inches (402 Pa)

Using total cfm of 10,000 (4720 L/s) and total static pressure of 1.61 inches (41 mm), refer to [Figure 7, p. 82](#). [Figure 7](#) shows 5.11 bhp (3.8 kW) with 601 rpm.

### Step 3 - Determine Evaporator Coil Entering Air Conditions

Mixed air dry bulb temperature determination:

Using the minimum percent of OA (1,000 cfm ÷ 10,000 cfm = 10 percent), determine the mixture dry bulb to the evaporator.  $RADB + \% OA (OADB - RADB) = 80 + (0.10) (95 - 80) = 80 + 1.5 = 81.5^\circ\text{F}$  ( $26.7 + 1.5 = 28^\circ\text{C}$ ).

Approximate Wet Bulb Mixture Temperature:

$RAWB + OA (OAWB - RAWB) = 66 + (0.10) (76-66) = 68 + 1 = 67^\circ\text{F}$

A psychrometric chart can be used to more accurately determine the mixture temperature to the evaporator coil.

### Step 4 - Determine Total Required Unit Cooling Capacity

Required capacity = total peak load + O.A. load + supply air fan motor heat. From [Figure 3, p. 25](#), the supply air fan motor heat for 5.11 bhp = 14 MBh. Capacity = 270 + 15 + 14 = 299 MBh (89 kW)

### Step 5 - Determine Unit Capacity

From [Table 32, p. 65](#) unit capacity at 81.5 DB/67 WB entering the evaporator, 10,000 supply air cfm, 95°F (35°C) entering the condenser about 298 MBh (87 kW) with 243 MBh (71.1 kW) sensible.

### Step 6 - Determine Leaving Air Temperature

Unit sensible heat capacity, corrected for supply air fan motor heat 243 - 14 = 229 MBh (67 kW).

Supply air dry bulb temperature difference = 229 MBh ÷ (1.085 x 10,000 cfm) = 21.1°F (-6.1°C)

Supply air dry bulb: 81.5-21.1 = 60.4 (15.8°C)

Unit enthalpy difference = 298 ÷ (4.5 x 10,000) = 6.62

Btu/lb leaving enthalpy = h (ent WB) = 31.62

Leaving enthalpy = 31.62 Btu/lb - 6.62 Btu/lb = 25 Btu/lb.

From [Table 8, p. 44](#), the leaving air wet bulb temperature corresponding to an enthalpy of 25 Btu/lb = 57.8°F (14.3°C).

Leaving air temperatures = 60.4 DB/57.8 WB (15.8/14.3°C).

## Heating Capacity Selection

- Winter outdoor design conditions – 0°F (-17.8°C).
- Total return air temperature – 72°F (22.2°C).
- Winter outside air minimum ventilation load and cfm – 1,000 cfm and 87.2 MBh.
- Peak heating load 150 MBh.

Utilizing unit selection in the cooling capacity procedure.

Mixed air temperature = RADB + % O.A. (OADB - RADB) = 72 + (0.10) (0-72) = 64.8°F

Supply air fan motor heat temperature rise = 20,600 Btu ÷ (1.085 × 10,000) cfm = 1.9°F

Mixed air temperature entering heat module = 64.8 + 1.9 = 66.7°F

Total winter heating load = peak heating + ventilation load - total fan motor heat = 150 + 87.2 - 14 = 223.2 MBh.

## Electric Heating System

Unit operating on 415 power supply. From [Table 48, p. 81](#), kW may be selected for TC\*305 unit to satisfy the winter heating load. The 67 kW module will do the job.

[Table 48, p. 81](#) also shows an air temperature rise of 21.2°F for 10,000 cfm through the 67 kW heat module.

Unit supply temperature at design heating conditions = mixed air temperature + air temperature rise = 66.7 + 21.2 = 87.9°F

## Natural Gas Heating System

Assume natural gas supply – 1000 Btu/ft<sup>3</sup>. From [Table 51, p. 81](#), select the low heat module (232 MBh output) to satisfy 223 at unit cfm.

[Table 51, p. 81](#) also shows air temperature rise of 21.4°F for 10,000 cfm through heating module.

Unit supply temperature design heating conditions = mixed air temperature + air temperature rise = 66.7 + 21.4 = 88.1°F

## Hot Gas Reheat Dehumidification Selection

The hot gas reheat option allows for increased outdoor air ventilation. It reduces humidity levels while increasing comfort level in the air space.

**Note:** Please note that hot gas reheat operation will not be allowed when there is a call for cooling or heating.

Use the Trane TOPSS™ selection program or contact a local Trane sales office to calculate leaving unit air temperature, latent capacity, reheat sensible capacity, leaving unit dew point, and moisture removal when the unit is in hot gas reheat operation.

The hot gas reheat TOPSS selection requires the following customer input values: supply fan airflow, ambient air temperatures, entering air temperatures, and a desired reheat set point temperature. If the conditions provided are not within the reheat operating envelope an error will be generated in the TOPSS program. If the reheat set point is not obtainable at the provided conditions the customer will be required to make adjustments to the conditions or change the reheat set point value.

## Air Delivery Procedure

Supply air fan bhp and rpm selection. Unit supply air fan performance shown in [Figure 7, p. 82](#) and [Figure 8, p. 82](#) includes pressure drops for dampers and casing losses. Static pressure drops of accessory components such as heating systems, and filters if used, must be added to external unit static pressure for total static pressure determination.



## Selection Procedure

---

The supply air fan motor selected in the previous cooling capacity determination example was 5.11 bhp with 601 rpm. Thus, the supply fan motor selected is 7.5 hp.

To select the drive, enter [Table 53, p. 84](#) for a 25.4 unit. Select the appropriate drive for the applicable rpm range. Drive selection letter D with a range of 583 rpm, is required for 601 rpm. Where altitude is significantly above sea level, use [Table 9, p. 45](#), [Table 10, p. 45](#) and [Figure 4, p. 45](#) for applicable correction factors.

## Unit Electrical Requirements

Selection procedures for electrical requirements for wire sizing amps, maximum fuse sizing and dual element fuses are given in the electrical service selection of this catalog.

## Unit Designation

After determining specific unit characteristics utilizing the selection procedure and additional job information, the complete unit model number can be developed using the model number nomenclature page.

# Model Number Descriptions

Y	C	D	3	3	0	B	E	L	A	O	A	1
1	2	3	4	5	6	7	8	9	10	11	12	13

## 60 Hz Description

### Digit 1, 2 – Unit Function

- TC = DX Cooling, No Heat
- TE = DX Cooling, Electric Heat
- YC = DX Cooling, Natural Gas Heat

### Digit 3 – Unit Airflow Design

- D = Downflow Supply and Upflow Return
- H = Horizontal Supply and Horizontal Return
- F = Horizontal Supply and Upflow Return
- R = Downflow Supply and Horizontal Return

### Digit 4, 5, 6 – Nominal Cooling Capacity

- 330 = 27½ Tons
- 360 = 30 Tons
- 420 = 35 Tons
- 480 = 40 Tons
- 600 = 50 Tons

### Digit 7 – Major Development Sequence

- B = R-410A Refrigerant

### Digit 8 – Power Supply<sup>1</sup>

- E = 208/60/3
- F = 230/60/3
- 4 = 460/60/3
- 5 = 575/60/3

### Digit 9 – Heating Capacity<sup>3</sup>

- 0 = No Heat (TC Only)
- L = Low Heat (YC Only)
- H = High Heat (YC Only)
- J = Low Heat-Stainless Steel Gas Heat Exchanger (YC Only)
- K = High Heat-Stainless Steel Gas Heat Exchangers (YC Only)
- M = Low Heat-Stainless Steel Gas Heat Exchanger w/ Modulating Control (27.5-35 Tons YC only)
- P = High Heat-Stainless Steel Gas Heat Exchangers w/ Modulating Control (27.5-35 Tons YC Only)
- R = Low Heat-Stainless Steel Gas Heat Exchanger w/ Modulating Control (40-50 Tons YC Only)
- T = High Heat-Stainless Steel Gas Heat Exchangers w/ Modulating Control (40-50 Tons YC Only)

**Note:** When second digit is “E” for Electric Heat, the following values apply in the ninth digit.

- A = 36 kW (27 kW for 208v)
- B = 54 kW (41 kW for 208v)
- C = 72 kW
- D = 90 kW
- E = 108 kW

### Digit 10 – Design Sequence

- A = First

### Digit 11 – Exhaust<sup>5</sup>

- 0 = None
- 1 = Barometric Relief (Available w/ Economizer only)
- 2 = 100% Power Exhaust Fan (Available w/ Economizer Only)
- 3 = 50% Power Exhaust Fan (Available w/ Economizer Only)
- 4 = 100% Fresh Air Tracking Power Exhaust Fan (Available w/ Economizer Only)
- 5 = 50% Fresh Air Tracking Power Exhaust Fan (Available w/ Economizer Only)
- 6 = 100% Power Exhaust w/ Statitrac™
- 7 = 100% Power Exhaust Fan w/ Ultra Low Leak Exhaust Damper (Available w/ Economizer Only)
- 8 = 50% Power Exhaust Fan w/ Ultra Low Leak Exhaust Damper (Available w/ Economizer Only)
- 9 = 100% Power Exhaust w/ Ultra Low Leak Exhaust Damper w/ Statitrac™

### Digit 12 – Filter

- A = 2” MERV 4, Std Eff, Throwaway Filters
- B = 2” MERV 8, High Eff, Throwaway Filters
- C = 4” MERV 8, High Eff, Throwaway Filters
- D = 4” MERV 14, High Eff, Throwaway Filters

### Digit 13 – Supply Fan Motor, HP

- 1 = 7.5 Hp
- 2 = 10 Hp
- 3 = 15 Hp
- 4 = 20 Hp

### Digit 14 – Supply Air Fan Drive Selections

- A = 550 RPM
- B = 600 RPM
- C = 650 RPM
- D = 700 RPM
- E = 750 RPM
- F = 790 RPM
- G = 800 RPM
- H = 500 RPM
- J = 525 RPM
- K = 575 RPM
- L = 625 RPM
- M = 675 RPM
- N = 725 RPM

### Digit 15 – Fresh Air Selection

- A = No Fresh Air
- B = 0-25% Manual Damper
- C = 0-100% Economizer, Dry Bulb Control
- D = 0-100% Economizer, Reference Enthalpy Control
- E = 0-100% Economizer, Differential Enthalpy Control
- F = “C” Option and Low Leak Fresh Air Damper
- G = “D” Option and Low Leak Fresh Air Damper
- H = “E” Option and Low Leak Fresh Air Damper
- J = “C” Option and Ultra Low Leak Outside Air Damper
- K = “D” Option and Ultra Low Leak Outside Air Damper
- L = “E” Option and Ultra Low Leak Outside Air Damper
- 1 = Option “C” with Traq
- 2 = Option “D” with Traq
- 3 = Option “E” with Traq
- 4 = Option “F” with Traq
- 5 = Option “G” with Traq
- 6 = Option “H” with Traq
- 7 = Option “C” with Traq w/ Ultra Low Leak Outside Air Damper
- 8 = Option “D” with Traq w/ Ultra Low Leak Outside Air Damper
- 9 = Option “E” with Traq w/ Ultra Low Leak Outside Air Damper

### Digit 16 – System Control

- 1 = Constant Volume w/Zone Temperature Control
- 2 = Constant Volume w/ Discharge Air Control
- 4 = VAV Supply Air Temperature Control w/Variable Frequency Drive w/o Bypass
- 5 = VAV Supply Air Temperature Control w/Variable Frequency Drive and Bypass
- 6 = Single Zone VAV w/VFD w/o Bypass
- 7 = Single Zone VAV w/VFD w/ Bypass



## Model Number Descriptions

- A = VAV Supply Air Temperature Control w/VFD w/o Bypass w/ Motor Shaft Grounding Ring
- B = VAV Supply Air Temperature Control w/VFD w/Bypass w/Motor Shaft Grounding Ring
- C = Single Zone VAV w/VFD w/o Bypass w/ Motor Shaft Grounding Ring
- D = Single Zone VAV w/VFD w/ Bypass w/Motor Shaft Grounding Ring

**Note:** Zone sensors are not included with option and must be ordered as a separate accessory.

### Miscellaneous Options

#### Digit 17

- A = Service Valves<sup>2</sup>

#### Digit 18

- B = Through the Base Electrical Provision

#### Digit 19

- C = Non-Fused Disconnect Switch w/External Handle

#### Digit 20

- D = Factory-Powered 15A GFI Convenience Outlet and Non-Fused Disconnect Switch w/External Handle

#### Digit 21

- E = Field-Powered 15A GFI Convenience Outlet

#### Digit 22

- F = Trane Communication Interface (TCI)

#### Digit 23

- G = Ventilation Override

#### Digit 24

- H = Hinged Service Access

#### Digit 25

- H = Condenser Hail Guards
- J = Condenser Coil Guards

#### Digit 26

- K = LCI (LonTalk)
- B = BACnet Communications Interface (BCI)

#### Digit 27

- 0 = 5kA SCCR
- D = High Fault 65kA SCCR Disconnect<sup>6</sup>
- E = High Fault 65kA SCCR Disconnect w/Powered Convenience Outlet<sup>6</sup>

#### Digit 28

- 0 = Standard Drain Pan
- M = Stainless Steel Drain Pan
- 1 = Standard Drain Pan w/ Condensate Overflow Switch

- 2 = Stainless Steel Drain Pan w/ Condensate Overflow Switch

### Digit 29 – Efficiency/ Condenser Coil Options

- 0 = Standard Efficiency Unit
- J = Standard Efficiency Unit w/ Corrosion Protected Condenser Coil
- K = High Efficiency Unit (eStage)
- L = High Efficiency Unit (eStage) w/ Corrosion Protected Condenser Coil

### Digit 30-31 – Miscellaneous Options

- P = Discharge Temperature Sensor
- R = Clogged Filter Switch

### Digit 32 – Dehumidification Option

- T = Modulating Hot Gas Reheat

### Digit 33 – Human Interface

- 5 = Touchscreen Human Interface, 5"

### Model Number Notes

1. All voltages are across the line starting only.
2. Option includes Liquid, Discharge, Suction Valves.
3. Electric Heat kW ratings are based upon voltage ratings of 208/240/480/600 V. For a 240 V heater derated to 208 V, the resulting kW rating decreases from 36 kW to 27 kW, and from 54 kW to 41 kW. Voltage offerings are as follows (see [Table 22](#), p. 56 for additional information):

	Electric Heater		KW			
	Rated	27/ 41/	36	54	72	90 108
	208	x	x			
27½ to 35	240	x	x			
	480	x	x	x	x	
	600		x	x	x	
40 and 50	208		x			
	240		x			
	480		x	x	x	x
	600		x	x	x	x

4. The service digit for each model number contains 32 digits; all 32 digits must be referenced.
5. Ventilation override exhaust mode is not available for the exhaust fan with fresh air tracking power exhaust. VOM is available for the exhaust fan without fresh air tracking power exhaust.

- 6. 575 VAC option is 25kA.

## Model Number Descriptions

Y	C	D	2	7	5	B	C	L	A	0	A	1
1	2	3	4	5	6	7	8	9	10	11	12	13

### 50 Hz Description

#### Digits 1, 2 – Unit Function

TC = DX Cooling, No Heat  
 TE = DX Cooling, Electric Heat  
 YC = DX Cooling, Natural Gas Heat

#### Digit 3 – Unit Airflow Design

D = Downflow Supply and Return  
 H = Horizontal Supply and Return  
 F = Horizontal Supply and Upflow Return  
 R = Downflow Supply and Horizontal Return

#### Digits 4, 5, 6 – Nominal Cooling Capacity

275 = 22.9 Tons (82 kW)  
 305 = 25.4 Tons (89 kW)  
 350 = 29.2 Tons (105 kW)  
 400 = 33.3 Tons (120 kW)  
 500 = 41.7 Tons (148 kW)

#### Digit 7 – Major Development Sequence

B = R-410A Refrigerant

#### Digit 8 – Power Supply<sup>1</sup>

C = 380/50/3  
 D = 415/50/3

#### Digit 9 – Heating Capacity<sup>3</sup>

0 = No Heat (TC only)  
 L = Low Heat (YC only)  
 H = High Heat (YC only)

**Note:** When second digit is "E" for Electric Heat, the following values apply in the ninth digit.

#### 380V / 415V

A = 23 kW / 27 kW  
 B = 34 kW / 40 kW  
 C = 45 kW / 54 kW  
 D = 56 kW / 67 kW  
 E = 68 kW / 81 kW

#### Digit 10 – Design Sequence

A = First

#### Digit 11 – Exhaust<sup>5</sup>

0 = None  
 1 = Barometric Relief (Available w/Economizer only)  
 2 = 100% Power Exhaust Fan (Available w/ Economizer only)  
 3 = 50% Power Exhaust Fan (Available w/ Economizer only)  
 4 = 100% Fresh Air Tracking Power Exhaust Fan (Available w/Economizer only)  
 5 = 50% Fresh Air Tracking Power Exhaust Fan (Available w/ Economizer only)  
 6 = 100% Power Exhaust w/ Statitrac™

7 = 100% Power Exhaust Fan w/ Ultra Low Leak Exhaust Damper (Available w/ Economizer Only)  
 8 = 50% Power Exhaust Fan w/ Ultra Low Leak Exhaust Damper (Available w/ Economizer Only)  
 9 = 100% Power Exhaust w/ Ultra Low Leak Exhaust Damper w/ Statitrac™

#### Digit 12 – Filter

A = 2" (51 MM) MERV 4, Std Eff, Throwaway Filters  
 B = 2" (51 MM) MERV 8, High Eff, Throwaway Filters  
 C = 4" (102 MM) MERV 8, High Eff, Throwaway Filters  
 D = 4" (102 MM) MERV 14, High Eff, Throwaway Filters

#### Digit 13 – Supply Fan Motor, HP

1 = 7.5 Hp (5.6 kW)  
 2 = 10 Hp (7.5 kW)  
 3 = 15 Hp (10 kW)  
 4 = 20 Hp (15 kW)

#### Digit 14 – Supply Air Fan Drive Selections

A = 458 RPM	H = 417 RPM
B = 500 RPM	J = 437 RPM
C = 541 RPM	K = 479 RPM
D = 583 RPM	L = 521 RPM
E = 625 RPM	M = 562 RPM
F = 658 RPM	N = 604 RPM
G = 664 RPM	

#### Digit 15 – Fresh Air Selection

A = No Fresh Air  
 B = 0-25% Manual Damper  
 C = 0-100% Economizer, Dry Bulb Control  
 D = 0-100% Economizer, Reference Enthalpy Control  
 E = 0-100% Economizer, Differential Enthalpy Control  
 F = "C" Option and Low Leak Fresh Air Damper  
 G = "D" Option and Low Leak Fresh Air Damper  
 H = "E" Option and Low Leak Fresh Air Damper  
 J = "C" Option and Ultra Low Leak Outside Air Damper  
 K = "D" Option and Ultra Low Leak Outside Air Damper  
 L = E Option and Ultra Low Leak Outside Air Damper  
 1 = Option "C" with Traq  
 2 = Option "D" with Traq  
 3 = Option "E" with Traq  
 4 = Option "F" with Traq  
 5 = Option "G" with Traq  
 6 = Option "H" with Traq

7 = Option "C" with Traq w/ Ultra Low Leak Outside Air Damper  
 8 = Option "D" with Traq w/ Ultra Low Leak Outside Air Damper  
 9 = Option "E" with Traq w/ Ultra Low Leak Outside Air Damper

#### Digit 16 – System Control

1 = Constant Volume w/ Zone Temperature Control  
 2 = Constant Volume w/ Discharge Air Control  
 4 = VAV Supply Air Temperature Control w/Variable Frequency Drive w/o Bypass  
 5 = VAV Supply Air Temperature Control w/Variable Frequency Drive and Bypass  
 6 = Single Zone VAV w/VFD w/o Bypass  
 7 = Single Zone VAV w/VFD w/ Bypass  
 A = VAV Supply Air Temperature Control w/VFD w/o Bypass w/ Motor Shaft Grounding Ring  
 B = VAV Supply Air Temperature Control w/VFD w/Bypass w/Motor Shaft Grounding Ring  
 C = Single Zone VAV w/VFD w/o Bypass w/ Motor Shaft Grounding Ring  
 D = Single Zone VAV w/VFD w/ Bypass w/Motor Shaft Grounding Ring

**Note:** Zone sensors are not included with option and must be ordered as a separate accessory.

#### Miscellaneous Options

##### Digit 17

A = Service Valves<sup>2</sup>

##### Digit 18

B = Through the Base Electrical Provision

##### Digit 19

C = Non-Fused Disconnect Switch with External Handle

##### Digit 20

\* = Unused Digit

##### Digit 21

\* = Unused Digit

##### Digit 22

F = Trane Communication Interface (TCI)

##### Digit 23

G = Ventilation Override

##### Digit 24

H = Hinged Service Access



## Model Number Descriptions

---

### Digit 25

- H = Condenser Hail Guards
- J = Condenser Coil Guards

### Digit 26

- K = LCI (LonTalk)
- B = BACnet Communications Interface (BCI)

### Digit 27

- 0 = 5kA SCCR
- D = High Fault 65kA SCCR Disconnect

### Digit 28

- 0 = Standard Drain Pan
- M = Stainless Steel Drain Pan
- 1 = Pre-Painted Steel Drain Pan w/ Condensate Overflow Switch
- 2 = Stainless Steel Drain Pan w/ Condensate Overflow Switch

### Digit 29 – Efficiency/ Condenser Coil Options

- 0 = Standard Efficiency Unit
- J = Standard Efficiency Unit w/ Corrosion Protected Condenser Coil
- K = High Efficiency Unit (eStage)
- L = High Efficiency Unit (eStage) w/ Corrosion Protected Condenser Coil

### Digit 30-31 – Miscellaneous Options

- P = Discharge Temperature Sensor
- R = Clogged Filter Switch

### Digit 32 – Dehumidification Option

- T = Modulating Hot Gas Reheat

### Digit 33 – Human Interface

- 5 = Touchscreen Human Interface, 5"

### Model Number Notes

1. All voltages are across-the-line starting only.
2. Option includes Liquid, Discharge, Suction Valves.
3. Electric Heat kW ratings are based upon voltage ratings of 380/415 V. Heaters A, B, C, D are used with 22.9-29.2 ton (82-105 kW) units only and heaters B, C, D, E are used with 33.3-41.7 ton (120-148 kW) units only.
4. The service digit for each model number contains 32 digits; all 32 digits must be referenced.
5. Ventilation override exhaust mode is not available for the exhaust fan with fresh air tracking power exhaust. VOM is available for the exhaust fan without fresh air tracking power exhaust.





# General Data

**Table 1. General data - 27½ - 30 tons (60 Hz)**

	27½ Ton				30 Ton			
<b>Cooling Performance<sup>1</sup></b>								
Nominal Gross Capacity - Std Efficiency	323,000				353,000			
Nominal Gross Capacity - High Efficiency	342,000				360,000			
<b>Natural Gas Heat<sup>2,6</sup></b>	<b>Two Stage</b>		<b>Modulating</b>		<b>Two Stage</b>		<b>Modulating</b>	
	<b>Low</b>	<b>High</b>	<b>Low</b>	<b>High</b>	<b>Low</b>	<b>High</b>	<b>Low</b>	<b>High</b>
Heating Input (BTUH)	350,000	600,000	350,000	600,000	350,000	600,000	350,000	600,000
Heating Output (BTUH)	280,000	480,000	280,000	480,000	280,000	480,000	280,000	480,000
Steady State Efficiency (%) <sup>3</sup>	80.00	80.00	80.00	80.00	80.00	80.00	80.00	80.00
No. Burners	1	2	1	2	1	2	1	1
No. Stages/Turn down rate	2	2	2.5:1	5:1	2	2	2.5:1	5:1
<b>Gas Supply Pressure (in. w.c.)</b>								
Natural or LP (Two Stage only) (min/max) 2.5/14.0	2.5/14.0	2.5/14.0	2.5/14.0	2.5/14.0	2.5/14.0	2.5/14.0	2.5/14.0	2.5/14.0
Gas Connection Pipe Size (in.)	3/4	1	3/4	1	3/4	1	3/4	1
<b>Electric Heat</b>								
kW Range <sup>4</sup>	27-90				27-90			
Capacity Steps	2				2			
<b>Compressor - Std Efficiency</b>								
Qty/Type/Refrigerant/Circuits	2/Scroll/R-410A/1				2/Scroll/R-410A/1			
Size (Nominal)	12/13				13			
Unit Capacity Steps (%)	100/48				100/50			
<b>Compressor - High Efficiency, eStage</b>								
Qty/Type/Refrigerant/Circuits	3/Scroll/R-410A/1				3/Scroll/R-410A/1			
Size (Nominal)	6/9/9				6/10/10			
Unit Capacity Steps (%)	100/75/63/37/25				100/76/62/38/24			
<b>Outdoor Coil - Std Efficiency</b>								
Type	Microchannel				Microchannel			
Face Area (sq. ft.)	43.6				49.9			
Rows	1				1			
<b>Outdoor Coil - High Efficiency</b>								
Type	Microchannel				Microchannel			
Face Area (sq. ft.)	49.9				49.9			
Rows	1				1			
<b>Indoor Coil - Std Efficiency</b>								
Tube Size (in.) OD	3/8				3/8			
Face Area (sq. ft.)	31.7				31.7			
Rows/Fins Per Foot	3/180				3/180			
Refrigerant Control	TXV				TXV			
No. of Circuits	1				1			
Drain Connection No./Size (in)	1/1.25				1/1.25			
Type	PVC				PVC			



## General Data

**Table 1. General data - 27½ - 30 tons (60 Hz)**

	<b>27½ Ton</b>	<b>30 Ton</b>
<b>Indoor Coil - High Efficiency</b>		
Tube Size (in.) OD	3/8	3/8
Face Area (sq. ft.)	31.7	31.7
Rows/Fins Per Foot	4/180	4/180
Refrigerant Control	TXV	TXV
Drain Connection No./Size (in)	1/1.25	1/1.25
Type	PVC	PVC
<b>Outdoor Fan Type</b>		
No. Used/Diameter	3/28.00	3/28.00
Drive Type/No. Speeds	Direct/1	Direct/1
CFM	25,800	25,800
No. Motors/HP/RPM	3/1.10/1125	3/1.10/1125
<b>Indoor Fan Type</b>		
No. Used	1	1
Diameter/Width (in)	22.38/22.00	22.38/22.00
Drive Type/No. Speeds	Belt/1	Belt/1
No. Motors/HP Range	1/7.50-10.00	1/7.50-15.00
CFM Range <sup>7</sup>	8000-12100	9000-13200
<b>Exhaust Fan Type</b>		
Diameter (in)	26.00	26.00
Drive Type/No. Speeds/Motor Frame Size	Direct/1/56	Direct/1/56
Motor HP/RPM	1.0/1140	1.0/1140
<b>Filters - Type Furnished</b>		
No./ Recommended Size (in) <sup>5</sup>	16/16 x 20 x 2	16/16 x 20 x 2
<b>Min. Outside Air Temp for Mechanical Cooling</b>		
	0°F	0°F
<b>Refrigerant Charge - Std Efficiency (Pounds of R-410A)</b>		
Standard	24.6	29.3
Optional Hot Gas Reheat	26.9	31.3
<b>Refrigerant Charge - High Efficiency (Pounds of R-410A)</b>		
Standard	37.8	37.8
Optional Hot Gas Reheat	40.8	40.8

**Notes:**

- Cooling Performance is rated at 95°F ambient, 80°F entering dry bulb, 67°F entering wet bulb. Gross capacity does not include the effect of fan motor heat. Rated and tested in accordance with the Unitary Large Equipment certification program, which is based on ARI Standard 340/360-93.
- Heating Performance limit settings and rating data were established and approved under laboratory test conditions using American National Standards Institute standards. Ratings shown are for elevations up to 4,500 feet.
- Steady State Efficiency is rated in accordance with DOE test procedures.
- Maximum KW @ 208V = 41, @ 240V = 54. For Electric heat KW range per specific voltage, see [Table 22, p. 56](#).
- Filter dimensions listed are nominal. For actual filter and rack sizes see the Unit Installation, Operation, Maintenance Guide.
- Standard gas furnaces: Second Stage is total heating capacity—Second Stage/First Stage; Modulating gas furnaces: High Fire is total heating capacity—High Fire/Low Fire.
- Cooling only CFM range

**Table 2. General data — 35 - 40 tons (60 Hz)**

	<b>35 Ton</b>				<b>40 Ton</b>			
<b>Cooling Performance<sup>1</sup></b>								
Nominal Gross Capacity - Std Efficiency	407,000				475,000			
Nominal Gross Capacity - High Efficiency	407,000				479,000			
<b>Natural Gas Heat<sup>2,6</sup></b>	<b>Two Stage</b>		<b>Modulating</b>		<b>Two Stage</b>		<b>Modulating</b>	
	<b>Low</b>	<b>High</b>	<b>Low</b>	<b>High</b>	<b>Low</b>	<b>High</b>	<b>Low</b>	<b>High</b>
Heating Input (BTUH)	350,000	600,000	350,000	600,000	400,000	800,000	350,000	750,000
Heating Output (BTUH)	280,000	480,000	280,000	480,000	320,000	640,000	280,000	600,000
Steady State Efficiency (%) <sup>3</sup>	80.00	80.00	80.00	80.00	80.00	80.00	80.00	80.00
No. Burners	1	2	1	2	1	2	1	1
No. Stages/Turn Down Rate	2	2	2.5:1	5:1	2	2	2.5:1	5:1
<b>Gas Supply Pressure (in. w.c.)</b>								
Natural or LP (Two Stage only) (min/max)	2.5/14.0				2.5/14.0			
Gas Connection Pipe Size (in.)	3/4	1	3/4	1	3/4	1	3/4	1
<b>Electric Heat</b>								
kW Range <sup>4</sup>	27-90				41-108			
Capacity Steps:	2				2			
<b>Compressor - Std Efficiency</b>								
Qty/Type/Refrigerant/Circuits	2/Scroll/R-410A/1				2/Scroll/R-410A/2			
Size (nominal)	13/15				13/20			
Unit Capacity Steps (%)	100/47				100/60/40			
<b>Compressor - High Efficiency, eStage</b>								
Qty/Type/Refrigerant/Circuits	3/Scroll/R-410A/1				3/Scroll/R-410A/1			
Size (nominal)	6/11/11				8/13/13			
Unit Capacity Steps (%)	100/78/61/39/22				100/77/61/39/23			
<b>Outdoor Coil - Std Efficiency</b>								
Type	Microchannel				Microchannel			
Face Area	49.9				51.2			
Rows	1				2			
<b>Outdoor Coil - High Efficiency</b>								
Type	Microchannel				Microchannel			
Face Area	49.9				51.2			
Rows	1				1			
<b>Indoor Coil - Std Efficiency</b>								
Tube Size (in.) OD	3/8				3/8			
Face Area (sq. ft.)	31.7				36.7			
Rows/Fins Per Foot	4/180				4/180			
Refrigerant Control	TXV				TXV			
Drain Connection No./Size (in)	1/1.25				1/1.25			
Type	PVC				PVC			



## General Data

**Table 2. General data — 35 - 40 tons (60 Hz)**

	<b>35 Ton</b>	<b>40 Ton</b>
<b>Indoor Coil - High Efficiency</b>		
Tube Size (in.) OD	3/8	3/8
Face Area (sq. ft.)	31.7	36.7
Rows/Fins Per Foot	4/180	5/180
Refrigerant Control	TXV	TXV
No. of Circuits	1	1
Drain Connection No./Size (in)	1/1.25	1/1.25
Type	PVC	PVC
<b>Outdoor Fan Type</b>		
No. Used/Diameter	3/28.00	4/28.00
Drive Type/No. Speeds	Direct/1	Direct/1
CFM	25,800	27,400
No. Motors/HP/RPM	3/1.10/1125	4/1.10/1125
<b>Indoor Fan Type</b>		
No. Used	1	1
Diameter/Width (in)	22.38/22.00	25.00/25.00
Drive Type/No. Speeds	Belt/1	Belt/1
No. Motors/HP Range	1/7.50/10.00-15.00	1/10.00-15.00
CFM Range <sup>7</sup>	10500-14400	12000-17600
<b>Exhaust Fan Type</b>		
Diameter (in)	26.00	28.00
Drive Type/No. Speeds/Motor Frame Size	Direct/1/56	Direct/1/56
Motor HP/RPM	1.0/1140	1.5/1140
<b>Filters - Type Furnished</b>		
No./Recommended Size (in) <sup>5</sup>	16/16 x 20 x 2	17/16 x 20 x 2
<b>Min. Outside Air Temp for Mechanical Cooling</b>		
	0°F	0°F
<b>Refrigerant Charge - Std Efficiency (Pounds of R-410A)</b>		
Standard	33.3	Ckt.1: 19.4 / Ckt.2: 37.0
Optional Hot Gas Reheat	36.3	Ckt.1: 19.4 / Ckt.2: 39.2
<b>Refrigerant Charge - High Efficiency (Pounds of R-410A)</b>		
Standard	38.3	61
Optional Hot Gas Reheat	41.3	67.1

**Notes:**

- Cooling Performance is rated at 95°F ambient, 80°F entering dry bulb, 67°F entering wet bulb. Gross capacity does not include the effect of fan motor heat. Rated and tested in accordance with the Unitary Large Equipment certification program, which is based on ARI Standard 340/360-93.
- Heating Performance limit settings and rating data were established and approved under laboratory test conditions using American National Standards Institute standards. Ratings shown are for elevations up to 4,500 feet.
- Steady State Efficiency is rated in accordance with DOE test procedures.
- Maximum KW @ 208V = 41, @ 240V = 54. For Electric heat KW range per specific voltage, see [Table 22, p. 56](#).
- Filter dimensions listed are nominal. For actual filter and rack sizes see the Unit Installation, Operation, Maintenance Guide.
- Standard gas furnaces: Second Stage is total heating capacity—Second Stage/First Stage; Modulating gas furnaces: High Fire is total heating capacity—High Fire/Low Fire.
- Cooling only CFM range.

**Table 3. General data — 50 tons (60 Hz)**

	<b>50 Ton</b>			
<b>Cooling Performance<sup>1</sup></b>				
Nominal Gross Capacity - Std Efficiency	588,000			
Nominal Gross Capacity - High Efficiency	588,000			
	<b>Two Stage</b>		<b>Modulating</b>	
	<b>Low</b>	<b>High</b>	<b>Low</b>	<b>High</b>
<b>Natural Gas Heat<sup>2,6</sup></b>				
Heating Input (BTUH)	400,000	800,000	350,000	750,000
Heating Output (BTUH)	320,000	640,000	280,000	600,000
Steady State Efficiency (%) <sup>3</sup>	80.00	80.00	80.00	80.00
No. Burners	1	2	1	1
No. Stages/Turn Down Rate	2	2	2.5:1	5:1
<b>Gas Supply Pressure (in. w.c.)</b>				
Natural or LP (Two Stage only) (min/max)	2.5/14.0	2.5/14.0	2.5/14.0	2.5/14.0
Gas Connection Pipe Size (in.)	3/4	1	3/4	1
<b>Electric Heat</b>				
kW Range <sup>4</sup>	41-108			
Capacity Steps:	2			
<b>Compressor - Std Efficiency</b>				
Qty/Type/Refrigerant/Circuits	3/Scroll/R-410A/2			
Size (nominal)	13/13/15			
Unit Capacity Steps (%)	100/68/32			
<b>Compressor - High Efficiency, eStage</b>				
Qty/Type/Refrigerant/Circuits	3/Scroll/R-410A/1			
Size (nominal)	10/15/15			
Unit Capacity Steps (%)	100/75/62/38/25			
<b>Outdoor Coil - Std Efficiency</b>				
Type	Microchannel			
Face Area	65.4			
Rows	2			
<b>Outdoor Coil - High Efficiency</b>				
Type	Microchannel			
Face Area	65.4			
Rows	2			
<b>Indoor Coil - Std Efficiency</b>				
Tube Size (in.) OD	3/8			
Face Area (sq. ft.)	36.7			
Rows/Fins Per Foot	5/180			
Refrigerant Control	TXV			
Drain Connection No./Size (in)	1/1.25			
Type	PVC			



## General Data

**Table 3. General data — 50 tons (60 Hz)**

	<b>50 Ton</b>
<b>Indoor Coil - High Efficiency</b>	
Tube Size (in.) OD	3/8
Face Area (sq. ft.)	36.7
Rows/Fins Per Foot	5/180
Refrigerant Control	TXV
No. of Circuits	2
Drain Connection No./Size (in)	1/1.25
Type	PVC
<b>Outdoor Fan Type</b>	
No. Used/Diameter	4/28.00
Drive Type/No. Speeds	Direct/1
CFM	31,500
No. Motors/HP/RPM	4/1.10/1125
<b>Indoor Fan Type</b>	
No. Used	1
Diameter/Width (in)	25.00/25.00
Drive Type/No. Speeds	Belt/1
No. Motors/HP Range	1/10.00/15.00-20.00
CFM Range <sup>7</sup>	15000-20000
<b>Exhaust Fan Type</b>	
Diameter (in)	28.00
Drive Type/No. Speeds/Motor Frame Size	Direct/1/56
Motor HP/RPM	1.5/1140
<b>Filters - Type Furnished</b>	
No./Recommended Size (in) <sup>5</sup>	17/16 x 20 x 2
<b>Min. Outside Air Temp for Mechanical Cooling</b>	
	0°F
<b>Refrigerant Charge - Std Efficiency (Pounds of R-410A)</b>	
Standard	Ckt.1: 20.0 / Ckt.2: 38.8
Optional Hot Gas Reheat	Ckt.1: 20.0 / Ckt.2: 42.3
<b>Refrigerant Charge - High Efficiency (Pounds of R-410A)</b>	
Standard	55.6
Optional Hot Gas Reheat	61.2

**Notes:**

- Cooling Performance is rated at 95°F ambient, 80°F entering dry bulb, 67°F entering wet bulb. Gross capacity does not include the effect of fan motor heat. Rated and tested in accordance with the Unitary Large Equipment certification program, which is based on ARI Standard 340/360-93.
- Heating Performance limit settings and rating data were established and approved under laboratory test conditions using American National Standards Institute standards. Ratings shown are for elevations up to 4,500 feet.
- Steady State Efficiency is rated in accordance with DOE test procedures.
- Maximum KW @ 208V = 41, @ 240V = 54. For Electric heat KW range per specific voltage, see [Table 22, p. 56](#).
- Filter dimensions listed are nominal. For actual filter and rack sizes see the Unit Installation, Operation, Maintenance Guide.
- Standard gas furnaces: Second Stage is total heating capacity—Second Stage/First Stage; Modulating gas furnaces: High Fire is total heating capacity—High Fire/Low Fire.
- Cooling only CFM range.

**Table 4. Economizer outdoor air damper leakage (of rated airflow) (60 Hz)**

	<b>ΔP Across Dampers (in. WC)</b>	
	<b>0.5 (In.)</b>	<b>1.0 (In.)</b>
<b>Standard</b>	1.5%	2.5%
<b>Low Leak</b>	0.5%	1.0%
<b>Ultra Low Leak</b>	0.0%	0.1%

**Notes:**

1. Standard and Low Leak data based on tests completed in accordance with AMCA Standard 500.
2. Ultra Low Leak dampers are rated AMCA class 1A; leak rate = 3 CFM per sq-ft face area at 1.0" WC.



## General Data

**Table 5. General data – 22.9 - 25.4 tons (50 Hz)**

	<b>TC/YC/TE*275 (22.9 Tons)</b>		<b>TC/YC/TE*305 (25.4 Tons)</b>	
<b>Cooling Performance<sup>1</sup></b>				
Nominal Gross Capacity	277,000 (81.16 kW)		303,000 (88.78 kW)	
<b>Compressor - Standard Efficiency</b>				
Qty/Type/Refrigerant/Circuits	2/Scroll/R-410A/1		2/Scroll/R-410A/1	
Size (Nominal Tons)	10/11		11/11	
Unit Capacity Steps (%)	100/48		100/50	
<b>Compressor - High Efficiency, eStage</b>				
Qty/Type/Refrigerant/Circuits	3/Scroll/R-410A/1		3/Scroll/R-410A/1	
Size (Nominal Tons)	6/9/9		6/10/10	
Unit Capacity Steps (%)	100/75/63/37/25		100/76/62/38/24	
<b>Natural Gas Heat<sup>2</sup></b>	Low	High	Low	High
Heating Input - Btu (kW)	290,000 (85.0)	500,000 (147)	290,000 (85.0)	500,000 (147)
Heating Output - Btu (kW)	232,000 (55.2)	400,000 (118)	232,000 (55.2)	400,000 (118)
Steady State Efficiency(%) <sup>3</sup>	80		80	
No. Burners/No. Stages	1/2		1/2	
Gas Connect Pipe Size - in. (mm)	0.75 (19)		0.75 (19)	
<b>Outdoor Coil - Standard Efficiency</b>				
Type	Microchannel		Microchannel	
Face Area - sq ft (sq m)	43.6 (4.0)		49.9 (4.6)	
Rows	1		1	
<b>Outdoor Coil - High Efficiency</b>				
Type	Microchannel		Microchannel	
Face Area - sq ft (sq m)	49.9 (4.6)		49.9 (4.6)	
Rows	1		1	
<b>Indoor Coil - Standard Efficiency</b>				
Tube Size OD - in. (mm)	0.375 (9.5)		0.375 (9.5)	
Face Area - sq ft (sq m)	31.7 (2.9)		31.7 (2.9)	
Rows/Fins Per Foot	3/180		3/180	
Refrigerant Control	TXV		TXV	
PVC Drain Connect No./Size - in. (mm)	1/1.25 (1/32)		1/1.25 (1/32)	
<b>Indoor Coil - High Efficiency</b>				
Tube Size OD - in. (mm)	0.375 (9.5)		0.375 (9.5)	
Face Area - sq ft (sq m)	31.7 (2.9)		31.7 (2.9)	
Rows/Fins Per Foot	4/180		4/180	
Refrigerant Control	TXV		TXV	
PVC Drain Connect No./Size - in. (mm)	1/1.25 (1/32)		1/1.25 (1/32)	
<b>Outdoor Fan Type</b>	Propeller		Propeller	
No. Used	3		3	
Diameter - in. (mm)	28.0 (711)		28.0 (711)	
Drive Type/No. Speeds	Direct/1		Direct/1	
cfm (L/s)	25,800 (12176)		25,800 (12176)	
No. Motors (rpm)	3 (940)		3 (940)	
Motor- hp (kW)	0.75 (0.56)		0.75 (0.56)	
<b>Indoor Fan Type/No. Used</b>	FC/1		FC/1	
Diameter - in. (mm)	22.4 (568)		22.4 (568)	
Width - in. (mm)	22.0 (559)		22.0 (559)	
Drive Type	Belt		Belt	
No. Speeds/No. Motors	1/1		1/1	
Motor - hp (kW)	7.5 (5.6)		7.5 (5.6)	



**Table 5. General data — 22.9 - 25.4 tons (50 Hz)**

	<b>TC/YC/TE*275 (22.9 Tons)</b>	<b>TC/YC/TE*305 (25.4 Tons)</b>
<b>Exhaust Fan Type</b>	Propeller	Propeller
Diameter-in (mm)	26.00(660)	26.00(660)
Drive Type/No. Speeds/Motor Frame Size	Direct/1/56	Direct/1/56
Motor-HP (kW)/RPM	.75(.56)/950	75(.56)/950
<b>Filters - Type Furnished</b>	Throwaway	Throwaway
No.	16	16
Recommended Size - in. (mm)	16 x 20 x 2 (406 x 508 x 51)	16 x 20 x 2 (406 x 508 x 51)
<b>Refrigerant Charge (lb. R-410A) - Standard Efficiency</b>		
Standard	24.6	29.3
Optional Hot Gas Reheat	26.9	31.3
<b>Refrigerant Charge (lb. R-410A) - High Efficiency</b>		
Standard	37.8	37.8
Optional Hot Gas Reheat	40.8	40.8

**Notes:**

1. Cooling Performance is rated at 95°F (35°C) ambient, 80°F (27°C) entering dry bulb, 67°F (19°C) entering wet bulb. Gross capacity does not include the effect of fan motor heat.
2. Heating Performance Limit settings and ratings data were established and approved under laboratory test conditions using American National Standards.
3. Steady State Efficiency is rated in accordance with DOE test procedures.



## General Data

**Table 6. General data — 29.2 - 41.7 tons (50 Hz)**

	<b>TC/YC/TE*350 (29.2 Tons)</b>		<b>TC/YC/TE*400 (33.3 Tons)</b>		<b>TC/YC/TE*500 (41.7 Tons)</b>	
<b>Cooling Performance<sup>1</sup></b>						
Nominal Gross Capacity	353,000 (103.43 kW)		400,000 (117.2 kW)		500,000 (146.5 kW)	
<b>Compressor - Std Eff</b>						
Qty/Type/Refrigerant/ Circuits	2/Scroll/R-410A/1		2/Scroll/R-410A/2		3/Scroll/R-410A/2	
Size (Nominal Tons)	11/12		11/17		11/11/12	
Unit Capacity Steps (%)	100/47		100/60/40		100/68/32	
<b>Compressor - High Eff, eStage</b>						
Qty/Type/Refrigerant/ Circuits	3/Scroll/R-410A/1		3/Scroll/R-410A/1		3/Scroll/R-410A/1	
Size (Nominal Tons)	6/11/11		8/13/13		10/15/15	
Unit Capacity Steps (%)	100/78/61/39/22		100/77/61/39/23		100/75/62/38/25	
<b>Natural Gas Heat<sup>2</sup></b>	Low	High	Low	High	Low	High
Heating Input - Btu (kW)	290,000 (85.0)	500,000 (147)	335,000 (98.2)	670,000 (196)	335,000 (98.2)	670,000 (196)
Heating Output - Btu (kW)	232,000 (55.2)	400,000 (118)	268,000 (78.6)	536,000 (157)	268,000 (78.6)	536,000 (157)
Steady State Efficiency(%) <sup>3</sup>	80		80		80	
No. Burners/No. Stages	1/2		1/2		1/2	
Gas Connect Pipe Size - in. (mm)	0.75 (19)		0.75 (19)		0.75 (19)	
<b>Outdoor Coil - Std Eff</b>						
Type	Microchannel		Microchannel		Microchannel	
Face Area - sq ft (sq m)	49.9 (4.6)		51.2 (4.8)		65.4 (6.1)	
Rows/Fins Per Foot	1		2		2	
<b>Outdoor Coil - High Eff</b>						
Type	Microchannel		Microchannel		Microchannel	
Face Area - sq ft (sq m)	49.9 (4.6)		65.4 (6.1)		65.4 (6.1)	
Rows/Fins Per Foot	1		2		2	
<b>Indoor Coil - Std Eff</b>						
Tube Size OD - in. (mm)	0.375 (9.5)		0.375 (9.5)		0.375 (9.5)	
Face Area - sq ft (sq m)	31.7 (2.9)		36.7 (3.4)		36.7 (3.4)	
Rows/Fins Per Foot	4/180		4/180		5/180	
Refrigerant Control	TXV		TXV		TXV	
PVC Drain Connect No./Size - in. (mm)	1/1.25 (1/32)		1/1.25 (1/32)		1/1.25 (1/32)	
<b>Indoor Coil - High Eff</b>						
Tube Size OD - in. (mm)	0.375 (9.5)		0.375 (9.5)		0.375 (9.5)	
Face Area - sq ft (sq m)	31.7 (2.9)		36.7 (3.4)		36.7 (3.4)	
Rows/Fins Per Foot	4/180		5/180		5/180	
Refrigerant Control	TXV		TXV		TXV	
PVC Drain Connect No./Size - in. (mm)	1/1.25 (1/32)		1/1.25 (1/32)		1/1.25 (1/32)	
<b>Outdoor Fan Type</b>	Propeller		Propeller		Propeller	
No. Used	3		4		4	
Diameter - in. (mm)	28.0 (711)		28.0 (711)		28.0 (711)	
Drive Type/No. Speeds	Direct/1		Direct/1		Direct/1	
cfm (L/s)	25,800 (12176)		27,400 (12931)		31,500 (14866)	
No. Motors (rpm)	3 (940)		4 (940)		4 (940)	
Motor- hp (kW)	0.75 (0.56)		0.75 (0.56)		0.75 (0.56)	

**Table 6. General data – 29.2 - 41.7 tons (50 Hz)**

	<b>TC/YC/TE*350 (29.2 Tons)</b>	<b>TC/YC/TE*400 (33.3 Tons)</b>	<b>TC/YC/TE*500 (41.7 Tons)</b>
<b>Indoor Fan Type/No. Used</b>	FC/1	FC/1	FC/1
Diameter - in. (mm)	22.4 (568)	25.0 (635)	25.0 (635)
Width - in. (mm)	22.0 (559)	25.0 (635)	25.0 (635)
Drive Type	Belt	Belt	Belt
No. Speeds/No. Motors	1/1	1/1	1/1
Motor - hp (kW)	7.5 (5.6)	10.0 (7.5)	10.0 (7.5 kW)
<b>Exhaust Fan Type</b>	Propeller	Propeller	Propeller
Diameter-in (mm)	26.00(660)	28.00(711)	28.00(711)
Drive Type/No. Speeds/ Motor Frame Size	Direct/1/56	Direct/1/56	Direct/1/56
Motor-HP (kW)/RPM	0.75(.56)/950	1.0(.75)/950	1.0(.75)/950
<b>Filters - Type Furnished</b>	Throwaway	Throwaway	Throwaway
No.	16	17	17
Recommended Size - in. (mm)	16 x 20 x 2 (406 x 508 x 51)	16 x 20 x 2 (406 x 508 x 51)	16 x 20 x 2 (406 x 508 x 51)
<b>Refrigerant Charge (lb. R-410A) - Std Eff</b>			
Standard	33.3	Ckt.1: 19.4 / Ckt.2: 37.0	Ckt.1: 20.0 / Ckt.2: 38.8
Optional Hot Gas Reheat	36.3	Ckt.1: 19.4 / Ckt.2: 39.2	Ckt.1: 20.0 / Ckt.2: 42.3
<b>Refrigerant Charge (lb. R-410A) - High Eff</b>			
Standard	38.3	61	55.6
Optional Hot Gas Reheat	41.3	67.1	61.2

**Notes:**

1. Cooling Performance is rated at 95°F (35°C) ambient, 80°F (27°C) entering dry bulb, 67°F (19°C) entering wet bulb. Gross capacity does not include the effect of fan motor heat.
2. Heating Performance Limit settings and ratings data were established and approved under laboratory test conditions using American National Standards.
3. Steady State Efficiency is rated in accordance with DOE test procedures.

**Table 7. Economizer outdoor air damper leakage (of rated airflow) (50 Hz)**

	<b>ΔP Across Dampers (in. WC)</b>	
	<b>0.5 (In.)</b>	<b>1.0 (In.)</b>
<b>Standard</b>	1.5%	2.5%
<b>Low Leak</b>	0.5%	1.0%
<b>Ultra Low Leak</b>	0.0%	0.1%

**Notes:**

1. Standard and Low Leak data based on tests completed in accordance with AMCA Standard 500.
2. Ultra Low Leak dampers are rated AMCA class 1A; leak rate = 3 CFM per sq-ft face area at 1.0" WC.

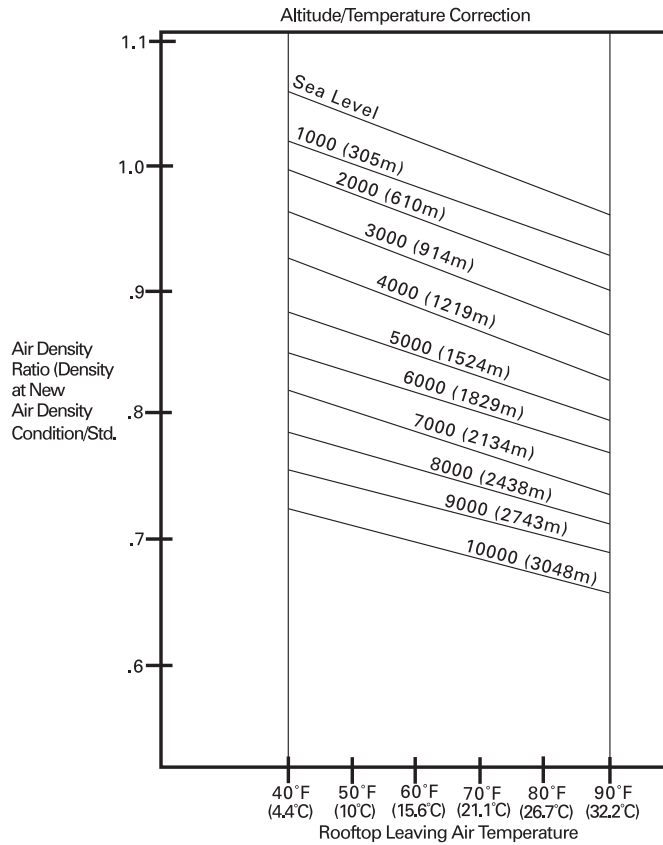


# Performance Adjustment Factors

**Table 8. Enthalpy of saturated air**

Wet Bulb Temperature		Btu Per lb
°F	°C	
40	4.4	15.23
41	5.0	15.70
42	5.5	16.17
43	6.1	16.66
44	6.7	17.15
45	7.2	17.65
46	7.8	18.16
47	8.3	18.68
48	8.9	19.21
49	9.4	19.75
50	10.0	20.30
51	10.6	20.86
52	11.1	21.44
53	11.7	22.02
54	12.2	22.62
55	12.8	23.22
56	13.3	23.84
57	13.9	24.48
58	14.4	25.12
59	15.0	25.78
60	15.6	26.46
61	16.1	27.15
62	16.7	27.85
63	17.2	28.57
64	17.8	29.31
65	18.3	30.06
66	18.9	30.83
67	19.4	31.62
68	20.0	32.42
69	20.6	33.25
70	21.1	34.09
71	21.7	34.95
72	22.2	35.83
73	22.8	36.74
74	23.3	37.66
75	23.9	38.61

**Figure 4. Air density ratios**



**Table 9. Cooling capacity altitude correction factors**

	Altitude ft. (m)							
	Sea Level	1000 (304.8)	2000 (609.6)	3000 (914.4)	4000 (1219.2)	5000 (1524.0)	6000 (1828.8)	7000 (2133.6)
Cooling Capacity Multiplier	1.00	0.99	0.99	0.98	0.97	0.96	0.95	0.94
KW Correction Multiplier (Compressors)	1.00	1.01	1.02	1.03	1.04	1.05	1.06	1.07
SHR Correction Multiplier	1.00	0.98	0.95	0.93	0.91	0.89	0.87	0.85
Maximum Condenser Ambient	115°F (46.1°C)	114°F (45.6°C)	113°F (45.0°C)	112°F (44.4°C)	111°F (43.9°C)	110°F (43.3°C)	109°F (42.8°C)	108°F (42.2°C)

**Note:** SHR = Sensible Heat Ratio

**Table 10. Gas heating capacity altitude correction factors**

	Altitude ft. (m)						
	Sea Level To 2000 (Sea Level To 609.6)	2000 To 2500 (609.9 To 762.0)	2501 To 3500 (762.3 To 1066.8)	3501 To 4500 (1067.1 To 1674.4)	4501 To 5500 (1371.9 To 1675.4)	5501 To 6500 (1676.7 To 1981.2)	6501 To 7500 (1981.5 To 2286.0)
Capacity Multiplier	1.00	.92	.88	.84	.80	.76	.72

**Note:** Correction factors are per AGA Std 221.30 – 1964, Part VI, 6.12. Local codes may supersede.



# Performance Data (60 Hz Units)

**Table 11. 27½ ton standard efficiency, gross cooling capacities (MBh)—1-row condenser coil—60 Hz**

Air Flow CFM	Ent DB (°F)	Ambient Temperature																	
		85						95						105					
		Entering Wet Bulb Temperature																	
		61		67		73		61		67		73		61		67		73	
TGC	SHC	TGC	SHC	TGC	SHC	TGC	SHC	TGC	SHC	TGC	SHC	TGC	SHC	TGC	SHC	TGC	SHC		
8000	75	292	229	322	180	354	126	277	220	305	171	334	117	260	210	286	162	313	107
	80	297	270	324	221	356	169	281	261	306	211	337	159	265	251	288	201	316	150
	85	305	305	326	260	358	210	291	291	309	250	339	201	276	276	291	240	318	191
	90	321	321	331	301	359	250	307	307	314	291	340	240	291	291	296	281	320	230
9000	75	300	243	329	190	360	128	283	233	311	181	340	119	266	223	292	171	319	110
	80	305	289	330	233	363	176	289	279	313	223	343	167	272	269	294	212	322	157
	85	317	317	334	277	366	222	302	302	317	267	346	213	286	286	298	257	323	202
	90	334	334	340	323	367	266	319	319	323	313	348	256	302	302	304	302	327	245
10000	75	306	256	334	199	366	131	289	246	316	190	345	122	272	235	296	180	323	112
	80	312	307	336	244	369	183	295	295	318	234	348	174	279	279	299	224	326	164
	85	328	328	341	294	371	234	312	312	323	283	350	223	295	295	304	273	328	212
	90	346	346	349	344	374	281	330	330	330	330	354	270	312	312	312	312	332	260
11000	75	311	269	339	208	370	133	294	258	320	198	349	124	276	248	300	189	326	115
	80	318	318	342	256	374	190	303	303	323	245	353	181	286	286	303	235	330	171
	85	337	337	347	310	376	243	321	321	329	299	355	233	303	303	309	288	333	222
	90	356	356	356	356	380	295	339	339	339	339	359	285	321	321	321	321	337	274
12100	75	316	282	343	217	374	136	299	272	324	208	352	127	281	261	302	193	329	117
	80	327	327	347	268	378	198	311	311	328	258	357	188	293	293	307	247	334	178
	85	346	346	353	327	380	254	329	329	334	316	359	243	311	311	314	305	337	232
	90	366	366	365	365	385	311	348	348	348	348	364	301	329	329	329	329	342	290

Air Flow CFM	Ent DB (°F)	Ambient Temperature					
		115					
		Entering Wet Bulb Temperature					
		61		67		73	
TGC	SHC	TGC	SHC	TGC	SHC		
8000	75	242	199	267	152	291	97.7
	80	247	240	268	190	294	140
	85	260	260	272	229	297	181
	90	274	274	277	270	298	219
9000	75	248	212	272	161	296	100
	80	254	254	274	201	299	147
	85	269	269	278	246	301	191
	90	285	285	285	285	304	234
10000	75	253	224	275	170	299	102
	80	262	262	278	212	303	154
	85	278	278	283	261	305	200
	90	293	293	293	293	309	248
11000	75	257	236	278	174	302	105
	80	268	268	282	223	306	161
	85	285	285	288	277	309	210
	90	301	301	301	301	314	262
12100	75	261	249	281	182	305	107
	80	275	275	286	235	308	165
	85	291	291	291	291	312	220
	90	308	308	308	308	318	277

**Notes:**  
**1.** All capacities shown are gross and have not considered indoor fan heat. To obtain net cooling, subtract indoor fan heat.  
**2.** TGC = Total gross capacity.  
**3.** SHC = Sensible heat capacity.

## Performance Data (60 Hz Units)

**Table 12. 27½ ton high efficiency - eStage, gross cooling capacities (MBh) – 1-row condenser coil – 60 Hz**

Air Flow CFM	Ent DB (°F)	Ambient Temperature																	
		85						95						105					
		Entering Wet Bulb Temperature																	
		61		67		73		61		67		73		61		67		73	
TGC	SHC	TGC	SHC	TGC	SHC	TGC	SHC	TGC	SHC	TGC	SHC	TGC	SHC	TGC	SHC	TGC	SHC		
8000	75	309	244	342	191	375	134	297	237	328	184	359	127	282	230	312	178	341	121
	80	314	289	343	234	377	178	302	282	329	228	361	172	288	275	314	220	343	165
	85	324	324	345	277	376	222	313	313	331	270	360	216	301	301	315	262	344	209
	90	341	341	346	319	378	265	330	330	332	312	363	258	316	316	316	305	345	250
9000	75	316	259	349	200	382	136	303	252	335	194	365	130	288	244	318	187	347	123
	80	323	310	351	248	384	186	310	303	336	241	367	180	295	295	320	233	349	173
	85	337	337	352	295	384	235	326	326	337	288	368	229	312	312	321	280	350	222
	90	355	355	353	343	385	281	342	342	338	336	369	274	328	328	322	322	351	267
10000	75	322	273	355	210	389	143	309	266	340	203	370	133	294	259	323	196	351	126
	80	330	330	357	261	389	194	318	318	341	254	372	188	304	304	324	246	354	181
	85	348	348	358	313	390	248	336	336	343	306	373	242	322	321	326	298	354	235
	90	366	366	359	359	391	298	353	353	344	344	374	290	338	338	327	327	355	283
11000	75	327	287	360	219	391	147	313	280	344	212	376	135	298	273	327	205	355	128
	80	339	339	362	273	393	202	327	327	346	266	377	195	312	312	329	258	357	188
	85	358	358	363	330	395	261	345	345	347	323	377	254	330	330	330	315	358	243
	90	376	376	363	363	395	313	362	362	348	348	378	306	347	347	330	330	359	298
12100	75	332	303	364	228	396	150	318	295	348	221	380	143	302	287	330	214	358	131
	80	348	348	366	287	397	210	335	335	350	279	380	204	320	320	332	271	361	196
	85	367	367	367	349	399	270	353	353	351	342	381	262	338	338	333	333	362	254
	90	386	386	368	368	399	331	371	371	352	352	381	323	355	354	334	334	362	315
Air Flow CFM	Ent DB (°F)	Ambient Temperature																	
		115																	
		Entering Wet Bulb Temperature																	
		61		67		73													
TGC	SHC	TGC	SHC	TGC	SHC														
8000	75	267	222	295	170	321	113												
	80	272	267	296	212	323	158												
	85	286	286	297	254	325	202												
	90	301	301	298	296	326	242												
9000	75	272	236	300	179	326	116												
	80	281	281	301	225	329	166												
	85	296	296	302	272	330	215												
	90	312	312	303	303	330	258												
10000	75	277	250	304	188	330	119												
	80	289	289	305	237	333	173												
	85	305	305	307	289	334	227												
	90	321	321	308	308	334	274												
11000	75	280	264	307	197	333	121												
	80	296	296	308	249	336	181												
	85	313	313	310	306	337	234												
	90	329	329	311	311	337	290												
12100	75	284	278	311	201	336	123												
	80	303	303	312	262	339	189												
	85	320	320	313	313	340	246												
	90	336	336	314	314	340	306												

**Notes:**

1. All capacities shown are gross and have not considered indoor fan heat. To obtain net cooling, subtract indoor fan heat.
2. TGC = Total gross capacity.
3. SHC = Sensible heat capacity.



## Performance Data (60 Hz Units)

**Table 13. 30 ton standard efficiency, gross cooling capacities (Mbh) — 1-row condenser coil — 60 Hz**

Air Flow CFM	Ent DB (°F)	Ambient Temperature																	
		85				95				105									
		Entering Wet Bulb Temperature																	
		61		67		73		61		67		73		61		67		73	
TGC	SHC	TGC	SHC	TGC	SHC	TGC	SHC	TGC	SHC	TGC	SHC	TGC	SHC	TGC	SHC	TGC	SHC		
9000	75	321	257	353	202	388	140	304	247	335	193	367	132	287	237	315	184	345	123
	80	326	304	355	247	390	189	310	294	336	237	370	180	292	284	317	227	348	171
	85	337	337	358	292	393	236	323	323	340	283	372	227	307	307	321	272	351	217
	90	356	356	364	338	394	280	341	341	346	329	374	271	324	324	327	319	353	260
10000	75	328	271	360	211	394	143	311	261	341	202	373	134	292	251	320	192	350	125
	80	334	323	361	259	397	196	317	313	343	249	376	187	299	299	323	239	354	178
	85	349	349	366	309	399	248	334	334	347	300	378	239	317	317	328	289	355	227
	90	368	368	373	361	402	296	352	352	355	351	381	286	335	335	335	335	359	276
11000	75	333	284	365	220	399	145	316	274	345	211	377	137	298	264	325	201	354	127
	80	341	341	367	271	402	203	324	324	348	261	381	194	308	308	328	251	358	185
	85	360	360	373	326	404	258	344	344	354	316	383	248	326	326	333	306	360	238
	90	380	380	379	379	408	311	363	363	363	363	387	301	345	345	345	345	364	291
12000	75	339	297	369	229	403	148	321	287	349	219	381	139	302	276	328	210	357	130
	80	348	348	373	283	407	210	332	332	353	273	385	201	315	315	332	262	362	192
	85	369	369	379	342	409	268	352	352	359	332	387	258	334	334	339	322	364	248
	90	389	389	389	389	414	326	372	372	372	372	392	316	353	353	353	353	369	306
13200	75	344	312	374	239	407	150	326	302	353	226	385	141	307	291	331	215	360	132
	80	358	358	378	297	412	218	341	341	358	286	389	209	323	323	337	275	365	200
	85	379	379	385	362	414	281	361	361	365	352	392	270	342	342	344	341	368	260
	90	400	400	400	400	419	344	382	382	382	382	397	334	362	362	362	362	374	323
Air Flow CFM	Ent DB (°F)	Ambient Temperature																	
		115																	
		Entering Wet Bulb Temperature																	
		61		67		73		61		67		73		61		67		73	
TGC	SHC	TGC	SHC	TGC	SHC	TGC	SHC	TGC	SHC	TGC	SHC	TGC	SHC	TGC	SHC	TGC	SHC		
9000	75	268	227	294	174	321	113												
	80	274	273	296	216	325	161												
	85	290	290	300	262	326	206												
	90	306	306	306	306	330	250												
10000	75	273	240	298	183	325	115												
	80	282	282	301	228	330	168												
	85	299	299	306	278	331	216												
	90	316	316	316	316	336	265												
11000	75	278	252	302	191	329	118												
	80	289	289	306	240	333	175												
	85	307	307	312	294	336	226												
	90	325	325	325	325	340	280												
12000	75	282	265	305	195	331	120												
	80	296	296	310	251	336	182												
	85	314	314	317	310	339	236												
	90	333	333	332	332	345	294												
13200	75	286	279	308	203	334	122												
	80	303	303	314	264	338	187												
	85	322	322	322	322	343	248												
	90	340	340	340	340	349	311												

**Notes:**

1. All capacities shown are gross and have not considered indoor fan heat. To obtain net cooling, subtract indoor fan heat.
2. TGC = Total gross capacity.
3. SHC = Sensible heat capacity.



## Performance Data (60 Hz Units)

**Table 14. 30 ton high efficiency - eStage, gross cooling capacities (Mbh)—1-row condenser coil—60 Hz**

Air Flow CFM	Ent DB (°F)	Ambient Temperature																	
		85						95						105					
		Entering Wet Bulb Temperature																	
		61		67		73		61		67		73		61		67		73	
TGC	SHC	TGC	SHC	TGC	SHC	TGC	SHC	TGC	SHC	TGC	SHC	TGC	SHC	TGC	SHC	TGC	SHC		
9000	75	329	262	364	204	398	144	315	255	348	198	380	134	299	247	330	190	361	127
	80	334	311	365	253	399	191	320	304	349	245	382	184	305	296	332	237	362	177
	85	346	346	366	299	400	241	334	334	350	292	383	234	320	320	333	284	363	226
	90	364	364	367	346	401	288	351	351	351	339	383	280	337	337	334	331	364	272
10000	75	335	277	370	214	404	147	321	269	354	207	386	140	305	261	336	199	366	129
	80	343	332	372	266	405	200	328	325	355	258	387	192	313	313	337	250	367	185
	85	358	358	373	318	406	253	345	345	356	310	388	247	331	331	338	302	368	239
	90	377	377	374	370	407	305	363	363	357	357	389	297	348	348	339	339	368	289
11000	75	341	291	376	223	409	151	326	284	359	216	390	145	310	275	340	209	370	132
	80	350	350	377	279	410	208	337	336	360	271	391	201	322	321	341	263	371	193
	85	369	369	378	336	411	267	355	355	361	328	392	260	340	340	342	320	372	252
	90	388	388	378	378	412	321	374	373	362	362	393	314	357	357	343	343	372	305
12000	75	346	305	378	233	414	164	331	298	363	225	394	147	313	289	344	217	374	139
	80	359	358	381	292	415	222	345	345	364	284	395	208	329	329	345	276	374	200
	85	378	378	382	354	415	280	364	364	365	346	396	268	348	348	346	337	375	260
	90	398	398	383	383	416	338	382	382	366	366	396	330	365	365	347	347	375	322
13200	75	350	322	384	241	420	155	335	314	367	235	398	151	317	305	348	224	378	143
	80	368	368	386	307	419	222	353	353	368	299	398	218	337	337	349	290	378	209
	85	388	388	387	375	419	290	373	373	369	367	399	282	356	356	349	349	378	273
	90	407	407	387	387	419	357	391	391	370	370	399	349	373	373	350	350	378	341
Air Flow CFM	Ent DB (°F)	Ambient Temperature																	
		115																	
		Entering Wet Bulb Temperature																	
		61		67		73													
TGC	SHC	TGC	SHC	TGC	SHC														
9000	75	282	238	311	182	339	119												
	80	289	287	312	228	341	169												
	85	304	304	313	275	342	218												
	90	321	320	314	314	342	263												
10000	75	287	252	316	191	344	121												
	80	297	297	317	241	345	177												
	85	314	314	318	293	346	231												
	90	330	330	319	319	347	280												
11000	75	291	266	319	200	347	124												
	80	305	305	321	254	349	184												
	85	323	323	322	311	349	239												
	90	339	339	323	323	349	296												
12000	75	294	280	323	209	351	126												
	80	312	312	325	266	352	192												
	85	330	330	325	325	352	251												
	90	346	346	326	326	352	312												
13200	75	298	296	326	214	354	129												
	80	319	319	328	281	355	201												
	85	337	336	328	328	355	264												
	90	353	352	328	328	355	332												

**Notes:**

1. All capacities shown are gross and have not considered indoor fan heat. To obtain net cooling, subtract indoor fan heat.
2. TGC = Total gross capacity.
3. SHC = Sensible heat capacity.



## Performance Data (60 Hz Units)

**Table 15. 35 ton standard efficiency, gross cooling capacities (Mbh) — 1-row condenser coil—60 Hz**

Air Flow CFM	Ent DB (°F)	Ambient Temperature																	
		85						95						105					
		Entering Wet Bulb Temperature																	
		61		67		73		61		67		73		61		67		73	
TGC	SHC	TGC	SHC	TGC	SHC	TGC	SHC	TGC	SHC	TGC	SHC	TGC	SHC	TGC	SHC	TGC	SHC		
10500	75	375	307	410	238	447	162	355	297	388	227	422	152	334	285	364	216	396	141
	80	381	364	412	293	450	221	361	353	390	282	425	210	340	340	367	269	399	200
	85	397	397	416	349	452	278	379	379	394	337	427	268	359	359	371	325	401	255
	90	417	417	422	406	454	332	399	399	401	394	430	321	378	378	378	378	404	309
12000	75	384	328	418	251	454	166	364	319	395	241	429	155	342	306	371	230	402	144
	80	392	392	421	312	458	232	373	373	398	300	433	222	353	353	374	288	406	211
	85	413	413	426	376	459	295	394	394	404	364	434	283	373	373	379	351	408	271
	90	434	434	434	434	463	357	414	414	414	414	438	345	392	392	392	392	412	333
13000	75	389	342	423	261	458	168	368	333	399	250	433	158	346	318	374	234	405	147
	80	400	400	426	324	462	240	381	381	403	313	436	229	360	360	378	300	409	218
	85	422	422	432	393	464	306	402	402	409	381	439	294	381	381	384	369	411	282
	90	444	444	444	444	468	373	423	423	423	423	443	361	400	400	400	400	416	348
14000	75	394	356	427	270	462	170	373	344	402	254	436	160	350	331	377	241	407	149
	80	408	408	430	337	466	247	388	388	407	325	440	237	367	367	382	312	411	223
	85	431	431	437	410	468	317	410	410	414	398	442	305	388	388	389	385	415	292
	90	453	453	453	453	473	389	431	431	431	431	447	377	408	408	408	408	420	364
14400	75	396	361	428	273	463	171	375	349	404	257	437	161	352	336	378	244	409	150
	80	411	411	432	341	467	250	391	391	408	329	441	239	369	369	383	317	412	225
	85	434	434	439	417	470	321	413	413	416	405	444	309	390	390	390	390	416	296
	90	456	456	456	456	475	395	434	434	434	434	449	383	410	410	410	410	421	370
Air Flow CFM	Ent DB (°F)	Ambient Temperature																	
		115																	
		Entering Wet Bulb Temperature																	
		61		67		73													
TGC	SHC	TGC	SHC	TGC	SHC														
10500	75	311	272	339	204	367	130												
	80	320	320	341	257	371	188												
	85	338	338	346	312	373	242												
	90	356	356	356	356	376	296												
12000	75	318	291	344	218	372	133												
	80	331	331	348	275	376	199												
	85	350	350	354	338	379	258												
	90	368	368	368	368	383	319												
13000	75	322	304	347	221	375	135												
	80	338	338	352	287	378	204												
	85	357	357	358	355	382	268												
	90	376	376	376	376	387	335												
14000	75	326	317	350	228	377	137												
	80	344	344	355	298	381	210												
	85	363	363	363	363	385	279												
	90	382	382	382	382	390	350												
14400	75	328	322	351	231	378	138												
	80	346	346	356	303	382	212												
	85	365	365	365	365	386	283												
	90	384	384	384	384	391	356												

**Notes:**

1. All capacities shown are gross and have not considered indoor fan heat. To obtain net cooling, subtract indoor fan heat.
2. TGC = Total gross capacity.
3. SHC = Sensible heat capacity.

## Performance Data (60 Hz Units)

**Table 16. 35 ton high efficiency - eStage, gross cooling capacities (Mbh)—1-row condenser coil—60 Hz**

Air Flow CFM	Ent DB (°F)	Ambient Temperature																	
		85						95						105					
		Entering Wet Bulb Temperature																	
		61		67		73		61		67		73		61		67		73	
TGC	SHC	TGC	SHC	TGC	SHC	TGC	SHC	TGC	SHC	TGC	SHC	TGC	SHC	TGC	SHC	TGC	SHC		
10500	75	371	302	409	234	446	162	356	294	392	227	427	155	339	286	372	219	406	144
	80	378	361	410	291	447	218	363	354	393	283	428	211	344	344	373	274	407	203
	85	394	394	412	346	449	276	380	380	394	338	429	269	364	364	375	329	408	261
	90	414	414	413	401	449	331	399	399	395	393	430	323	383	383	376	376	409	315
12000	75	380	324	417	249	454	163	364	316	399	241	0	0	346	307	379	232	412	147
	80	388	388	419	310	455	231	375	375	400	302	434	223	359	359	381	293	413	215
	85	410	410	420	373	456	296	395	395	401	365	436	289	378	378	382	356	414	281
	90	431	431	421	421	456	357	415	415	402	402	436	349	397	397	382	382	414	340
13000	75	385	338	420	257	458	180	368	330	403	250	437	165	350	321	383	241	416	155
	80	398	398	423	323	459	245	383	383	404	315	438	231	366	366	384	306	417	222
	85	419	419	424	391	460	309	403	403	405	383	439	302	386	386	385	374	417	289
	90	440	440	425	425	460	373	423	423	406	406	440	365	405	405	386	386	418	356
14000	75	388	352	425	265	462	186	372	344	406	259	440	167	353	335	386	250	419	155
	80	406	406	427	336	463	254	390	390	408	327	441	239	373	373	387	319	420	227
	85	427	427	428	409	463	322	411	411	409	400	443	309	393	393	388	388	420	300
	90	448	448	428	428	464	390	431	431	409	409	443	382	412	412	389	389	420	373
14400	75	390	358	425	271	463	188	373	350	408	259	443	164	355	340	387	253	419	160
	80	409	408	428	341	464	257	393	393	409	332	443	239	376	376	388	324	420	234
	85	430	430	429	416	464	327	414	414	410	408	444	313	396	396	389	389	421	305
	90	451	451	429	429	465	397	434	434	410	410	444	388	415	415	390	390	421	379
Air Flow CFM	Ent DB (°F)	Ambient Temperature																	
		115																	
		Entering Wet Bulb Temperature																	
		61		67		73													
TGC	SHC	TGC	SHC	TGC	SHC														
10500	75	319	276	351	210	382	135												
	80	328	328	352	264	383	194												
	85	346	346	353	319	384	252												
	90	365	364	354	354	385	305												
12000	75	326	297	357	223	388	139												
	80	341	341	358	283	389	206												
	85	360	360	359	346	390	272												
	90	378	378	360	360	390	330												
13000	75	329	311	360	232	391	141												
	80	348	347	362	296	392	214												
	85	367	366	362	362	393	279												
	90	385	385	363	363	393	347												
14000	75	332	325	363	241	393	144												
	80	354	354	364	308	394	222												
	85	373	373	365	365	395	290												
	90	391	391	366	366	395	363												
14400	75	333	330	364	239	394	145												
	80	356	356	365	313	394	225												
	85	375	375	366	366	396	294												
	90	393	393	367	367	396	370												

**Notes:**

1. All capacities shown are gross and have not considered indoor fan heat. To obtain net cooling, subtract indoor fan heat.
2. TGC = Total gross capacity.
3. SHC = Sensible heat capacity.



**Performance Data (60 Hz Units)**

**Table 17. 40 ton standard efficiency, gross cooling capacities (Mbh)—2-row condenser coil—60 Hz**

Air Flow CFM	Ent DB (°F)	Ambient Temperature																	
		85						95						105					
		Entering Wet Bulb Temperature																	
		61		67		73		61		67		73		61		67		73	
TGC	SHC	TGC	SHC	TGC	SHC	TGC	SHC	TGC	SHC	TGC	SHC	TGC	SHC	TGC	SHC	TGC	SHC		
12000	75	433	344	479	267	527	181	407	328	450	250	495	165	379	310	420	233	462	148
	80	440	411	481	331	530	249	414	393	453	313	499	232	387	375	423	295	465	215
	85	457	457	486	395	533	315	433	433	458	378	501	298	407	407	428	359	468	281
	90	483	483	493	461	535	379	458	458	465	443	504	361	431	431	435	425	471	342
14000	75	447	374	492	287	539	187	420	356	462	270	506	170	391	337	430	252	471	153
	80	453	453	495	357	543	265	429	429	465	339	510	248	403	403	434	321	475	230
	85	481	481	501	432	545	340	455	455	471	414	512	322	428	428	440	395	478	303
	90	508	508	508	508	549	412	482	482	481	481	516	394	453	453	453	453	482	375
15000	75	453	388	497	296	544	190	425	370	466	279	510	173	396	351	434	262	475	155
	80	463	463	500	370	548	273	438	438	470	352	514	255	411	411	439	333	479	238
	85	491	491	507	450	550	351	465	465	477	431	517	333	437	437	446	412	482	314
	90	519	519	520	518	555	428	492	492	491	491	522	410	462	462	462	462	487	391
16000	75	458	402	501	306	548	192	430	384	471	289	514	175	401	365	438	271	478	158
	80	472	472	505	383	552	280	446	446	475	364	518	263	419	419	443	345	481	245
	85	501	501	513	467	555	362	474	474	483	449	521	344	445	445	451	429	486	324
	90	529	529	529	529	560	444	501	501	500	500	526	426	471	471	470	470	491	406
17600	75	466	424	508	321	554	196	437	405	476	298	519	179	408	386	443	279	483	162
	80	485	485	513	402	558	292	458	458	482	384	522	274	429	429	449	364	486	255
	85	514	514	521	495	561	380	486	486	491	476	527	361	456	456	456	456	491	341
	90	543	543	543	543	567	469	514	514	513	513	533	451	482	482	482	482	497	431
Air Flow CFM	Ent DB (°F)	Ambient Temperature																	
		115																	
		Entering Wet Bulb Temperature																	
		61		67		73		61		67		73							
TGC	SHC	TGC	SHC	TGC	SHC	TGC	SHC	TGC	SHC	TGC	SHC								
12000	75	350	291	388	215	426	130												
	80	357	357	391	276	430	197												
	85	380	380	396	340	432	261												
	90	403	403	403	403	436	323												
14000	75	361	318	397	234	434	135												
	80	375	375	401	301	439	212												
	85	399	399	407	375	441	283												
	90	423	423	423	423	446	355												
15000	75	366	332	400	239	438	137												
	80	382	382	405	313	440	219												
	85	407	407	412	392	445	294												
	90	431	431	431	431	450	371												
16000	75	370	345	403	246	441	140												
	80	389	389	409	325	444	225												
	85	414	414	417	409	449	304												
	90	439	439	438	438	454	386												
17600	75	376	366	408	259	445	144												
	80	399	399	414	344	449	234												
	85	424	424	424	424	454	321												
	90	449	449	449	449	460	410												

**Notes:**  
**1.** All capacities shown are gross and have not considered indoor fan heat. To obtain net cooling, subtract indoor fan heat.  
**2.** TGC = Total gross capacity.  
**3.** SHC = Sensible heat capacity.

## Performance Data (60 Hz Units)

**Table 18. 40 ton high efficiency - eStage, gross cooling capacities (Mbh)—2-row condenser coil—60 Hz**

Air Flow CFM	Ent DB (°F)	Ambient Temperature																	
		85						95						105					
		Entering Wet Bulb Temperature																	
		61		67		73		61		67		73		61		67		73	
TGC	SHC	TGC	SHC	TGC	SHC	TGC	SHC	TGC	SHC	TGC	SHC	TGC	SHC	TGC	SHC	TGC	SHC		
12000	75	445	358	495	278	550	193	425	348	475	267	526	184	403	337	450	257	498	174
	80	453	427	496	344	550	259	433	417	474	334	526	250	412	406	450	323	499	240
	85	472	472	499	410	550	325	455	455	477	399	526	316	436	436	453	389	500	306
	90	499	499	501	475	550	391	0	0	479	465	526	382	462	462	455	454	501	372
14000	75	458	390	510	319	560	200	437	380	487	303	535	186	414	368	462	275	507	177
	80	470	470	511	384	561	276	452	452	488	363	536	265	433	433	463	352	509	256
	85	499	499	512	449	562	351	480	480	490	438	537	342	459	459	464	427	510	332
	90	526	526	514	514	562	427	499	538	491	491	538	416	486	486	466	466	511	406
15000	75	464	406	515	365	565	204	442	395	492	324	516	193	419	384	466	285	512	186
	80	481	481	517	416	565	284	462	462	493	377	541	274	442	442	467	366	513	266
	85	510	510	518	468	566	364	490	490	494	458	542	355	469	469	469	446	514	345
	90	537	537	519	519	567	445	513	545	496	496	579	437	496	496	470	470	515	424
16000	75	469	421	520	413	569	209	447	410	496	346	516	195	423	399	470	294	515	188
	80	491	491	521	449	569	293	471	471	497	391	545	283	450	450	471	379	517	273
	85	520	520	522	486	570	377	500	500	499	476	545	368	478	478	473	465	518	357
	90	547	547	523	523	571	462	526	550	500	500	588	458	504	504	474	474	519	442
17600	75	475	445	526	490	574	216	453	434	502	502	516	201	428	422	475	308	521	193
	80	504	504	527	503	575	307	484	484	503	503	549	298	462	462	477	401	522	285
	85	533	533	528	516	576	398	516	534	504	504	551	387	490	490	478	478	522	377
	90	561	561	529	529	576	489	547	585	505	505	598	488	522	526	479	479	523	468
Air Flow CFM	Ent DB (°F)	Ambient Temperature																	
		115																	
		Entering Wet Bulb Temperature																	
		61		67		73		61		67		73		61		67		73	
TGC	SHC	TGC	SHC	TGC	SHC	TGC	SHC	TGC	SHC	TGC	SHC	TGC	SHC	TGC	SHC	TGC	SHC		
12000	75	379	325	424	246	469	163												
	80	391	391	426	312	470	229												
	85	402	456	427	378	472	295												
	90	413	521	429	429	473	360												
14000	75	390	356	434	264	478	168												
	80	411	411	436	340	480	245												
	85	433	466	437	416	481	322												
	90	462	462	438	438	482	395												
15000	75	394	372	438	273	481	169												
	80	420	420	440	354	483	252												
	85	446	468	441	434	486	335												
	90	471	471	442	442	485	413												
16000	75	397	387	442	282	484	172												
	80	428	428	443	368	487	260												
	85	458	468	445	453	489	348												
	90	480	480	446	446	489	430												
17600	75	402	402	446	296	490	180												
	80	438	438	448	389	491	272												
	85	475	475	450	481	492	365												
	90	511	511	451	451	493	457												

**Notes:**

1. All capacities shown are gross and have not considered indoor fan heat. To obtain net cooling, subtract indoor fan heat.
2. TGC = Total gross capacity.
3. SHC = Sensible heat capacity.



**Performance Data (60 Hz Units)**

**Table 19. 50 ton standard efficiency, gross cooling capacities (MBh)—2-row condenser coil—60 Hz**

Air Flow CFM	Ent DB (°F)	Ambient Temperature																	
		85						95						105					
		Entering Wet Bulb Temperature																	
		61		67		73		61		67		73		61		67		73	
TGC	SHC	TGC	SHC	TGC	SHC	TGC	SHC	TGC	SHC	TGC	SHC	TGC	SHC	TGC	SHC	TGC	SHC		
15000	75	538	438	593	339	650	232	508	421	559	322	612	215	476	402	523	304	572	197
	80	547	522	596	420	654	317	518	504	562	402	617	300	484	484	526	382	577	282
	85	571	571	602	501	657	400	543	543	569	483	620	383	514	514	533	463	579	363
	90	603	603	611	584	660	479	574	574	578	565	623	461	543	543	542	542	584	441
17000	75	552	468	605	359	661	237	520	449	570	341	622	220	487	429	532	323	581	202
	80	562	562	609	446	666	333	534	534	574	428	627	316	503	503	537	408	586	298
	85	595	595	616	538	668	424	565	565	582	519	630	405	534	534	545	499	589	386
	90	627	627	627	627	674	513	597	597	596	596	636	494	564	564	563	563	595	474
18000	75	557	482	610	368	666	240	526	463	574	350	626	222	492	444	536	332	584	205
	80	571	571	614	459	671	341	542	542	579	441	632	323	511	511	542	421	590	305
	85	605	605	622	556	673	435	575	575	588	537	635	416	542	542	551	517	594	397
	90	638	638	638	638	680	529	607	607	606	606	641	510	573	573	572	572	600	490
19000	75	563	496	614	377	670	242	531	477	578	360	630	225	496	457	540	341	587	207
	80	580	580	619	472	675	348	551	551	584	453	636	330	519	519	546	433	591	312
	85	614	614	628	574	678	447	583	583	593	554	639	428	550	550	556	534	598	408
	90	648	648	648	648	685	546	616	616	616	616	646	526	581	581	581	581	605	506
20000	75	568	510	618	387	674	245	535	491	582	369	633	227	501	471	542	344	591	209
	80	589	589	624	485	679	355	558	558	588	465	639	338	526	526	550	445	597	320
	85	623	623	634	591	683	458	592	592	598	572	643	439	558	558	561	551	601	419
	90	657	657	657	657	690	562	624	624	624	624	651	542	589	589	588	588	609	522
Air Flow CFM	Ent DB (°F)	Ambient Temperature																	
		115																	
		Entering Wet Bulb Temperature																	
		61		67		73													
TGC	SHC	TGC	SHC	TGC	SHC														
15000	75	441	382	485	286	529	179												
	80	454	454	488	362	535	263												
	85	482	482	495	443	537	342												
	90	509	509	509	509	542	421												
17000	75	451	409	493	304	537	184												
	80	470	470	498	387	543	279												
	85	499	499	506	478	546	365												
	90	528	528	528	528	552	453												
18000	75	456	423	496	313	540	186												
	80	478	478	502	400	544	285												
	85	507	507	511	495	550	376												
	90	536	536	536	536	557	469												
19000	75	460	436	499	315	543	189												
	80	485	485	506	412	547	291												
	85	514	514	514	514	553	386												
	90	544	544	543	543	561	485												
20000	75	464	450	502	323	545	191												
	80	491	491	509	424	550	297												
	85	521	521	521	521	557	397												
	90	550	550	550	550	564	500												

**Notes:**

1. All capacities shown are gross and have not considered indoor fan heat. To obtain net cooling, subtract indoor fan heat.
2. TGC = Total gross capacity.
3. SHC = Sensible heat capacity.

## Performance Data (60 Hz Units)

**Table 20. 50 ton high efficiency - eStage, gross cooling capacities (MBh)—2-row condenser coil—60 Hz**

Air Flow CFM	Ent DB (°F)	Ambient Temperature																	
		85						95						105					
		Entering Wet Bulb Temperature																	
		61		67		73		61		67		73		61		67		73	
TGC	SHC	TGC	SHC	TGC	SHC	TGC	SHC	TGC	SHC	TGC	SHC	TGC	SHC	TGC	SHC	TGC	SHC		
15000	75	539	443	596	340	652	231	516	431	570	329	624	221	491	418	850	433	594	210
	80	551	530	597	424	653	316	528	518	572	412	626	305	503	503	784	458	596	294
	85	576	576	600	505	655	400	555	555	574	493	628	390	533	533	547	481	598	378
	90	606	606	601	586	656	481	585	585	576	575	629	470	562	562	549	549	599	458
17000	75	551	473	607	359	661	241	527	461	581	348	634	226	501	448	987	518	602	215
	80	567	567	609	451	662	332	545	545	583	439	636	321	621	578	845	501	605	310
	85	598	598	611	542	665	426	577	577	585	530	637	415	553	553	556	517	606	402
	90	629	629	612	612	666	515	639	639	586	586	638	504	582	582	558	558	608	491
18000	75	556	488	612	368	666	244	532	476	585	357	610	231	505	462	556	345	606	217
	80	576	576	614	464	667	340	554	554	587	452	640	329	632	590	878	524	609	318
	85	608	608	616	560	669	437	586	586	589	548	641	426	562	562	561	536	610	413
	90	639	639	617	617	670	531	655	655	591	591	685	524	591	591	562	562	611	508
19000	75	561	503	616	377	670	247	536	490	589	366	610	231	509	477	560	354	609	219
	80	585	585	618	477	671	347	563	563	592	465	643	337	643	602	911	546	612	325
	85	617	617	620	579	673	449	595	595	593	567	644	437	570	570	564	554	613	425
	90	648	648	621	621	674	548	669	669	595	595	695	545	599	599	566	566	614	524
20000	75	565	517	619	385	674	251	539	504	593	375	608	232	512	491	563	363	612	222
	80	593	593	622	490	674	355	570	570	595	478	645	345	653	613	1001	611	615	333
	85	625	625	624	597	676	460	602	602	597	585	648	449	577	577	567	567	616	436
	90	656	656	625	625	677	564	682	682	598	598	703	565	606	606	569	569	617	540
Air Flow CFM	Ent DB (°F)	Ambient Temperature																	
		115																	
		Entering Wet Bulb Temperature																	
		61		67		73		61		67		73		61		67		73	
TGC	SHC	TGC	SHC	TGC	SHC	TGC	SHC	TGC	SHC	TGC	SHC	TGC	SHC	TGC	SHC	TGC	SHC		
15000	75	464	405	512	305	560	198												
	80	480	480	514	386	563	282												
	85	508	508	517	467	564	365												
	90	536	536	518	518	566	444												
17000	75	473	434	521	323	568	203												
	80	497	497	524	412	571	298												
	85	527	527	526	504	573	388												
	90	555	555	527	527	574	478												
18000	75	476	448	525	333	571	205												
	80	505	505	527	425	575	306												
	85	535	535	529	522	576	400												
	90	563	563	531	531	577	494												
19000	75	480	462	527	338	574	207												
	80	512	512	531	438	578	313												
	85	542	542	533	533	579	411												
	90	570	570	534	534	580	510												
20000	75	483	476	530	346	577	210												
	80	518	518	534	451	580	321												
	85	549	549	535	535	582	422												
	90	576	576	537	537	582	527												

**Notes:**

1. All capacities shown are gross and have not considered indoor fan heat. To obtain net cooling, subtract indoor fan heat.
2. TGC = Total gross capacity.
3. SHC = Sensible heat capacity.



## Performance Data (60 Hz Units)

**Table 21. Electric heat air temperature rise—60 Hz**

KW Input	Total MBH	CFM												
		8000	9000	10000	11000	12000	13000	14000	15000	16000	17000	18000	19000	20000
36	123	14.2	12.6	11.3	10.3	9.4	8.7	8.1	7.6	—	—	—	—	—
54	184	21.2	18.9	17.0	15.4	14.2	13.1	12.1	11.3	10.6	10.0	9.4	8.9	8.5
72	246	28.3	25.2	22.6	20.6	18.9	17.4	16.2	15.1	14.2	13.3	12.6	11.9	11.3
90	307	35.4	31.5	28.3	25.7	23.6	21.8	20.2	18.9	17.7	16.7	15.7	14.9	14.2
108	369	—	—	—	—	28.3	26.1	24.3	22.6	21.2	20.0	18.9	17.9	17.0

**Table 22. Available electric heat KW ranges—60 Hz**

Nominal Unit Size Tons	Electric Heat Rated Voltage			
	208	240	480	600
27½	27-41	36-54	36-90	54-90
30.0	27-41	36-54	36-90	54-90
35.0	27-41	36-54	36-90	54-90
40.0	41	54	54-108	54-108
50.0	41	54	54-108	54-108

**Notes:**

1. kW ranges in this table are based on heater operating at 208, 240, 480, and 600 volts.
2. For other than rated voltage, kW = (Applied Voltage/Rate Voltage)<sup>2</sup> x Rated kW.
3. Electric heaters up to 54 kW are single element heaters, those above 54 kW are dual element heaters.

**Table 23. Gas input/output ranges—60 Hz**

Tonnage	Heat option	Two-Stage		Modulating		Air Temp. Rise (°F)
		Input <sup>(a)</sup> (MBh)	Output <sup>(a)</sup> (MBh)	Input Range (MBh)	Output Range (MBh)	
27.5 - 35	Low	350/250	280/200	140-350	112-280	10-40
	High	600/425	480/340	120-600	96-480	25-55
40-50	Low	400/300	320/240	140-350	112-280	5-35
	High	800/600	640/480	150-750	120-600	20-50

(a) Second stage / first stage



Figure 5. Supply fan performance—27½-35 ton—60 Hz

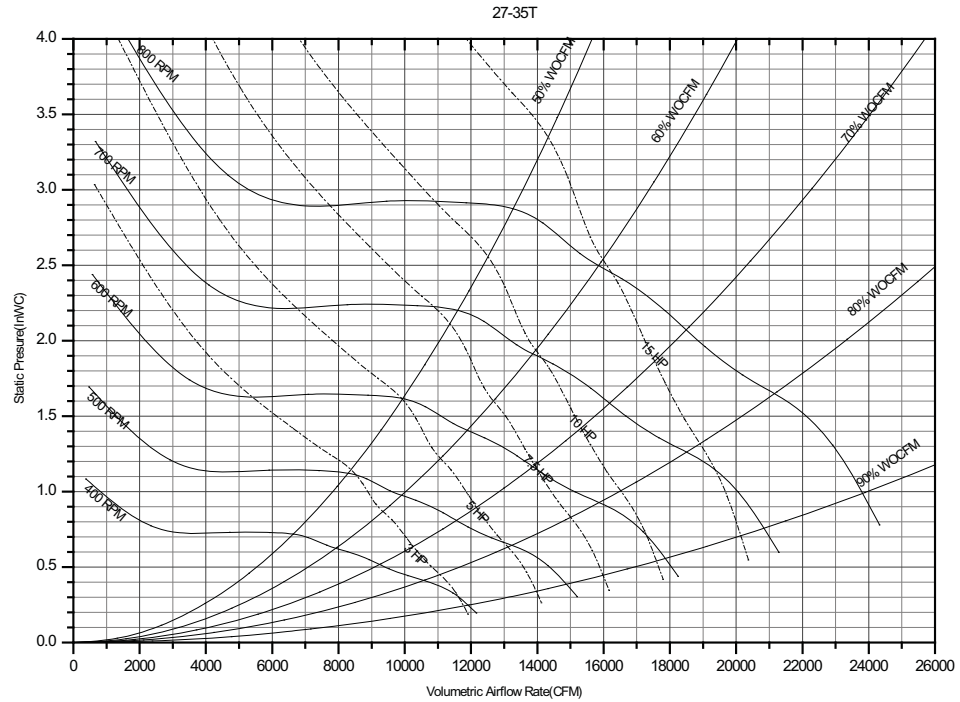
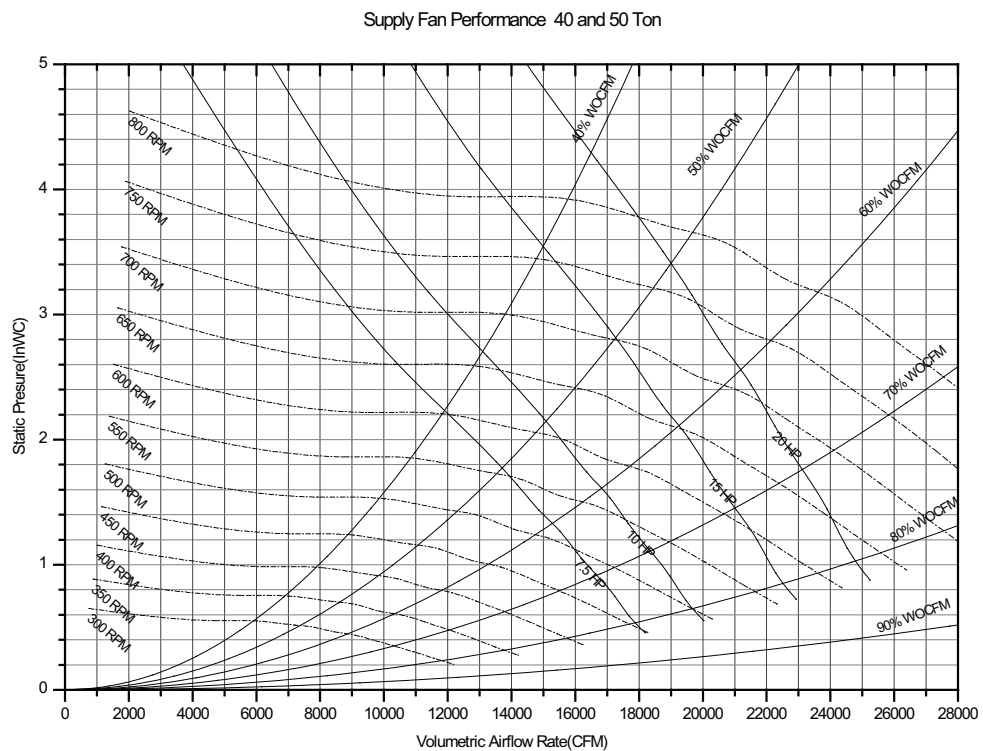


Figure 6. Supply fan performance — 40 and 50 ton—60 Hz





## Performance Data (60 Hz Units)

**Table 24. Component static pressure drops (in. W.G.)<sup>1</sup> – 60 Hz**

Nominal Tons	CFM Std Air	Heating System				Standard Efficiency ID Coil		High Efficiency ID Coil		Filters <sup>2</sup>				Economizer	Hot Gas Reheat Coil
		Gas Heat		Electric Heat <sup>3</sup>		Dry	Wet	Dry	Wet	Throw-away	MERV 8 High Eff.		MERV 14 High Eff.		
		Low	High	1 Element	2 Elements						2"	2"	4"		
27½	8000	0.08	0.06	0.05	0.06	0.12	0.19	0.16	0.25	0.08	0.12	0.11	0.33	0.04	0.08
	9000	0.1	0.08	0.07	0.07	0.14	0.22	0.19	0.29	0.09	0.14	0.13	0.39	0.04	0.10
	10000	0.13	0.1	0.08	0.09	0.17	0.26	0.23	0.34	0.1	0.16	0.15	0.45	0.05	0.12
	11000	0.15	0.12	0.1	0.11	0.20	0.30	0.27	0.39	0.12	0.2	0.17	0.52	0.06	0.14
	12000	0.18	0.14	0.12	0.13	0.23	0.34	0.31	0.45	0.13	0.21	0.2	0.59	0.07	0.17
30	9000	0.1	0.08	0.07	0.07	0.14	0.22	0.19	0.29	0.09	0.14	0.13	0.39	0.04	0.10
	10000	0.13	0.1	0.08	0.09	0.17	0.26	0.23	0.34	0.1	0.16	0.15	0.45	0.05	0.12
	11000	0.15	0.12	0.1	0.11	0.20	0.30	0.27	0.39	0.12	0.2	0.17	0.52	0.06	0.14
	12000	0.18	0.14	0.12	0.13	0.23	0.34	0.31	0.45	0.14	0.23	0.21	0.59	0.07	0.17
	13000	0.21	0.16	0.14	0.15	0.27	0.38	0.35	0.50	0.15	0.26	0.23	0.66	0.09	0.20
35	10500	0.14	0.11	0.09	0.1	0.25	0.37	0.25	0.37	0.11	0.18	0.16	0.48	0.06	0.13
	11500	0.17	0.13	0.11	0.12	0.29	0.42	0.29	0.42	0.13	0.21	0.19	0.55	0.07	0.16
	12500	0.2	0.15	0.13	0.14	0.33	0.48	0.33	0.48	0.14	0.24	0.21	0.62	0.08	0.18
	13500	0.23	0.18	0.15	0.16	0.38	0.53	0.38	0.53	0.15	0.26	0.23	0.70	0.1	0.22
	14500	0.26	0.2	0.18	0.19	0.42	0.59	0.42	0.59	0.17	0.3	0.27	0.77	0.11	0.25
40	12000	0.01	0.03	0.08	0.13	0.24	0.36	0.30	0.45	0.1	0.19	0.17	0.48	0.07	0.06
	13000	0.01	0.04	0.1	0.15	0.28	0.41	0.35	0.51	0.12	0.23	0.2	0.53	0.08	0.07
	14000	0.02	0.05	0.11	0.18	0.31	0.46	0.39	0.57	0.13	0.25	0.22	0.59	0.09	0.08
	15000	0.02	0.05	0.13	0.2	0.35	0.50	0.44	0.63	0.14	0.28	0.24	0.66	0.1	0.09
	16000	0.02	0.06	0.15	0.23	0.39	0.55	0.49	0.69	0.15	0.31	0.27	0.72	0.11	0.10
17000	0.02	0.07	0.17	0.26	0.43	0.60	0.54	0.75	0.17	0.35	0.3	0.79	0.12	0.11	
50	15000	0.02	0.05	0.13	0.2	0.44	0.63	0.44	0.63	0.14	0.28	0.24	0.66	0.1	0.09
	16000	0.02	0.06	0.15	0.23	0.49	0.69	0.49	0.69	0.15	0.31	0.27	0.72	0.11	0.10
	17000	0.02	0.07	0.17	0.26	0.54	0.75	0.54	0.75	0.17	0.35	0.3	0.79	0.12	0.11
	18000	0.03	0.08	0.19	0.29	0.59	0.82	0.59	0.82	0.18	0.38	0.33	0.85	0.14	0.13
	19000	0.03	0.08	0.21	0.32	0.65	0.89	0.65	0.89	0.19	0.42	0.35	0.92	0.16	0.14
20000	0.03	0.09	0.23	0.36	0.71	0.96	0.71	0.96	0.2	0.45	0.38	0.99	0.18	0.16	

**Notes:**

1. Static pressure drops of accessory components must be added to external static pressure to enter fan selection tables.
2. Throwaway filter option limited to 300 ft/min face velocity.
3. Electric Heaters 36-54 KW contain 1 element; 72-108 KW 2 elements.

## Performance Data (60 Hz Units)

**Table 25. Supply air fan drive selections—60 Hz**

Nominal Tons	7.5 HP		10 HP		15 HP		20 HP	
	RPM	Drive No.	RPM	Drive No.	RPM	Drive No.	RPM	Drive No.
27½	550	A						
	600	B						
	650	C						
			700	D				
				750 <sup>1</sup>	E			
30	550	A						
	600	B						
	650	C						
			700	D				
			750	E	750	E		
					790 <sup>2</sup>	F		
				800 <sup>1</sup>	G			
35	600	B						
			650	C				
			700	D				
			750	E	750	E		
					790 <sup>2</sup>	F		
					800 <sup>1</sup>	G		
40			500	H				
			525	J				
			575	K				
					625	L		
					675	M		
					725	N		
50			525	J				
			575	K				
					625	L		
					675	M	675	M
						725	N	

**Notes:**

1. For YC gas heat units only.
2. For TC/TE Cooling only and electric heat units only.



**Performance Data (60 Hz Units)**

**Table 26. Power exhaust fan performance—27.5-35 ton—60 Hz**

	Power Exhaust Selection			
	50%		100%	
	Damper Open Position			
	min	max	min	max
Return Duct Static (in. wc)	CFM			
0.0	3812	6866	7624	13742
0.1	3497	5296	6995	10591
0.2	3190	4458	6325	9000
0.3	2884	3812	5768	7635
0.4	2621	3359	5241	6719
0.5	2342	2885	4683	5771

**Table 27. Power exhaust fan performance—40-50—60 Hz**

	Power Exhaust Selection			
	50%		100%	
	Damper Open Position			
	min	max	min	max
Return Duct Static (in. wc)	CFM			
0.0	4854	8035	9708	16069
0.1	4575	7410	9151	14820
0.2	4262	6450	8552	13496
0.3	4011	6027	8021	12054
0.4	3718	5526	7436	11051
0.5	3467	5186	6933	10373

**Note:** These values are the minimum and maximum positions for non-tracking power exhaust. Fresh air tracking and Statitrac options can fully close the exhaust dampers in their operation, and are thus able to reach lower airflows. Statitrac requires 100% power exhaust.



# Performance Data (50 Hz Units)

**Table 28. 22.9 ton standard efficiency, gross cooling capacities (MBh)—1-row condenser coil (I-P)—50 Hz**

CFM	Ent DB °F	Ambient Temperature (°F)																	
		85						95						105					
		Entering Wet Bulb Temperature (°F)																	
		61		67		73		61		67		73		61		67		73	
TGC	SHC	TGC	SHC	TGC	SHC	TGC	SHC	TGC	SHC	TGC	SHC	TGC	SHC	TGC	SHC	TGC	SHC		
6900	75	246	194	272	152	299	106	232	185	256	144	281	97.4	217	176	240	136	262	88.9
	80	250	230	273	187	301	143	236	221	258	178	284	134	221	212	241	169	265	126
	85	258	258	276	222	303	179	245	245	260	213	286	171	232	232	244	203	268	162
	90	272	272	280	257	304	213	259	259	264	248	287	204	245	245	248	239	269	195
7500	75	250	202	276	158	302	107	236	194	260	150	284	99	221	184	243	141	265	90.4
	80	255	241	277	194	305	147	241	232	262	185	288	139	226	223	245	176	269	130
	85	265	265	281	232	308	186	252	252	265	223	290	178	238	238	248	213	270	167
	90	280	280	285	270	309	222	267	267	270	261	292	213	252	252	253	252	273	204
8000	75	254	209	279	163	305	109	239	200	263	154	287	100	224	191	245	146	267	91.6
	80	259	251	281	200	309	151	244	242	265	191	290	143	229	229	247	182	271	134
	85	271	271	284	240	311	193	258	258	268	231	292	182	243	243	251	222	273	172
	90	287	287	290	281	313	230	273	273	274	272	295	221	257	257	257	257	276	211
9000	75	259	222	284	172	310	111	244	213	267	163	291	103	228	203	249	155	271	93.9
	80	265	265	286	212	314	158	252	252	270	203	295	150	237	237	252	193	275	141
	85	281	281	291	257	316	202	267	267	274	248	297	193	252	252	257	238	278	183
	90	298	298	297	297	319	245	283	283	283	283	301	236	267	267	267	267	281	226
10000	75	264	235	288	181	314	113	249	226	270	168	294	105	233	216	252	158	274	96.1
	80	273	273	291	224	318	165	259	259	274	214	299	157	244	244	256	204	277	146
	85	290	290	296	273	320	212	275	275	280	264	301	203	259	259	262	253	281	192
	90	307	307	307	307	324	260	291	291	291	291	306	251	275	275	275	275	286	241

CFM	Ent DB °F	Ambient Temperature (°F)					
		115					
		Entering Wet Bulb Temperature (°F)					
		61		67		73	
TGC	SHC	TGC	SHC	TGC	SHC		
6900	75	201	167	222	127	242	80.1
	80	206	202	224	159	246	117
	85	217	217	227	193	247	151
	90	230	230	231	229	250	185
7500	75	205	174	225	132	245	81.5
	80	210	210	227	166	248	121
	85	223	223	230	203	250	157
	90	236	236	236	236	253	194
8000	75	207	181	227	137	247	82.7
	80	214	214	229	172	250	125
	85	227	227	233	211	252	162
	90	241	241	241	241	256	201
9000	75	212	193	230	141	250	84.9
	80	221	221	233	183	254	132
	85	235	235	238	227	256	172
	90	249	249	249	249	260	216
10000	75	215	205	233	148	252	87.1
	80	227	227	237	193	255	135
	85	242	242	243	242	260	182
	90	256	256	256	256	264	230

**Notes:**  
1. All capacities shown are gross and have not considered indoor fan heat. To obtain net cooling, subtract indoor fan heat.  
2. TGC = Total gross capacity.  
3. SHC = Sensible heat capacity.



**Performance Data (50 Hz Units)**

**Table 29. 22.9 ton high efficiency - eStage, gross cooling capacities (MBh)—1-row condenser coil (I-P)—50 Hz**

CFM	Ent DB °F	Ambient Temperature (°F)																	
		85						95						105					
		Entering Wet Bulb Temperature (°F)																	
		61		67		73		61		67		73		61		67		73	
TGC	SHC	TGC	SHC	TGC	SHC	TGC	SHC	TGC	SHC	TGC	SHC	TGC	SHC	TGC	SHC	TGC	SHC		
6900	75	256	202	285	159	314	111	245	197	273	153	299	105	233	190	259	147	283	100
	80	260	240	286	196	315	149	250	234	274	190	301	144	237	228	259	184	285	138
	85	269	269	287	232	314	188	260	260	275	226	302	182	249	249	261	220	286	176
	90	284	284	288	268	317	224	274	274	276	263	303	218	263	263	262	256	287	212
7500	75	261	212	290	165	318	113	250	206	277	159	303	107	236	199	262	153	287	101
	80	265	252	291	204	320	154	255	247	278	199	305	149	242	240	263	192	289	143
	85	278	278	292	244	320	196	268	268	279	237	305	189	256	256	265	231	289	183
	90	293	293	293	283	321	235	282	282	280	277	306	228	270	270	266	266	290	222
8000	75	264	219	293	169	321	114	253	213	279	164	306	109	239	207	264	158	289	102
	80	270	263	294	211	323	158	259	258	281	205	308	153	247	247	266	198	291	147
	85	284	284	295	253	323	202	273	273	282	247	308	197	262	262	267	240	292	191
	90	299	299	296	295	324	243	288	288	283	283	309	237	276	276	268	268	293	230
9000	75	269	233	298	179	326	117	258	228	284	173	310	111	244	221	269	167	292	105
	80	278	278	299	224	328	167	268	268	286	218	312	161	256	256	271	211	295	155
	85	295	295	301	271	329	214	283	283	287	265	313	207	271	271	272	258	296	201
	90	311	311	301	301	329	260	299	299	288	288	313	254	285	285	272	272	296	247
10000	75	274	248	302	188	330	119	262	242	288	182	314	114	248	235	272	173	295	107
	80	287	287	304	237	330	175	276	276	289	231	316	169	263	263	274	224	298	163
	85	304	304	305	289	333	226	292	292	291	283	317	219	278	278	275	275	299	211
	90	320	320	306	306	333	277	307	307	291	291	317	270	293	293	275	275	299	263

CFM	Ent DB °F	Ambient Temperature (°F)					
		115					
		Entering Wet Bulb Temperature (°F)					
		61		67		73	
TGC	SHC	TGC	SHC	TGC	SHC		
6900	75	219	183	243	141	266	93
	80	224	221	243	176	268	132
	85	236	236	246	213	269	169
	90	250	250	247	247	269	204
7500	75	223	192	245	146	269	95
	80	230	230	246	184	271	136
	85	243	243	249	224	271	178
	90	257	257	250	250	272	215
8000	75	225	199	247	151	270	96
	80	234	234	250	191	273	140
	85	248	248	251	233	274	181
	90	261	261	252	252	274	223
9000	75	229	213	252	161	273	98
	80	241	241	254	204	276	148
	85	256	256	255	251	277	193
	90	270	270	255	255	277	239
10000	75	233	227	255	165	276	101
	80	249	249	257	216	279	156
	85	263	263	258	258	280	204
	90	276	276	258	258	280	255

**Notes:**  
1. All capacities shown are gross and have not considered indoor fan heat. To obtain net cooling, subtract indoor fan heat.  
2. TGC = Total gross capacity.  
3. SHC = Sensible heat capacity.

## Performance Data (50 Hz Units)

**Table 30. 82 kW (22.9 ton) standard efficiency, gross cooling capacities—1-row condenser coil (SI)—50 Hz**

L/s		Ent DB °C		Ambient Temperature (°C)															
				29.4				35.0				40.6							
				Entering Wet Bulb Temperature (°C)															
				16.1		19.4		22.8		16.1		19.4		22.8		16.1		19.4	
TGC	SHC	TGC	SHC	TGC	SHC	TGC	SHC	TGC	SHC	TGC	SHC	TGC	SHC	TGC	SHC	TGC	SHC	TGC	SHC
3260	23.9	72.1	56.8	79.7	44.5	87.6	31.1	68.0	54.2	75.0	42.2	82.3	28.5	63.6	51.6	70.3	39.8	76.8	26.0
	26.7	73.2	67.4	80.0	54.8	88.2	41.9	69.1	64.8	75.6	52.2	83.2	39.3	64.8	62.1	70.6	49.5	77.6	36.9
	29.4	75.6	75.6	80.9	65.0	88.8	52.4	71.8	71.8	76.2	62.4	83.8	50.1	68.0	68.0	71.5	59.5	78.5	47.5
	32.2	79.7	79.7	82.0	75.3	89.1	62.4	75.9	75.9	77.4	72.7	84.1	59.8	71.8	71.8	72.7	70.0	78.8	57.1
3540	23.9	73.2	59.2	80.9	46.3	88.5	31.4	69.1	56.8	76.2	43.9	83.2	29.0	64.8	53.9	71.2	41.3	77.6	26.5
	26.7	74.7	70.6	81.2	56.8	89.4	43.1	70.6	68.0	76.8	54.2	84.4	40.7	66.2	65.3	71.8	51.6	78.8	38.1
	29.4	77.6	77.6	82.3	68.0	90.2	54.5	73.8	73.8	77.6	65.3	85.0	52.2	69.7	69.7	72.7	62.4	79.1	48.9
	32.2	82.0	82.0	83.5	79.1	90.5	65.0	78.2	78.2	79.1	76.5	85.6	62.4	73.8	73.8	74.1	73.8	80.0	59.8
3780	23.9	74.4	61.2	81.7	47.8	89.4	31.9	70.0	58.6	77.1	45.1	84.1	29.3	65.6	56.0	71.8	42.8	78.2	26.8
	26.7	75.9	73.5	82.3	58.6	90.5	44.2	71.5	70.9	77.6	56.0	85.0	41.9	67.1	67.1	72.4	53.3	79.4	39.3
	29.4	79.4	79.4	83.2	70.3	91.1	56.5	75.6	75.6	78.5	67.7	85.6	53.3	71.2	71.2	73.5	65.0	80.0	50.4
	32.2	84.1	84.1	85.0	82.3	91.7	67.4	80.0	80.0	80.3	79.7	86.4	64.8	75.3	75.3	75.3	75.3	80.9	61.8
4250	23.9	75.9	65.0	83.2	50.4	90.8	32.5	71.5	62.4	78.2	47.8	85.3	30.2	66.8	59.5	73.0	45.4	79.4	27.5
	26.7	77.6	77.6	83.8	62.1	92.0	46.3	73.8	73.8	79.1	59.5	86.4	43.9	69.4	69.4	73.8	56.5	80.6	41.3
	29.4	82.3	82.3	85.3	75.3	92.6	59.2	78.2	78.2	80.3	72.7	87.0	56.5	73.8	73.8	75.3	69.7	81.5	53.6
	32.2	87.3	87.3	87.0	87.0	93.5	71.8	82.9	82.9	82.9	82.9	88.2	69.1	78.2	78.2	78.2	78.2	82.3	66.2
4720	23.9	77.4	68.9	84.4	53.0	92.0	33.1	73.0	66.2	79.1	49.2	86.1	30.8	68.3	63.3	73.8	46.3	80.3	28.2
	26.7	80.0	80.0	85.3	65.6	93.2	48.3	75.9	75.9	80.3	62.7	87.6	46.0	71.5	71.5	75.0	59.8	81.2	42.8
	29.4	85.0	85.0	86.7	80.0	93.8	62.1	80.6	80.6	82.0	77.4	88.2	59.5	75.9	75.9	76.8	74.1	82.3	56.3
	32.2	90.0	90.0	90.0	90.0	94.9	76.2	85.3	85.3	85.3	85.3	89.7	73.5	80.6	80.6	80.6	80.6	83.8	70.6
L/s		Ent DB °C		Ambient Temperature (°C)															
				46.1															
				Entering Wet Bulb Temperature (°C)															
				16.1		19.4		22.8											
TGC	SHC	TGC	SHC	TGC	SHC														
3260	23.9	58.9	48.9	65.0	37.2	70.9	23.5												
	26.7	60.4	59.2	65.6	46.6	72.1	34.3												
	29.4	63.6	63.6	66.5	56.5	72.4	44.2												
	32.2	67.4	67.4	67.7	67.1	73.2	54.2												
3540	23.9	60.1	51.0	65.9	38.7	71.8	23.9												
	26.7	61.5	61.5	66.5	48.6	72.7	35.5												
	29.4	65.3	65.3	67.4	59.5	73.2	46.0												
	32.2	69.1	69.1	69.1	69.1	74.1	56.8												
3780	23.9	60.7	53.0	66.5	40.1	72.4	24.2												
	26.7	62.7	62.7	67.1	50.4	73.2	36.6												
	29.4	66.5	66.5	68.3	61.8	73.8	47.5												
	32.2	70.6	70.6	70.6	70.6	75.0	58.9												
4250	23.9	62.1	56.5	67.4	41.3	73.2	24.9												
	26.7	64.8	64.8	68.3	53.6	74.4	38.7												
	29.4	68.9	68.9	69.7	66.5	75.0	50.4												
	32.2	73.0	73.0	73.0	73.0	76.2	63.3												
4720	23.9	63.0	60.1	68.3	43.4	73.8	25.5												
	26.7	66.5	66.5	69.4	56.5	74.7	39.6												
	29.4	70.9	70.9	71.2	70.9	76.2	53.3												
	32.2	75.0	75.0	75.0	75.0	77.4	67.4												

- Notes:**
1. All capacities shown are gross and have not considered indoor fan heat. To obtain net cooling, subtract indoor fan heat.
  2. TGC = Total gross capacity.
  3. SHC = Sensible heat capacity.



Performance Data (50 Hz Units)

Table 31. 82 kW (22.9 ton) high efficiency - eStage, gross cooling capacities— 1-row condenser coil (SI)—50 Hz

L/s		Ent DB °C		Ambient Temperature (°C)																	
				29.4				35.0				40.6									
				Entering Wet Bulb Temperature (°C)																	
				16.1		19.4		22.8		16.1		19.4		22.8		16.1		19.4		22.8	
TGC SHC		TGC SHC		TGC SHC		TGC SHC		TGC SHC		TGC SHC		TGC SHC		TGC SHC		TGC SHC					
3260	23.9	74.9	59.2	83.5	46.5	92.0	32.5	71.8	57.6	79.9	44.9	87.6	30.9	68.2	55.7	75.8	43.2	83.1	29.2		
	26.7	76.2	70.2	83.8	57.4	92.4	43.8	73.3	68.7	80.2	55.8	88.2	42.2	69.6	66.8	76.0	53.8	83.6	40.4		
	29.4	78.9	78.9	84.3	68.1	92.2	55.0	76.2	76.2	80.6	66.3	88.4	53.4	72.9	72.9	76.4	64.4	83.8	51.5		
	32.2	83.3	83.3	84.5	78.7	92.9	65.7	80.4	80.4	80.8	77.0	88.7	63.9	77.0	77.0	76.8	75.1	84.1	62.0		
3540	23.9	76.4	62.0	84.8	48.3	93.2	33.0	73.2	60.4	81.0	46.6	88.7	31.4	69.3	58.4	76.8	44.8	84.0	29.7		
	26.7	77.8	74.0	85.2	59.9	93.7	45.2	74.7	72.4	81.4	58.2	89.3	43.6	71.1	70.5	77.1	56.2	84.6	41.9		
	29.4	81.4	81.4	85.6	71.4	93.8	57.3	78.4	78.4	81.7	69.6	89.5	55.5	75.0	75.0	77.6	67.7	84.8	53.6		
	32.2	85.9	85.8	85.8	82.9	94.2	68.7	82.7	82.7	82.0	81.2	89.8	66.9	79.2	79.2	77.8	77.8	85.1	65.0		
3780	23.9	77.3	64.1	85.7	49.6	94.1	33.4	74.0	62.5	81.9	48.0	89.6	31.8	70.2	60.5	77.5	46.2	84.6	30.0		
	26.7	79.1	77.1	86.2	61.9	94.5	46.4	75.9	75.5	82.3	60.1	90.1	44.8	72.3	72.3	77.9	58.1	85.3	43.1		
	29.4	83.2	83.1	86.5	74.1	94.8	59.1	80.2	80.1	82.6	72.3	90.4	57.8	76.7	76.6	78.3	70.4	85.5	56.0		
	32.2	87.8	87.7	86.8	86.4	95.0	71.2	84.5	84.5	82.8	82.8	90.6	69.4	80.8	80.7	78.5	78.5	85.7	67.5		
4250	23.9	78.9	68.4	87.4	52.4	95.6	34.2	75.7	66.8	83.3	50.8	90.9	32.6	71.5	64.7	78.8	49.0	85.7	30.8		
	26.7	81.6	81.5	87.8	65.7	96.1	48.8	78.5	78.5	83.7	63.9	91.5	47.2	74.9	74.9	79.3	61.9	86.5	45.4		
	29.4	86.4	86.4	88.1	79.5	96.3	62.6	83.0	82.9	84.0	77.7	91.7	60.7	79.4	79.4	79.6	75.7	86.7	58.8		
	32.2	91.1	91.0	88.3	88.3	96.4	76.2	87.5	87.5	84.3	84.3	91.9	74.3	83.5	83.5	79.7	79.7	86.8	72.3		
4720	23.9	80.3	72.6	88.6	55.1	96.7	35.0	76.7	70.8	84.4	53.5	91.9	33.3	72.6	68.8	79.8	50.6	86.6	31.5		
	26.7	84.2	84.2	89.1	69.5	96.8	51.3	80.9	80.9	84.8	67.6	92.6	49.5	77.1	77.1	80.3	65.6	87.5	47.7		
	29.4	89.1	89.1	89.3	84.8	97.5	66.1	85.6	85.6	85.2	82.9	92.8	64.0	81.5	81.5	80.6	80.6	87.7	62.0		
	32.2	93.8	93.8	89.5	89.5	97.6	81.1	90.0	90.0	85.4	85.4	92.9	79.2	85.8	85.8	80.7	80.7	87.7	77.1		
L/s		Ent DB °C		Ambient Temperature (°C)																	
				46.1				Entering Wet Bulb Temperature (°C)													
				16.1		19.4		22.8													
				TGC SHC		TGC SHC		TGC SHC													
3260	23.9	64.3	53.8	71.2	41.3	77.9	27.3														
	26.7	65.8	64.8	71.2	51.6	78.5	38.5														
	29.4	69.2	69.2	72.0	62.4	78.7	49.4														
	32.2	73.3	73.3	72.3	72.3	79.0	59.9														
3540	23.9	65.3	56.3	71.8	42.8	78.7	27.8														
	26.7	67.3	67.3	72.1	54.0	79.3	40.0														
	29.4	71.2	71.2	72.9	65.6	79.6	52.1														
	32.2	75.2	75.2	73.2	73.2	79.8	62.9														
3780	23.9	66.0	58.4	72.4	44.2	79.2	28.1														
	26.7	68.5	68.5	73.3	56.0	80.0	41.1														
	29.4	72.8	72.7	73.6	68.3	80.2	53.2														
	32.2	76.6	76.6	73.8	73.8	80.4	65.4														
4250	23.9	67.2	62.5	73.9	47.0	80.1	28.9														
	26.7	70.7	70.7	74.4	59.7	81.0	43.5														
	29.4	75.1	75.1	74.7	73.5	81.2	56.4														
	32.2	79.1	79.0	74.9	74.9	81.3	70.1														
4720	23.9	68.2	66.6	74.9	48.3	80.9	29.6														
	26.7	73.0	73.0	75.3	63.3	81.9	45.8														
	29.4	77.1	77.1	75.5	75.5	82.0	59.9														
	32.2	81.0	81.0	75.7	75.7	82.0	74.9														

Notes:

1. All capacities shown are gross and have not considered indoor fan heat. To obtain net cooling, subtract indoor fan heat.
2. TGC = Total gross capacity.
3. SHC = Sensible heat capacity.



## Performance Data (50 Hz Units)

**Table 32. 25.4 ton standard efficiency, gross cooling capacities (MBh)—1-row condenser coil (I-P)—50 Hz**

CFM	Ent DB °F	Ambient Temperature (°F)																	
		85						95						105					
		Entering Wet Bulb Temperature (°F)																	
		61		67		73		61		67		73		61		67		73	
TGC	SHC	TGC	SHC	TGC	SHC	TGC	SHC	TGC	SHC	TGC	SHC	TGC	SHC	TGC	SHC	TGC	SHC		
7500	75	267	214	295	168	324	117	253	206	279	160	306	109	237	196	261	152	286	101
	80	272	253	297	206	327	158	257	245	281	197	309	150	242	236	263	188	290	141
	85	282	282	300	244	329	197	269	269	284	235	311	189	255	255	267	226	292	181
	90	297	297	304	283	330	234	284	284	288	274	313	226	269	269	272	265	294	217
8000	75	271	221	299	173	328	118	256	213	282	165	309	111	240	203	264	156	289	102
	80	276	263	300	212	331	162	261	254	284	204	312	153	246	245	266	194	292	145
	85	288	288	304	253	333	203	275	275	288	244	314	195	260	260	270	235	294	185
	90	304	304	309	294	334	242	290	290	293	286	316	234	275	275	275	275	297	224
9000	75	278	235	304	182	333	121	262	226	287	174	314	113	246	217	269	165	293	105
	80	284	282	307	225	336	169	269	269	290	216	317	161	254	254	272	206	297	152
	85	299	299	311	270	338	214	285	285	294	261	319	205	270	270	276	252	299	196
	90	316	316	318	317	341	258	301	301	301	301	323	249	285	285	285	285	303	240
10000	75	283	248	309	191	337	123	267	239	291	182	317	115	250	229	272	170	296	107
	80	292	292	312	236	341	176	277	277	295	227	322	168	262	262	276	218	301	159
	85	309	309	317	287	343	224	294	294	300	278	324	215	278	278	281	268	303	206
	90	327	327	326	326	347	273	311	311	311	311	328	264	294	294	294	294	308	255
11000	75	288	261	313	199	341	126	272	252	294	187	321	117	255	242	275	177	299	109
	80	299	299	317	248	345	183	284	284	299	239	325	175	268	268	280	229	302	164
	85	317	317	322	303	348	235	302	302	305	294	328	226	285	285	286	284	307	216
	90	336	336	335	335	352	288	319	319	319	319	333	279	302	302	302	302	312	269
CFM	Ent DB °F	Ambient Temperature (°F)																	
		115																	
		Entering Wet Bulb Temperature (°F)																	
		61		67		73		61		67		73		61		67		73	
TGC	SHC	TGC	SHC	TGC	SHC	TGC	SHC	TGC	SHC	TGC	SHC	TGC	SHC	TGC	SHC	TGC	SHC		
7500	75	220	187	243	143	265	92												
	80	225	225	245	179	269	133												
	85	239	239	248	217	270	170												
	90	253	253	253	253	273	207												
8000	75	223	194	245	147	267	94												
	80	230	230	247	185	271	136												
	85	244	244	251	225	273	175												
	90	259	259	259	259	276	215												
9000	75	228	207	249	156	271	96												
	80	238	238	252	196	275	143												
	85	253	253	257	241	278	186												
	90	268	268	268	268	281	230												
10000	75	233	219	252	160	274	98												
	80	245	245	256	208	277	148												
	85	260	260	262	258	281	196												
	90	276	276	276	276	286	244												
11000	75	236	231	255	167	276	100												
	80	251	251	260	219	280	153												
	85	267	267	267	267	285	205												
	90	283	283	283	283	289	259												

**Notes:**

1. All capacities shown are gross and have not considered indoor fan heat. To obtain net cooling, subtract indoor fan heat.
2. TGC = Total gross capacity.
3. SHC = Sensible heat capacity.



**Performance Data (50 Hz Units)**

**Table 33. 25.4 ton high efficiency - eStage, gross cooling capacities (MBh) – 1-row condenser coil (I-P) – 50 Hz**

CFM	Ent DB °F	Ambient Temperature (°F)																	
		85						95						105					
		Entering Wet Bulb Temperature (°F)																	
		61		67		73		61		67		73		61		67		73	
TGC	SHC	TGC	SHC	TGC	SHC	TGC	SHC	TGC	SHC	TGC	SHC	TGC	SHC	TGC	SHC	TGC	SHC		
7500	75	273	217	303	169	333	117	261	211	289	163	317	111	247	204	274	156	300	104
	80	277	258	304	210	334	158	266	252	290	203	318	152	252	245	275	196	301	146
	85	288	288	305	249	333	200	277	277	291	242	319	194	265	265	276	235	302	187
	90	303	303	306	288	335	239	292	292	292	282	319	233	279	279	277	274	302	226
8000	75	277	225	306	174	336	118	265	218	292	168	320	112	250	211	277	161	303	106
	80	282	269	307	217	337	163	270	262	293	210	321	156	256	256	278	203	304	150
	85	294	294	308	258	337	207	283	283	294	251	322	201	271	271	279	244	304	194
	90	310	310	309	300	338	248	298	298	295	294	322	241	285	285	279	279	305	234
9000	75	282	239	312	184	341	121	270	233	297	177	325	115	255	225	281	171	307	108
	80	289	289	313	230	342	171	278	278	299	223	325	165	265	265	282	216	308	158
	85	306	306	314	277	343	219	294	294	299	270	326	214	280	280	283	262	309	207
	90	322	322	315	315	343	265	309	309	300	300	327	258	295	295	284	284	309	251
10000	75	287	254	317	193	346	123	274	247	302	186	329	117	259	239	285	180	310	111
	80	299	299	318	243	346	179	286	286	303	236	330	172	273	273	286	229	312	166
	85	316	316	319	295	347	233	303	303	304	288	330	223	289	289	287	280	312	216
	90	332	332	319	319	347	282	318	318	304	304	331	275	303	303	288	288	312	267
11000	75	292	268	321	202	339	152	278	261	305	195	332	120	262	253	288	185	314	113
	80	307	307	322	256	350	186	294	294	306	249	333	180	280	280	289	241	315	174
	85	324	324	322	313	351	242	310	310	307	306	333	235	295	295	290	290	315	227
	90	340	340	323	323	350	298	326	326	307	307	333	291	310	310	290	290	315	284
CFM	Ent DB °F	Ambient Temperature (°F)																	
		115																	
		Entering Wet Bulb Temperature (°F)																	
		61		67		73		61		67		73		61		67		73	
TGC	SHC	TGC	SHC	TGC	SHC	TGC	SHC	TGC	SHC	TGC	SHC	TGC	SHC	TGC	SHC	TGC	SHC		
7500	75	232	196	257	149	281	97												
	80	238	237	258	188	283	139												
	85	252	252	259	227	283	180												
	90	265	265	260	260	284	218												
8000	75	235	203	260	154	284	99												
	80	241	241	261	195	285	143												
	85	257	257	262	237	286	187												
	90	271	270	263	263	286	226												
9000	75	239	217	264	163	288	101												
	80	251	251	265	208	289	151												
	85	266	266	266	255	289	196												
	90	279	279	267	267	290	243												
10000	75	242	231	267	170	291	104												
	80	258	258	268	220	292	159												
	85	273	273	269	269	292	208												
	90	287	287	270	270	292	259												
11000	75	245	244	270	177	293	106												
	80	265	264	271	233	295	166												
	85	279	279	272	272	295	219												
	90	293	293	272	272	295	276												

**Notes:**  
1. All capacities shown are gross and have not considered indoor fan heat. To obtain net cooling, subtract indoor fan heat.  
2. TGC = Total gross capacity.  
3. SHC = Sensible heat capacity.

### Performance Data (50 Hz Units)

**Table 34. 89 kw (25.4 ton) standard efficiency, gross cooling capacities—1-row condenser coil (SI)—50 Hz**

L/s	Ent DB °C	Ambient Temperature (°C)																	
		29.4						35.0						40.6					
		Entering Wet Bulb Temperature (°C)																	
		16.1		19.4		22.8		16.1		19.4		22.8		16.1		19.4		22.8	
TGC	SHC	TGC	SHC	TGC	SHC	TGC	SHC	TGC	SHC	TGC	SHC	TGC	SHC	TGC	SHC	TGC	SHC		
3540	23.9	78.2	62.7	86.4	49.2	94.9	34.3	74.1	60.4	81.7	46.9	89.7	31.9	69.4	57.4	76.5	44.5	83.8	29.6
	26.7	79.7	74.1	87.0	60.4	95.8	46.3	75.3	71.8	82.3	57.7	90.5	43.9	70.9	69.1	77.1	55.1	85.0	41.3
	29.4	82.6	82.6	87.9	71.5	96.4	57.7	78.8	78.8	83.2	68.9	91.1	55.4	74.7	74.7	78.2	66.2	85.6	53.0
	32.2	87.0	87.0	89.1	82.9	96.7	68.6	83.2	83.2	84.4	80.3	91.7	66.2	78.8	78.8	79.7	77.6	86.1	63.6
3780	23.9	79.4	64.8	87.6	50.7	96.1	34.6	75.0	62.4	82.6	48.3	90.5	32.5	70.3	59.5	77.4	45.7	84.7	29.9
	26.7	80.9	77.1	87.9	62.1	97.0	47.5	76.5	74.4	83.2	59.8	91.4	44.8	72.1	71.8	77.9	56.8	85.6	42.5
	29.4	84.4	84.4	89.1	74.1	97.6	59.5	80.6	80.6	84.4	71.5	92.0	57.1	76.2	76.2	79.1	68.9	86.1	54.2
	32.2	89.1	89.1	90.5	86.1	97.9	70.9	85.0	85.0	85.8	83.8	92.6	68.6	80.6	80.6	80.6	80.6	87.0	65.6
4250	23.9	81.5	68.9	89.1	53.3	97.6	35.5	76.8	66.2	84.1	51.0	92.0	33.1	72.1	63.6	78.8	48.3	85.8	30.8
	26.7	83.2	82.6	90.0	65.9	98.4	49.5	78.8	78.8	85.0	63.3	92.9	47.2	74.4	74.4	79.7	60.4	87.0	44.5
	29.4	87.6	87.6	91.1	79.1	99.0	62.7	83.5	83.5	86.1	76.5	93.5	60.1	79.1	79.1	80.9	73.8	87.6	57.4
	32.2	92.6	92.6	93.2	92.9	99.9	75.6	88.2	88.2	88.2	88.2	94.6	73.0	83.5	83.5	83.5	83.5	88.8	70.3
4720	23.9	82.9	72.7	90.5	56.0	98.7	36.0	78.2	70.0	85.3	53.3	92.9	33.7	73.2	67.1	79.7	49.8	86.7	31.4
	26.7	85.6	85.6	91.4	69.1	99.9	51.6	81.2	81.2	86.4	66.5	94.3	49.2	76.8	76.8	80.9	63.9	88.2	46.6
	29.4	90.5	90.5	92.9	84.1	100.5	65.6	86.1	86.1	87.9	81.5	94.9	63.0	81.5	81.5	82.3	78.5	88.8	60.4
	32.2	95.8	95.8	95.5	95.5	101.7	80.0	91.1	91.1	91.1	91.1	96.1	77.4	86.1	86.1	86.1	86.1	90.2	74.7
5190	23.9	84.4	76.5	91.7	58.3	99.9	36.9	79.7	73.8	86.1	54.8	94.1	34.3	74.7	70.9	80.6	51.9	87.6	31.9
	26.7	87.6	87.6	92.9	72.7	101.1	53.6	83.2	83.2	87.6	70.0	95.2	51.3	78.5	78.5	82.0	67.1	88.5	48.1
	29.4	92.9	92.9	94.3	88.8	102.0	68.9	88.5	88.5	89.4	86.1	96.1	66.2	83.5	83.5	83.8	83.2	90.0	63.3
	32.2	98.4	98.4	98.2	98.2	103.1	84.4	93.5	93.5	93.5	93.5	97.6	81.7	88.5	88.5	88.5	88.5	91.4	78.8
L/s	Ent DB °C	Ambient Temperature (°C)																	
		46.1																	
		Entering Wet Bulb Temperature (°C)																	
		16.1		19.4		22.8		16.1		19.4		22.8		16.1		19.4		22.8	
TGC	SHC	TGC	SHC	TGC	SHC	TGC	SHC	TGC	SHC	TGC	SHC	TGC	SHC	TGC	SHC	TGC	SHC		
3540	23.9	64.5	54.8	71.2	41.9	77.6	27.1												
	26.7	65.9	65.9	71.8	52.4	78.8	39.0												
	29.4	70.0	70.0	72.7	63.6	79.1	49.8												
	32.2	74.1	74.1	74.1	74.1	80.0	60.7												
3780	23.9	65.3	56.8	71.8	43.1	78.2	27.4												
	26.7	67.4	67.4	72.4	54.2	79.4	39.8												
	29.4	71.5	71.5	73.5	65.9	80.0	51.3												
	32.2	75.9	75.9	75.9	75.9	80.9	63.0												
4250	23.9	66.8	60.7	73.0	45.7	79.4	28.1												
	26.7	69.7	69.7	73.8	57.4	80.6	41.9												
	29.4	74.1	74.1	75.3	70.6	81.5	54.5												
	32.2	78.5	78.5	78.5	78.5	82.3	67.4												
4720	23.9	68.3	64.2	73.8	46.9	80.3	28.7												
	26.7	71.8	71.8	75.0	60.9	81.2	43.4												
	29.4	76.2	76.2	76.8	75.6	82.3	57.4												
	32.2	80.9	80.9	80.9	80.9	83.8	71.5												
5190	23.9	69.1	67.7	74.7	48.9	80.9	29.3												
	26.7	73.5	73.5	76.2	64.2	82.0	44.8												
	29.4	78.2	78.2	78.2	78.2	83.5	60.1												
	32.2	82.9	82.9	82.9	82.9	84.7	75.9												

**Notes:**  
 1. All capacities shown are gross and have not considered indoor fan heat. To obtain net cooling, subtract indoor fan heat.  
 2. TGC = Total gross capacity.  
 3. SHC = Sensible heat capacity.



## Performance Data (50 Hz Units)

**Table 35. 89 kw (25.4 ton) high efficiency - eStage, gross cooling capacities—1-row condenser coil (SI)—50 Hz**

L/s	Ent DB °C	Ambient Temperature (°C)																	
		29.4						35.0						40.6					
		Entering Wet Bulb Temperature (°C)																	
		16.1		19.4		22.8		16.1		19.4		22.8		16.1		19.4		22.8	
TGC	SHC	TGC	SHC	TGC	SHC	TGC	SHC	TGC	SHC	TGC	SHC	TGC	SHC	TGC	SHC	TGC	SHC		
3540	23.9	79.9	63.6	88.8	49.6	97.5	34.2	76.5	61.8	84.6	47.8	92.9	32.4	72.4	59.7	80.2	45.8	87.9	30.6
	26.7	81.3	75.6	89.0	61.5	97.7	46.4	77.9	73.8	84.9	59.5	93.2	44.6	73.9	71.7	80.6	57.5	88.2	42.7
	29.4	84.3	84.3	89.4	72.9	97.6	58.7	81.1	81.1	85.2	70.9	93.4	56.8	77.6	77.6	80.9	68.9	88.5	54.9
	32.2	88.8	88.8	89.7	84.5	98.2	70.1	85.5	85.5	85.6	82.5	93.6	68.2	81.9	81.9	81.1	80.4	88.6	66.1
3780	23.9	81.1	65.9	89.8	51.0	98.4	34.6	77.5	64.0	85.6	49.2	93.7	32.8	73.3	61.8	81.1	47.2	88.7	31.0
	26.7	82.7	78.8	90.1	63.5	98.7	47.6	79.1	76.9	85.8	61.5	94.1	45.8	74.9	74.9	81.4	59.4	89.0	43.9
	29.4	86.2	86.2	90.4	75.6	98.6	60.7	82.9	82.9	86.2	73.7	94.2	58.8	79.3	79.3	81.7	71.6	89.2	56.9
	32.2	90.9	90.8	90.6	88.0	99.1	72.7	87.4	87.4	86.5	86.0	94.5	70.7	83.5	83.5	81.9	81.9	89.4	68.6
4250	23.9	82.8	70.1	91.5	53.8	100.0	35.4	79.0	68.2	87.1	51.9	95.2	33.6	74.8	66.1	82.5	50.0	90.0	31.7
	26.7	84.8	84.8	91.8	67.4	100.3	50.0	81.4	81.3	87.5	65.4	95.2	48.3	77.7	77.7	82.7	63.2	90.3	46.3
	29.4	89.6	89.6	92.1	81.1	100.4	64.1	86.1	86.1	87.8	79.1	95.6	62.6	82.2	82.2	83.0	76.9	90.4	60.7
	32.2	94.3	94.3	92.3	92.3	100.6	77.6	90.6	90.6	88.0	88.0	95.8	75.7	86.5	86.5	83.2	83.2	90.6	73.5
4720	23.9	84.2	74.4	92.8	56.5	101.3	36.2	80.3	72.4	88.4	54.7	96.4	34.4	75.9	70.2	83.6	52.7	91.0	32.4
	26.7	87.6	87.6	93.1	71.2	101.4	52.5	83.9	83.9	88.7	69.2	96.6	50.5	80.0	80.0	83.9	67.0	91.3	48.6
	29.4	92.5	92.5	93.4	86.4	101.7	68.3	88.7	88.7	89.0	84.4	96.8	65.4	84.6	84.6	84.1	82.2	91.5	63.3
	32.2	97.2	97.2	93.6	93.6	101.8	82.5	93.3	93.3	89.1	89.1	96.9	80.6	88.9	88.9	84.3	84.3	91.5	78.4
5190	23.9	85.5	78.6	94.0	59.2	99.4	44.4	81.4	76.5	89.4	57.2	97.4	35.1	76.8	74.2	84.5	54.3	91.9	33.2
	26.7	89.9	89.9	94.3	74.9	102.6	54.6	86.1	86.1	89.7	72.8	97.6	52.8	82.0	82.0	84.8	70.7	92.2	50.9
	29.4	94.9	94.9	94.5	91.7	102.7	70.8	90.9	90.9	89.9	89.6	97.7	68.7	86.6	86.6	85.0	85.0	92.3	66.6
	32.2	99.7	99.7	94.6	94.6	102.7	87.4	95.5	95.5	90.1	90.1	97.7	85.4	90.9	90.9	85.1	85.1	92.2	83.2
L/s	Ent DB °C	Ambient Temperature (°C)																	
		46.1																	
		Entering Wet Bulb Temperature (°C)																	
		16.1		19.4		22.8		16.1		19.4		22.8		16.1		19.4		22.8	
TGC	SHC	TGC	SHC	TGC	SHC	TGC	SHC	TGC	SHC	TGC	SHC	TGC	SHC	TGC	SHC	TGC	SHC		
3540	23.9	68.1	57.5	75.4	43.8	82.5	28.5												
	26.7	69.7	69.5	75.7	55.2	82.8	40.7												
	29.4	73.8	73.7	76.0	66.7	83.0	52.8												
	32.2	77.8	77.7	76.3	76.3	83.2	63.9												
3780	23.9	68.9	59.6	76.1	45.2	83.2	28.9												
	26.7	70.7	70.7	76.5	57.1	83.5	41.9												
	29.4	75.3	75.3	76.8	69.3	83.7	54.8												
	32.2	79.3	79.3	77.0	77.0	83.9	66.3												
4250	23.9	70.1	63.7	77.4	47.9	84.3	29.7												
	26.7	73.6	73.6	77.7	60.9	84.6	44.2												
	29.4	77.9	77.8	77.9	74.6	84.8	57.6												
	32.2	81.9	81.9	78.1	78.1	84.9	71.2												
4720	23.9	70.9	67.7	78.4	49.7	85.3	30.4												
	26.7	75.7	75.7	78.7	64.6	85.6	46.5												
	29.4	80.0	80.0	78.9	78.9	85.7	60.9												
	32.2	84.0	84.0	79.0	79.0	85.7	76.0												
5190	23.9	71.7	71.7	79.2	51.8	86.0	31.1												
	26.7	77.5	77.5	79.5	68.3	86.4	48.8												
	29.4	81.8	81.8	79.6	79.6	86.4	64.2												
	32.2	85.8	85.8	79.7	79.7	86.3	80.8												

**Notes:**

1. All capacities shown are gross and have not considered indoor fan heat. To obtain net cooling, subtract indoor fan heat.
2. TGC = Total gross capacity.
3. SHC = Sensible heat capacity.

## Performance Data (50 Hz Units)

**Table 36. 29.2 ton standard efficiency, gross cooling capacities (MBh)—1-row condenser coil (IP)—50 Hz**

CFM	Ent DB °F	Ambient Temperature (°F)																	
		85						95						105					
		Entering Wet Bulb Temperature (°F)																	
		61		67		73		61		67		73		61		67		73	
TGC	SHC	TGC	SHC	TGC	SHC	TGC	SHC	TGC	SHC	TGC	SHC	TGC	SHC	TGC	SHC	TGC	SHC		
8750	75	314	256	344	198	376	136	296	247	325	189	355	127	278	236	305	179	332	117
	80	319	305	346	245	379	185	302	295	327	235	357	176	283	283	307	224	335	166
	85	332	332	349	292	380	233	317	317	331	282	359	223	300	300	311	271	336	212
	90	350	350	354	339	382	278	334	334	336	329	361	268	316	316	316	316	339	258
9000	75	315	260	346	201	377	136	298	250	327	191	356	127	280	240	306	182	333	118
	80	321	310	348	248	380	187	304	300	329	238	359	178	286	286	308	228	336	168
	85	335	335	351	296	382	237	319	319	332	286	360	226	303	303	312	276	338	215
	90	353	353	356	345	384	282	337	337	338	335	363	272	319	319	319	319	341	262
10000	75	322	274	351	210	383	139	304	265	332	201	360	130	285	254	310	191	337	120
	80	328	328	354	261	386	195	312	312	334	251	364	185	295	295	313	240	341	176
	85	347	347	358	314	387	247	330	330	338	304	365	237	312	312	318	293	342	226
	90	365	365	365	365	390	299	348	348	347	347	369	289	329	329	329	329	346	278
11000	75	327	289	356	219	387	141	309	280	336	210	364	132	290	269	314	196	340	123
	80	337	337	359	274	390	202	320	320	339	263	368	193	302	302	318	252	344	184
	85	356	356	364	332	392	258	339	339	344	322	370	248	320	320	323	311	346	237
	90	375	375	375	375	396	315	357	357	357	357	373	305	337	337	337	337	350	294
12000	75	332	302	359	225	390	144	313	292	339	214	367	134	294	281	317	203	343	125
	80	345	345	363	286	394	210	328	328	343	276	370	199	309	309	321	264	346	188
	85	365	365	369	350	396	269	346	346	349	339	374	259	327	327	328	328	350	248
	90	384	384	384	384	400	331	365	365	365	365	378	321	344	344	344	344	354	309
CFM	Ent DB °F	Ambient Temperature (°F)																	
		115																	
		Entering Wet Bulb Temperature (°F)																	
		61		67		73		61		67		73		61		67		73	
TGC	SHC	TGC	SHC	TGC	SHC	TGC	SHC	TGC	SHC	TGC	SHC	TGC	SHC	TGC	SHC	TGC	SHC		
8750	75	259	225	283	169	308	107												
	80	266	266	285	213	311	156												
	85	282	282	289	260	313	201												
	90	297	297	297	297	315	246												
9000	75	260	229	284	172	309	108												
	80	268	268	287	216	312	158												
	85	284	284	291	264	314	204												
	90	300	300	300	300	317	250												
10000	75	265	243	288	181	312	110												
	80	276	276	291	229	316	166												
	85	293	293	296	282	318	215												
	90	308	308	308	308	321	266												
11000	75	269	257	291	184	315	113												
	80	283	283	295	241	319	173												
	85	300	300	301	299	321	225												
	90	316	316	316	316	325	282												
12000	75	273	271	294	191	317	115												
	80	289	289	298	252	321	176												
	85	306	306	306	306	324	236												
	90	322	322	322	322	329	297												

**Notes:**

1. All capacities shown are gross and have not considered indoor fan heat. To obtain net cooling, subtract indoor fan heat.
2. TGC = Total gross capacity.
3. SHC = Sensible heat capacity.



**Performance Data (50 Hz Units)**

**Table 37. 29.2 ton high efficiency - eStage, gross cooling capacities (MBh)—1-row condenser coil (IP)—50 Hz**

CFM	Ent DB °F	Ambient Temperature (°F)																	
		85						95						105					
		Entering Wet Bulb Temperature (°F)																	
		61		67		73		61		67		73		61		67		73	
TGC	SHC	TGC	SHC	TGC	SHC	TGC	SHC	TGC	SHC	TGC	SHC	TGC	SHC	TGC	SHC	TGC	SHC		
8750	75	308	253	339	194	370	131	294	246	324	188	354	125	279	238	308	181	335	118
	80	314	304	340	242	371	180	301	297	325	235	355	174	286	286	309	227	336	167
	85	328	328	341	289	372	229	316	316	327	281	356	222	302	302	310	274	338	215
	90	345	345	342	336	373	274	332	332	327	327	356	267	318	318	311	311	338	260
9000	75	309	257	341	197	372	132	296	250	325	190	355	125	281	242	309	183	336	118
	80	316	309	342	245	373	182	302	302	326	238	356	176	289	288	310	230	338	169
	85	331	331	343	293	373	232	318	318	328	286	357	225	305	305	311	278	338	218
	90	348	348	344	341	374	278	335	335	329	329	357	271	321	321	312	312	339	264
10000	75	315	272	346	206	377	134	301	265	330	199	359	128	285	256	313	192	340	121
	80	324	324	347	258	378	190	311	311	331	251	361	183	297	297	315	243	342	176
	85	342	342	348	311	378	245	329	329	333	304	361	238	314	314	315	296	343	231
	90	358	358	349	349	379	295	345	345	333	333	362	288	330	330	316	316	344	280
11000	75	319	286	350	215	370	163	305	279	334	208	363	130	289	270	317	201	344	123
	80	332	332	351	271	382	197	319	319	335	264	365	191	305	305	318	256	346	184
	85	350	350	352	329	383	258	337	337	336	321	365	247	322	322	319	314	346	240
	90	368	368	353	353	383	311	353	353	337	337	366	304	337	337	320	320	347	296
12000	75	323	300	354	224	368	182	309	293	338	217	367	133	292	284	320	206	347	126
	80	340	340	355	284	385	206	326	326	339	276	368	199	311	311	321	268	349	192
	85	358	358	356	347	386	266	344	344	340	339	368	258	328	328	322	322	349	251
	90	375	375	356	356	386	328	361	361	340	340	368	320	344	344	322	322	349	312
CFM	Ent DB °F	Ambient Temperature (°F)																	
		115																	
		Entering Wet Bulb Temperature (°F)																	
		61		67		73		61		67		73		61		67		73	
TGC	SHC	TGC	SHC	TGC	SHC	TGC	SHC	TGC	SHC	TGC	SHC	TGC	SHC	TGC	SHC	TGC	SHC		
8750	75	263	230	289	173	316	111												
	80	271	271	291	219	317	159												
	85	288	288	292	265	318	208												
	90	302	302	293	293	318	251												
9000	75	264	234	291	175	317	111												
	80	273	273	292	222	318	161												
	85	290	290	293	270	319	211												
	90	305	305	294	294	320	256												
10000	75	268	248	295	185	320	114												
	80	282	282	296	235	322	169												
	85	298	298	297	288	323	220												
	90	313	313	298	298	323	272												
11000	75	271	262	298	193	323	116												
	80	289	289	299	247	325	177												
	85	305	305	300	300	326	231												
	90	320	320	301	301	326	288												
12000	75	274	274	301	198	326	119												
	80	295	295	302	259	328	184												
	85	311	311	303	303	328	242												
	90	326	326	303	303	328	304												

**Notes:**

1. All capacities shown are gross and have not considered indoor fan heat. To obtain net cooling, subtract indoor fan heat.
2. TGC = Total gross capacity.
3. SHC = Sensible heat capacity.

### Performance Data (50 Hz Units)

**Table 38. 105 kw (29.2 ton) standard efficiency, gross cooling capacities — 1-row condenser coil (SI)—50 Hz**

L/s		Ent DB °C		Ambient Temperature (°C)															
				29.4				35.0				40.6							
				Entering Wet Bulb Temperature (°C)															
				16.1		19.4		22.8		16.1		19.4		22.8		16.1		19.4	
		TGC	SHC	TGC	SHC	TGC	SHC	TGC	SHC	TGC	SHC	TGC	SHC	TGC	SHC	TGC	SHC	TGC	SHC
4130	23.9	92.0	75.0	100.8	58.0	110.2	39.8	86.7	72.4	95.2	55.4	104.0	37.2	81.5	69.1	89.4	52.4	97.3	34.3
	26.7	93.5	89.4	101.4	71.8	111.0	54.2	88.5	86.4	95.8	68.9	104.6	51.6	82.9	82.9	90.0	65.6	98.2	48.6
	29.4	97.3	97.3	102.3	85.6	111.3	68.3	92.9	92.9	97.0	82.6	105.2	65.3	87.9	87.9	91.1	79.4	98.4	62.1
	32.2	102.5	102.5	103.7	99.3	111.9	81.5	97.9	97.9	98.4	96.4	105.8	78.5	92.6	92.6	92.6	92.6	99.3	75.6
4250	23.9	92.3	76.2	101.4	58.9	110.5	39.8	87.3	73.2	95.8	56.0	104.3	37.2	82.0	70.3	89.7	53.3	97.6	34.6
	26.7	94.1	90.8	102.0	72.7	111.3	54.8	89.1	87.9	96.4	69.7	105.2	52.2	83.8	83.8	90.2	66.8	98.4	49.2
	29.4	98.2	98.2	102.8	86.7	111.9	69.4	93.5	93.5	97.3	83.8	105.5	66.2	88.8	88.8	91.4	80.9	99.0	63.0
	32.2	103.4	103.4	104.3	101.1	112.5	82.6	98.7	98.7	99.0	98.2	106.4	79.7	93.5	93.5	93.5	93.5	99.9	76.8
4720	23.9	94.3	80.3	102.8	61.5	112.2	40.7	89.1	77.6	97.3	58.9	105.5	38.1	83.5	74.4	90.8	56.0	98.7	35.2
	26.7	96.1	96.1	103.7	76.5	113.1	57.1	91.4	91.4	97.9	73.5	106.7	54.2	86.4	86.4	91.7	70.3	99.9	51.6
	29.4	101.7	101.7	104.9	92.0	113.4	72.4	96.7	96.7	99.0	89.1	106.9	69.4	91.4	91.4	93.2	85.8	100.2	66.2
	32.2	106.9	106.9	106.9	106.9	114.3	87.6	102.0	102.0	101.7	101.7	108.1	84.7	96.4	96.4	96.4	96.4	101.4	81.5
5190	23.9	95.8	84.7	104.3	64.2	113.4	41.3	90.5	82.0	98.4	61.5	106.7	38.7	85.0	78.8	92.0	57.4	99.6	36.0
	26.7	98.7	98.7	105.2	80.3	114.3	59.2	93.8	93.8	99.3	77.1	107.8	56.5	88.5	88.5	93.2	73.8	100.8	53.9
	29.4	104.3	104.3	106.7	97.3	114.9	75.6	99.3	99.3	100.8	94.3	108.4	72.7	93.8	93.8	94.6	91.1	101.4	69.4
	32.2	109.9	109.9	109.9	109.9	116.0	92.3	104.6	104.6	104.6	104.6	109.3	89.4	98.7	98.7	98.7	98.7	102.5	86.1
5660	23.9	97.3	88.5	105.2	65.9	114.3	42.2	91.7	85.6	99.3	62.7	107.5	39.3	86.1	82.3	92.9	59.5	100.5	36.6
	26.7	101.1	101.1	106.4	83.8	115.4	61.5	96.1	96.1	100.5	80.9	108.4	58.3	90.5	90.5	94.1	77.4	101.4	55.1
	29.4	106.9	106.9	108.1	102.5	116.0	78.8	101.4	101.4	102.3	99.3	109.6	75.9	95.8	95.8	96.1	96.1	102.5	72.7
	32.2	112.5	112.5	112.5	112.5	117.2	97.0	106.9	106.9	106.9	106.9	110.8	94.1	100.8	100.8	100.8	100.8	103.7	90.5
L/s		Ent DB °C		Ambient Temperature (°C)															
				46.1															
				Entering Wet Bulb Temperature (°C)															
				16.1		19.4		22.8											
		TGC	SHC	TGC	SHC	TGC	SHC												
4130	23.9	75.9	65.9	82.9	49.5	90.2	31.4												
	26.7	77.9	77.9	83.5	62.4	91.1	45.7												
	29.4	82.6	82.6	84.7	76.2	91.7	58.9												
	32.2	87.0	87.0	87.0	87.0	92.3	72.1												
4250	23.9	76.2	67.1	83.2	50.4	90.5	31.6												
	26.7	78.5	78.5	84.1	63.3	91.4	46.3												
	29.4	83.2	83.2	85.3	77.4	92.0	59.8												
	32.2	87.9	87.9	87.9	87.9	92.9	73.2												
4720	23.9	77.6	71.2	84.4	53.0	91.4	32.2												
	26.7	80.9	80.9	85.3	67.1	92.6	48.6												
	29.4	85.8	85.8	86.7	82.6	93.2	63.0												
	32.2	90.2	90.2	90.2	90.2	94.1	77.9												
5190	23.9	78.8	75.3	85.3	53.9	92.3	33.1												
	26.7	82.9	82.9	86.4	70.6	93.5	50.7												
	29.4	87.9	87.9	88.2	87.6	94.1	65.9												
	32.2	92.6	92.6	92.6	92.6	95.2	82.6												
5660	23.9	80.0	79.4	86.1	56.0	92.9	33.7												
	26.7	84.7	84.7	87.3	73.8	94.1	51.6												
	29.4	89.7	89.7	89.7	89.7	94.9	69.1												
	32.2	94.3	94.3	94.3	94.3	96.4	87.0												

**Notes:**

1. All capacities shown are gross and have not considered indoor fan heat. To obtain net cooling, subtract indoor fan heat.
2. TGC = Total gross capacity.
3. SHC = Sensible heat capacity.



**Performance Data (50 Hz Units)**

**Table 39. 105 kw (29.2 ton) high efficiency - eStage, gross cooling capacities – 1-row condenser coil (SI)—50 Hz**

L/s	Ent DB °C	Ambient Temperature (°C)																	
		29.4						35.0						40.6					
		Entering Wet Bulb Temperature (°C)																	
		16.1		19.4		22.8		16.1		19.4		22.8		16.1		19.4		22.8	
TGC	SHC	TGC	SHC	TGC	SHC	TGC	SHC	TGC	SHC	TGC	SHC	TGC	SHC	TGC	SHC	TGC	SHC		
4130	23.9	90.2	74.2	99.4	57.0	108.5	38.4	86.3	72.2	95.0	55.0	103.6	36.5	81.9	69.9	90.1	52.9	98.2	34.5
	26.7	92.0	89.0	99.7	70.8	108.8	52.7	88.3	87.0	95.3	68.8	104.0	50.9	83.9	83.8	90.5	66.6	98.6	48.8
	29.4	96.2	96.2	100.1	84.6	109.0	67.1	92.6	92.5	95.7	82.5	104.2	65.1	88.6	88.6	90.9	80.2	98.9	63.1
	32.2	101.1	101.1	100.3	98.3	109.2	80.4	97.4	97.3	96.0	96.0	104.4	78.3	93.2	93.2	91.1	91.1	99.0	76.1
4250	23.9	90.7	75.3	99.9	57.7	108.9	38.6	86.7	73.2	95.4	55.7	104.0	36.7	82.3	71.0	90.5	53.6	98.6	34.7
	26.7	92.6	90.6	100.1	71.8	109.2	53.3	88.5	88.5	95.7	69.7	104.4	51.4	84.6	84.5	90.8	67.4	99.0	49.4
	29.4	97.0	97.0	100.5	85.9	109.4	68.0	93.3	93.3	96.1	83.8	104.5	66.1	89.4	89.4	91.2	81.5	99.2	64.0
	32.2	102.0	102.0	100.8	100.1	109.6	81.6	98.2	98.2	96.3	96.3	104.7	79.5	94.0	94.0	91.4	91.4	99.4	77.3
4720	23.9	92.3	79.7	101.4	60.4	110.4	39.3	88.3	77.6	96.8	58.4	105.3	37.4	83.6	75.2	91.7	56.3	99.8	35.4
	26.7	94.9	94.9	101.7	75.6	110.7	55.6	91.2	91.2	97.1	73.5	105.7	53.7	87.1	87.0	92.2	71.3	100.2	51.7
	29.4	100.1	100.1	102.0	91.2	110.8	71.7	96.3	96.3	97.5	89.1	105.8	69.8	92.0	92.0	92.4	86.8	100.5	67.8
	32.2	105.1	105.0	102.2	102.2	111.0	86.4	101.1	101.1	97.7	97.7	106.1	84.4	96.7	96.7	92.6	92.6	100.7	82.2
5190	23.9	93.6	83.8	102.7	63.1	108.5	47.7	89.4	81.7	98.0	61.1	106.4	38.2	84.7	79.3	92.9	58.9	100.8	36.2
	26.7	97.4	97.4	103.0	79.4	111.8	57.9	93.6	93.5	98.3	77.3	106.9	56.0	89.4	89.4	93.3	75.0	101.3	54.0
	29.4	102.7	102.6	103.2	96.5	112.1	75.5	98.7	98.7	98.4	94.2	107.0	72.5	94.3	94.3	93.4	91.9	101.5	70.2
	32.2	107.8	107.7	103.4	103.4	112.2	91.3	103.5	103.5	98.8	98.8	107.1	89.2	98.9	98.9	93.7	93.7	101.6	86.9
5660	23.9	94.7	87.9	103.7	65.7	108.0	53.3	90.5	85.8	98.9	63.6	107.4	38.9	85.6	83.3	93.8	60.4	101.7	36.9
	26.7	99.6	99.6	104.1	83.1	112.7	60.3	95.6	95.5	99.3	81.0	107.8	58.2	91.3	91.3	94.1	78.6	102.2	56.2
	29.4	104.9	104.9	104.3	101.6	113.1	77.9	100.8	100.8	99.5	99.4	107.9	75.7	96.2	96.2	94.3	94.3	102.3	73.5
	32.2	110.0	110.0	104.4	104.4	113.2	96.0	105.7	105.7	99.7	99.7	107.9	93.8	100.9	100.9	94.4	94.4	102.3	91.6
L/s	Ent DB °C	Ambient Temperature (°C)																	
		46.1																	
		Entering Wet Bulb Temperature (°C)																	
		16.1		19.4		22.8													
TGC	SHC	TGC	SHC	TGC	SHC														
4130	23.9	77.1	67.4	84.8	50.7	92.5	32.4												
	26.7	79.5	79.5	85.2	64.1	92.9	46.7												
	29.4	84.3	84.3	85.6	77.7	93.1	60.9												
	32.2	88.6	88.6	85.9	85.9	93.3	73.7												
4250	23.9	77.5	68.5	85.1	51.4	92.8	32.6												
	26.7	80.1	80.1	85.7	65.1	93.2	47.3												
	29.4	85.0	84.9	86.0	79.1	93.4	61.8												
	32.2	89.3	89.3	86.2	86.2	93.6	74.9												
4720	23.9	78.6	72.6	86.4	54.1	93.9	33.3												
	26.7	82.8	82.7	86.8	68.8	94.4	49.6												
	29.4	87.4	87.4	87.1	84.3	94.6	64.5												
	32.2	91.8	91.8	87.3	87.3	94.7	79.7												
5190	23.9	79.5	76.7	87.4	56.7	94.8	34.0												
	26.7	84.6	84.6	87.8	72.4	95.3	51.8												
	29.4	89.4	89.4	88.0	88.0	95.5	67.8												
	32.2	93.9	93.8	88.1	88.1	95.6	84.4												
5660	23.9	80.2	80.2	88.2	57.9	95.5	34.7												
	26.7	86.5	86.5	88.5	76.0	96.0	54.0												
	29.4	91.1	91.1	88.7	88.7	96.1	70.9												
	32.2	95.6	95.6	88.8	88.8	96.1	89.0												

**Notes:**  
1. All capacities shown are gross and have not considered indoor fan heat. To obtain net cooling, subtract indoor fan heat.  
2. TGC = Total gross capacity.  
3. SHC = Sensible heat capacity.



## Performance Data (50 Hz Units)

**Table 40. 33.3 ton standard efficiency, gross cooling capacities (MBh)—2-row condenser coil (I-P)—50 Hz**

CFM	Ent DB °F	Ambient Temperature (°F)																	
		85						95						105					
		Entering Wet Bulb Temperature (°F)																	
		61		67		73		61		67		73		61		67		73	
TGC	SHC	TGC	SHC	TGC	SHC	TGC	SHC	TGC	SHC	TGC	SHC	TGC	SHC	TGC	SHC	TGC	SHC		
10000	75	360	285	400	221	442	150	337	270	375	206	413	135	312	254	348	190	384	119
	80	366	341	402	275	445	207	343	325	377	259	417	192	319	309	350	242	387	176
	85	381	381	406	329	447	263	359	359	381	313	419	247	336	336	354	296	390	231
	90	403	403	412	384	449	316	381	381	387	368	421	300	357	357	360	351	392	283
11000	75	368	301	408	231	448	153	344	285	381	216	419	138	319	269	354	200	389	122
	80	375	362	410	289	452	215	351	346	384	272	423	200	326	326	356	256	393	184
	85	394	394	415	348	454	276	372	372	389	332	425	259	348	348	361	315	395	242
	90	417	417	421	408	457	333	394	394	394	394	428	316	369	369	370	367	398	299
12000	75	374	315	413	241	454	156	350	300	387	225	424	141	324	283	358	209	393	125
	80	382	382	416	302	458	223	360	358	390	286	428	208	336	336	362	268	397	192
	85	406	406	422	366	460	287	382	382	395	350	430	270	358	358	367	332	400	253
	90	429	429	429	429	463	350	405	405	406	405	434	333	380	380	380	380	404	316
13000	75	380	330	419	250	458	159	356	313	391	235	428	143	329	296	362	219	397	127
	80	391	391	422	315	463	231	369	369	395	298	433	216	344	344	366	281	401	199
	85	416	416	428	384	465	299	392	392	401	368	435	282	367	367	373	350	404	264
	90	440	440	440	440	469	366	415	415	415	415	439	349	389	389	389	389	408	332
14600	75	389	352	425	262	465	163	363	336	397	245	434	147	337	318	367	227	402	131
	80	405	405	430	335	467	243	381	381	402	318	439	228	356	356	373	300	405	208
	85	431	431	437	413	472	316	406	406	409	395	442	299	379	379	379	379	410	282
	90	455	455	455	455	477	392	429	429	429	429	446	375	401	401	401	401	415	357

CFM	Ent DB °F	Ambient Temperature (°F)					
		115					
		Entering Wet Bulb Temperature (°F)					
		61		67		73	
TGC	SHC	TGC	SHC	TGC	SHC		
10000	75	287	237	319	174	352	103
	80	292	292	322	225	356	159
	85	312	312	326	279	358	213
	90	332	332	332	332	361	265
11000	75	292	251	324	183	357	106
	80	302	302	327	238	361	167
	85	323	323	332	297	363	224
	90	343	343	343	343	366	281
12000	75	298	265	328	193	361	108
	80	311	311	332	250	365	175
	85	332	332	338	314	367	235
	90	352	352	352	352	371	297
13000	75	302	278	332	197	364	111
	80	318	318	336	263	368	183
	85	340	340	343	332	371	246
	90	361	361	360	360	375	313
14600	75	309	300	337	209	368	115
	80	329	329	342	282	372	190
	85	351	351	350	350	376	263
	90	372	372	372	372	381	338

**Notes:**

1. All capacities shown are gross and have not considered indoor fan heat. To obtain net cooling, subtract indoor fan heat.
2. TGC = Total gross capacity.
3. SHC = Sensible heat capacity.



**Performance Data (50 Hz Units)**

**Table 41. 33.3 ton high efficiency - eStage, gross cooling capacities (MBh)—2-row condenser coil (I-P)—50 Hz**

CFM	Ent DB °F	Ambient Temperature (°F)																	
		85						95						105					
		Entering Wet Bulb Temperature (°F)																	
		61		67		73		61		67		73		61		67		73	
TGC	SHC	TGC	SHC	TGC	SHC	TGC	SHC	TGC	SHC	TGC	SHC	TGC	SHC	TGC	SHC	TGC	SHC		
10000	75	365	294	378	272	453	157	348	285	389	218	403	196	329	276	369	210	382	187
	80	372	352	395	305	454	213	355	343	389	274	411	240	337	334	368	265	410	196
	85	389	389	411	338	454	268	374	374	392	329	433	260	358	358	371	320	411	251
	90	411	411	412	392	454	323	396	396	393	383	433	315	379	379	373	373	412	306
11000	75	372	310	416	238	459	161	354	301	395	228	400	221	335	292	375	219	388	194
	80	381	374	417	298	459	221	364	364	396	289	410	264	348	348	376	280	415	204
	85	403	403	418	357	460	281	387	387	399	349	440	273	370	370	377	339	416	265
	90	425	425	419	417	461	341	409	409	400	400	440	333	392	392	379	379	417	324
12000	75	378	326	422	281	464	165	360	317	386	264	443	158	340	307	380	228	392	201
	80	391	391	423	329	465	230	375	375	403	303	444	222	358	358	381	294	400	253
	85	415	415	424	377	466	294	398	398	404	368	445	286	381	381	382	358	421	278
	90	438	438	425	425	466	359	421	421	405	405	445	351	403	403	383	383	422	341
13000	75	377	377	388	357	469	169	365	333	394	277	447	161	344	323	383	237	399	208
	80	401	401	399	384	469	238	385	385	406	318	448	230	367	367	385	308	404	265
	85	425	425	429	396	470	307	409	409	409	387	449	299	390	390	387	378	425	290
	90	449	449	430	430	471	377	432	432	410	410	450	368	412	412	388	388	426	359
14600	75	391	391	433	407	474	175	371	357	382	327	453	164	350	347	389	252	394	242
	80	415	415	434	417	475	252	398	398	393	388	453	242	379	379	391	329	404	297
	85	440	440	435	426	476	328	422	422	415	415	454	319	403	403	392	392	430	310
	90	463	463	436	436	477	405	446	446	416	416	455	396	425	425	393	393	431	387
CFM	Ent DB °F	Ambient Temperature (°F)																	
		115																	
		Entering Wet Bulb Temperature (°F)																	
		61		67		73		61		67		73		61		67		73	
TGC	SHC	TGC	SHC	TGC	SHC	TGC	SHC	TGC	SHC	TGC	SHC	TGC	SHC	TGC	SHC	TGC	SHC		
10000	75	309	266	346	200	384	132												
	80	319	319	348	255	385	187												
	85	340	340	349	310	387	242												
	90	361	361	350	350	388	296												
11000	75	314	282	352	209	389	134												
	80	330	330	353	270	390	195												
	85	351	351	354	329	392	255												
	90	372	372	356	356	393	314												
12000	75	319	297	356	219	368	191												
	80	339	339	358	284	395	203												
	85	361	361	359	348	396	268												
	90	383	383	360	360	397	332												
13000	75	322	312	360	228	378	183												
	80	347	347	361	297	398	210												
	85	370	370	363	363	399	280												
	90	391	391	364	364	400	349												
14600	75	327	327	365	242	402	145												
	80	359	359	366	319	403	222												
	85	382	382	368	368	404	300												
	90	403	403	369	369	405	377												

**Notes:**

1. All capacities shown are gross and have not considered indoor fan heat. To obtain net cooling, subtract indoor fan heat.
2. TGC = Total gross capacity.
3. SHC = Sensible heat capacity.

Performance Data (50 Hz Units)

Table 42. 120 kW (33.3 ton) standard efficiency, gross cooling capacities—2-row condenser coil (SI)—50 Hz

L/s	Ent DB °C	Ambient Temperature (°C)																	
		29.4						35.0						40.6					
		Entering Wet Bulb Temperature (°C)																	
		16.1		19.4		22.8		16.1		19.4		22.8		16.1		19.4		22.8	
TGC	SHC	TGC	SHC	TGC	SHC	TGC	SHC	TGC	SHC	TGC	SHC	TGC	SHC	TGC	SHC	TGC	SHC		
4720	23.9	105.5	83.5	117.2	64.8	129.5	43.9	98.7	79.1	109.9	60.4	121.0	39.6	91.4	74.4	102.0	55.7	112.5	34.9
	26.7	107.2	99.9	117.8	80.6	130.4	60.7	100.5	95.2	110.5	75.9	122.2	56.3	93.5	90.5	102.5	70.9	113.4	51.6
	29.4	111.6	111.6	119.0	96.4	131.0	77.1	105.2	105.2	111.6	91.7	122.8	72.4	98.4	98.4	103.7	86.7	114.3	67.7
	32.2	118.1	118.1	120.7	112.5	131.6	92.6	111.6	111.6	113.4	107.8	123.4	87.9	104.6	104.6	105.5	102.8	114.9	82.9
5190	23.9	107.8	88.2	119.5	67.7	131.3	44.8	100.8	83.5	111.6	63.3	122.8	40.4	93.5	78.8	103.7	58.6	114.0	35.7
	26.7	109.9	106.1	120.1	84.7	132.4	63.0	102.8	101.4	112.5	79.7	123.9	58.6	95.5	95.5	104.3	75.0	115.1	53.9
	29.4	115.4	115.4	121.6	102.0	133.0	80.9	109.0	109.0	114.0	97.3	124.5	75.9	102.0	102.0	105.8	92.3	115.7	70.9
	32.2	122.2	122.2	123.4	119.5	133.9	97.6	115.4	115.4	115.4	115.4	125.4	92.6	108.1	108.1	108.4	107.5	116.6	87.6
5660	23.9	109.6	92.3	121.0	70.6	133.0	45.7	102.5	87.9	113.4	65.9	124.2	41.3	94.9	82.9	104.9	61.2	115.1	36.6
	26.7	111.9	111.9	121.9	88.5	134.2	65.3	105.5	104.9	114.3	83.8	125.4	60.9	98.4	98.4	106.1	78.5	116.3	56.3
	29.4	119.0	119.0	123.6	107.2	134.8	84.1	111.9	111.9	115.7	102.5	126.0	79.1	104.9	104.9	107.5	97.3	117.2	74.1
	32.2	125.7	125.7	125.7	125.7	135.7	102.5	118.7	118.7	119.0	118.7	127.2	97.6	111.3	111.3	111.3	111.3	118.4	92.6
6140	23.9	111.3	96.7	122.8	73.2	134.2	46.6	104.3	91.7	114.6	68.9	125.4	41.9	96.4	86.7	106.1	64.2	116.3	37.2
	26.7	114.6	114.6	123.6	92.3	135.7	67.7	108.1	108.1	115.7	87.3	126.9	63.3	100.8	100.8	107.2	82.3	117.5	58.3
	29.4	121.9	121.9	125.4	112.5	136.2	87.6	114.9	114.9	117.5	107.8	127.5	82.6	107.5	107.5	109.3	102.5	118.4	77.4
	32.2	128.9	128.9	128.9	128.9	137.4	107.2	121.6	121.6	121.6	121.6	128.6	102.3	114.0	114.0	114.0	114.0	119.5	97.3
6890	23.9	114.0	103.1	124.5	76.8	136.2	47.8	106.4	98.4	116.3	71.8	127.2	43.1	98.7	93.2	107.5	66.5	117.8	38.4
	26.7	118.7	118.7	126.0	98.2	136.8	71.2	111.6	111.6	117.8	93.2	128.6	66.8	104.3	104.3	109.3	87.9	118.7	60.9
	29.4	126.3	126.3	128.0	121.0	138.3	92.6	119.0	119.0	119.8	115.7	129.5	87.6	111.0	111.0	111.0	111.0	120.1	82.6
	32.2	133.3	133.3	133.3	133.3	139.8	114.9	125.7	125.7	125.7	125.7	130.7	109.9	117.5	117.5	117.5	117.5	121.6	104.6
L/s	Ent DB °C	Ambient Temperature (°C)																	
		46.1																	
		Entering Wet Bulb Temperature (°C)																	
		16.1		19.4		22.8		16.1		19.4		22.8		16.1		19.4		22.8	
TGC	SHC	TGC	SHC	TGC	SHC	TGC	SHC	TGC	SHC	TGC	SHC	TGC	SHC	TGC	SHC	TGC	SHC		
4720	23.9	84.1	69.4	93.5	51.0	103.1	30.2												
	26.7	85.6	85.6	94.3	65.9	104.3	46.6												
	29.4	91.4	91.4	95.5	81.7	104.9	62.4												
	32.2	97.3	97.3	97.3	97.3	105.8	77.6												
5190	23.9	85.6	73.5	94.9	53.6	104.6	31.1												
	26.7	88.5	88.5	95.8	69.7	105.8	48.9												
	29.4	94.6	94.6	97.3	87.0	106.4	65.6												
	32.2	100.5	100.5	100.5	100.5	107.2	82.3												
5660	23.9	87.3	77.6	96.1	56.5	105.8	31.6												
	26.7	91.1	91.1	97.3	73.2	106.9	51.3												
	29.4	97.3	97.3	99.0	92.0	107.5	68.9												
	32.2	103.1	103.1	103.1	103.1	108.7	87.0												
6140	23.9	88.5	81.5	97.3	57.7	106.7	32.5												
	26.7	93.2	93.2	98.4	77.1	107.8	53.6												
	29.4	99.6	99.6	100.5	97.3	108.7	72.1												
	32.2	105.8	105.8	105.5	105.5	109.9	91.7												
6890	23.9	90.5	87.9	98.7	61.2	107.8	33.7												
	26.7	96.4	96.4	100.2	82.6	109.0	55.7												
	29.4	102.8	102.8	102.5	102.5	110.2	77.1												
	32.2	109.0	109.0	109.0	109.0	111.6	99.0												

**Notes:**  
 1. All capacities shown are gross and have not considered indoor fan heat. To obtain net cooling, subtract indoor fan heat.  
 2. TGC = Total gross capacity.  
 3. SHC = Sensible heat capacity.



**Performance Data (50 Hz Units)**

**Table 43. 120 kW (33.3 ton) high efficiency - eStage, gross cooling capacities—2-row condenser coil (SI)—50 Hz**

L/s	Ent DB °C	Ambient Temperature (°C)																	
		29.4						35.0						40.6					
		Entering Wet Bulb Temperature (°C)																	
		16.1		19.4		22.8		16.1		19.4		22.8		16.1		19.4		22.8	
TGC	SHC	TGC	SHC	TGC	SHC	TGC	SHC	TGC	SHC	TGC	SHC	TGC	SHC	TGC	SHC	TGC	SHC		
4720	23.9	107.0	86.2	110.8	79.7	132.9	46.1	101.9	83.6	113.9	64.0	118.2	57.5	96.5	80.9	108.1	61.4	112.0	54.7
	26.7	108.9	103.1	115.8	89.5	132.9	62.3	104.0	100.5	114.1	80.3	120.4	70.2	98.8	97.8	108.0	77.7	120.1	57.5
	29.4	113.9	113.9	120.4	98.9	132.9	78.5	109.6	109.6	114.9	96.4	127.0	76.2	104.8	104.8	108.8	93.7	120.4	73.6
	32.2	120.5	120.5	120.7	114.9	133.0	94.7	116.0	116.0	115.2	112.3	127.0	92.3	111.1	111.1	109.2	109.2	120.7	89.7
5190	23.9	109.1	90.9	121.8	69.7	134.4	47.3	103.9	88.3	115.8	66.8	117.1	64.7	98.2	85.5	109.8	64.2	113.7	56.8
	26.7	111.7	109.6	122.1	87.2	134.6	64.8	106.8	106.8	116.0	84.7	120.2	77.3	101.9	101.9	110.2	81.9	121.6	59.8
	29.4	118.0	118.0	122.5	104.7	134.9	82.4	113.4	113.4	116.8	102.2	128.8	80.1	108.4	108.4	110.6	99.4	122.1	77.5
	32.2	124.7	124.7	122.8	122.3	135.1	100.0	120.0	120.0	117.1	117.1	129.1	97.6	114.8	114.8	110.9	110.9	122.3	94.9
5660	23.9	110.8	95.6	123.6	82.3	136.0	48.4	105.5	92.9	113.1	77.5	129.7	46.3	99.7	90.1	111.3	66.9	114.9	58.9
	26.7	114.5	114.5	123.9	96.3	136.2	67.3	109.9	109.9	118.0	88.8	130.0	65.1	104.9	104.9	111.7	86.1	117.1	74.3
	29.4	121.5	121.5	124.2	110.4	136.4	86.3	116.8	116.8	118.4	107.9	130.3	83.9	111.6	111.6	112.1	105.1	123.4	81.4
	32.2	128.4	128.4	124.5	124.5	136.7	105.2	123.5	123.5	118.7	118.7	130.5	102.8	118.0	118.0	112.4	112.4	123.7	100.1
6140	23.9	110.5	110.5	113.8	104.7	137.3	49.6	106.9	97.5	115.5	81.1	130.9	47.3	100.9	94.6	112.1	69.6	116.9	61.0
	26.7	117.5	117.5	116.9	112.5	137.6	69.8	112.7	112.7	118.9	93.3	131.2	67.5	107.5	107.5	112.9	90.1	118.3	77.6
	29.4	124.6	124.6	125.7	116.1	137.8	90.1	119.7	119.7	119.8	113.5	131.5	87.7	114.3	114.3	113.3	110.7	124.5	85.0
	32.2	131.5	131.5	126.0	126.0	138.0	110.4	126.5	126.5	120.1	120.1	131.8	107.9	120.8	120.8	113.6	113.6	124.8	105.2
6890	23.9	114.6	114.6	127.0	119.2	139.0	51.3	108.7	104.6	112.0	95.9	132.7	48.2	102.6	101.7	114.1	73.7	115.6	70.8
	26.7	121.6	121.6	127.3	122.1	139.2	73.7	116.6	116.6	115.1	113.7	132.9	70.8	111.1	111.1	114.5	96.6	118.3	87.1
	29.4	128.9	128.9	127.6	125.0	139.5	96.1	123.8	123.8	121.5	121.5	133.1	93.4	118.0	118.0	114.9	114.9	126.0	90.8
	32.2	135.8	135.8	127.8	127.8	139.7	118.6	130.6	130.6	121.8	121.8	133.3	116.1	124.6	124.6	115.2	115.2	126.2	113.4
L/s	Ent DB °C	Ambient Temperature (°C)																	
		46.1																	
		Entering Wet Bulb Temperature (°C)																	
		16.1		19.4		22.8		16.1		19.4		22.8		16.1		19.4		22.8	
TGC	SHC	TGC	SHC	TGC	SHC	TGC	SHC	TGC	SHC	TGC	SHC	TGC	SHC	TGC	SHC	TGC	SHC		
4720	23.9	90.5	78.0	101.5	58.6	112.6	38.6												
	26.7	93.5	93.5	101.9	74.8	113.0	54.8												
	29.4	99.6	99.6	102.3	90.7	113.3	70.9												
	32.2	105.7	105.7	102.7	102.7	113.6	86.8												
5190	23.9	92.1	82.6	103.1	61.4	114.1	39.3												
	26.7	96.6	96.6	103.5	79.0	114.4	57.1												
	29.4	103.0	103.0	103.9	96.4	114.8	74.8												
	32.2	109.1	109.1	104.2	104.2	115.1	92.0												
5660	23.9	93.4	87.1	104.4	64.1	107.8	56.1												
	26.7	99.4	99.4	104.8	83.1	115.7	59.4												
	29.4	105.9	105.9	105.2	102.1	116.0	78.7												
	32.2	112.1	112.1	105.5	105.5	116.3	97.2												
6140	23.9	94.5	91.6	105.5	66.8	110.7	53.8												
	26.7	101.8	101.8	105.9	87.1	116.5	61.7												
	29.4	108.4	108.4	106.3	106.3	117.0	82.2												
	32.2	114.7	114.7	106.6	106.6	117.3	102.3												
6890	23.9	96.0	96.0	106.9	71.0	117.8	42.5												
	26.7	105.1	105.1	107.4	93.5	118.1	65.2												
	29.4	111.8	111.8	107.7	107.7	118.3	87.9												
	32.2	118.1	118.1	108.0	108.0	118.6	110.5												

**Notes:**  
 1. All capacities shown are gross and have not considered indoor fan heat. To obtain net cooling, subtract indoor fan heat.  
 2. TGC = Total gross capacity.  
 3. SHC = Sensible heat capacity.

## Performance Data (50 Hz Units)

**Table 44. 41.7 ton standard efficiency, gross cooling capacities (MBh)—2-row condenser coil (I-P)—50 Hz**

CFM	Ent DB °F	Ambient Temperature (°F)																	
		85						95						105					
		Entering Wet Bulb Temperature (°F)																	
		61		67		73		61		67		73		61		67		73	
TGC	SHC	TGC	SHC	TGC	SHC	TGC	SHC	TGC	SHC	TGC	SHC	TGC	SHC	TGC	SHC	TGC	SHC		
12500	75	449	365	497	282	545	193	423	349	467	267	512	178	394	332	436	251	477	162
	80	457	435	499	350	549	264	431	419	470	334	517	249	402	402	439	317	482	233
	85	477	477	505	418	552	335	453	453	475	402	520	319	427	427	444	384	484	301
	90	504	504	512	487	555	401	479	479	483	471	523	384	452	452	453	447	488	367
13500	75	457	380	503	292	552	196	429	364	473	277	518	181	401	347	441	260	482	165
	80	466	456	506	364	556	273	438	438	476	347	522	257	412	412	444	330	487	241
	85	490	490	512	437	558	346	465	465	482	420	525	330	438	438	451	403	489	312
	90	518	518	518	518	562	418	491	491	492	488	529	401	463	463	463	463	494	383
14500	75	463	395	509	302	557	199	435	379	478	286	522	183	406	361	445	270	486	167
	80	473	473	513	377	562	281	448	448	482	360	527	265	421	421	450	343	491	249
	85	502	502	519	456	564	358	475	475	489	439	530	341	447	447	456	421	494	324
	90	530	530	531	529	569	435	503	503	502	502	535	418	473	473	473	473	500	400
15500	75	469	409	514	311	561	201	441	394	482	295	526	186	411	376	449	279	490	170
	80	483	483	518	390	566	289	457	457	487	373	532	273	429	429	454	355	495	257
	85	512	512	526	474	569	370	485	485	495	457	535	353	456	456	462	439	499	335
	90	541	541	541	541	575	451	513	513	512	512	540	434	482	482	482	482	504	416
16500	75	474	424	518	321	565	204	446	408	485	300	530	188	415	390	452	282	493	172
	80	492	492	523	403	571	296	465	465	492	386	536	281	437	437	458	368	499	265
	85	521	521	531	492	574	381	494	494	500	475	539	364	464	464	467	456	503	346
	90	551	551	550	550	580	468	522	522	521	521	545	450	491	491	490	490	509	432
CFM	Ent DB °F	Ambient Temperature (°F)																	
		115																	
		Entering Wet Bulb Temperature (°F)																	
		61		67		73		61		67		73		61		67		73	
TGC	SHC	TGC	SHC	TGC	SHC	TGC	SHC	TGC	SHC	TGC	SHC	TGC	SHC	TGC	SHC	TGC	SHC		
12500	75	364	314	402	234	440	146												
	80	375	375	406	299	445	216												
	85	399	399	411	366	447	283												
	90	423	423	422	422	452	348												
13500	75	370	329	407	244	444	148												
	80	384	384	411	311	450	224												
	85	409	409	417	384	452	294												
	90	433	433	433	433	457	365												
14500	75	375	343	409	248	448	151												
	80	392	392	415	324	453	232												
	85	417	417	422	402	457	305												
	90	442	442	442	442	462	381												
15500	75	379	357	413	256	451	153												
	80	400	400	419	336	457	240												
	85	425	425	425	425	461	316												
	90	450	450	450	450	466	397												
16500	75	384	370	417	263	453	156												
	80	406	406	423	349	458	243												
	85	432	432	433	430	464	327												
	90	458	458	457	457	470	413												

**Notes:**

1. All capacities shown are gross and have not considered indoor fan heat. To obtain net cooling, subtract indoor fan heat.
2. TGC = Total gross capacity.
3. SHC = Sensible heat capacity.



**Performance Data (50 Hz Units)**

**Table 45. 41.7 ton high efficiency - eStage, gross cooling capacities (MBh)—2-row condenser coil (I-P)—50 Hz**

CFM	Ent DB °F	Ambient Temperature (°F)																	
		85						95						105					
		Entering Wet Bulb Temperature (°F)																	
		61		67		73		61		67		73		61		67		73	
TGC	SHC	TGC	SHC	TGC	SHC	TGC	SHC	TGC	SHC	TGC	SHC	TGC	SHC	TGC	SHC	TGC	SHC		
12500	75	435	357	484	276	507	232	416	347	462	267	507	178	394	337	438	257	481	169
	80	444	428	486	345	532	258	425	418	464	335	510	249	405	405	440	324	484	240
	85	466	466	488	412	534	329	449	449	466	403	510	320	430	430	442	392	485	310
	90	492	492	489	480	535	396	474	474	467	467	512	387	455	455	444	444	486	377
13500	75	442	373	487	285	512	238	421	363	468	276	489	229	400	352	443	266	485	171
	80	453	450	492	359	513	315	434	434	470	349	515	258	415	415	446	338	488	248
	85	479	479	494	432	540	342	461	461	471	422	516	332	441	441	447	412	489	322
	90	505	505	495	495	541	415	486	486	473	473	517	405	466	466	449	449	491	395
14500	75	447	388	492	295	509	261	427	378	472	286	493	235	404	367	448	276	489	174
	80	462	462	497	373	518	326	444	444	475	363	517	266	425	425	450	352	492	256
	85	490	490	499	451	544	356	471	471	476	441	520	345	451	451	452	430	493	334
	90	516	516	500	500	545	432	497	497	478	478	521	423	475	475	453	453	494	412
15500	75	452	403	497	304	484	337	431	393	477	295	497	241	408	382	452	285	493	177
	80	472	472	502	387	522	338	453	453	479	377	521	274	433	433	454	366	496	264
	85	500	500	503	470	548	370	480	480	480	460	524	357	459	459	456	449	497	347
	90	526	526	505	505	549	449	506	506	482	482	525	440	484	484	457	457	498	430
16500	75	457	418	500	314	488	348	435	408	480	305	500	247	412	397	455	295	496	179
	80	480	480	506	400	521	364	461	461	483	390	525	282	441	441	457	379	499	272
	85	509	509	507	489	552	379	489	489	484	479	527	369	467	467	459	459	500	358
	90	535	535	509	509	552	467	514	514	485	485	528	457	491	491	460	460	500	447
CFM	Ent DB °F	Ambient Temperature (°F)																	
		115																	
		Entering Wet Bulb Temperature (°F)																	
		61		67		73		61		67		73		61		67		73	
TGC	SHC	TGC	SHC	TGC	SHC	TGC	SHC	TGC	SHC	TGC	SHC	TGC	SHC	TGC	SHC	TGC	SHC		
12500	75	371	325	413	246	452	159												
	80	385	385	415	313	456	230												
	85	410	410	417	381	457	299												
	90	433	433	418	418	458	366												
13500	75	376	340	417	256	456	161												
	80	395	395	420	327	460	238												
	85	420	420	422	400	461	311												
	90	443	443	423	423	462	384												
14500	75	380	356	421	265	460	164												
	80	404	404	424	341	463	246												
	85	428	428	425	419	465	323												
	90	452	452	427	427	466	401												
15500	75	384	370	425	275	463	166												
	80	411	411	427	354	467	254												
	85	436	436	429	429	468	335												
	90	460	460	430	430	469	418												
16500	75	387	385	427	284	465	169												
	80	418	418	430	367	469	262												
	85	443	443	432	432	470	347												
	90	467	467	433	433	471	436												

**Notes:**

1. All capacities shown are gross and have not considered indoor fan heat. To obtain net cooling, subtract indoor fan heat.
2. TGC = Total gross capacity.
3. SHC = Sensible heat capacity.



Performance Data (50 Hz Units)

Table 46. 148 kW (41.7 ton) standard efficiency, gross cooling capacities—2-row condenser coil (SI)—50 Hz

L/s		Ent DB °C		Ambient Temperature (°C)																	
				29.4						35.0						40.6					
				Entering Wet Bulb Temperature (°C)																	
				16.1		19.4		22.8		16.1		19.4		22.8		16.1		19.4		22.8	
TGC	SHC	TGC	SHC	TGC	SHC	TGC	SHC	TGC	SHC	TGC	SHC	TGC	SHC	TGC	SHC	TGC	SHC				
5900	23.9	131.6	106.9	145.6	82.6	159.7	56.5	123.9	102.3	136.8	78.2	150.0	52.2	115.4	97.3	127.7	73.5	139.8	47.5		
	26.7	133.9	127.5	146.2	102.5	160.9	77.4	126.3	122.8	137.7	97.9	151.5	73.0	117.8	117.8	128.6	92.9	141.2	68.3		
	29.4	139.8	139.8	148.0	122.5	161.7	98.2	132.7	132.7	139.2	117.8	152.4	93.5	125.1	125.1	130.1	112.5	141.8	88.2		
	32.2	147.7	147.7	150.0	142.7	162.6	117.5	140.3	140.3	141.5	138.0	153.2	112.5	132.4	132.4	132.7	131.0	143.0	107.5		
6370	23.9	133.9	111.3	147.4	85.6	161.7	57.4	125.7	106.7	138.6	81.2	151.8	53.0	117.5	101.7	129.2	76.2	141.2	48.3		
	26.7	136.5	133.6	148.3	106.7	162.9	80.0	128.3	128.3	139.5	101.7	152.9	75.3	120.7	120.7	130.1	96.7	142.7	70.6		
	29.4	143.6	143.6	150.0	128.0	163.5	101.4	136.2	136.2	141.2	123.1	153.8	96.7	128.3	128.3	132.1	118.1	143.3	91.4		
	32.2	151.8	151.8	151.8	151.8	164.7	122.5	143.9	143.9	144.2	143.0	155.0	117.5	135.7	135.7	135.7	135.7	144.7	112.2		
6840	23.9	135.7	115.7	149.1	88.5	163.2	58.3	127.5	111.0	140.1	83.8	152.9	53.6	119.0	105.8	130.4	79.1	142.4	48.9		
	26.7	138.6	138.6	150.3	110.5	164.7	82.3	131.3	131.3	141.2	105.5	154.4	77.6	123.4	123.4	131.8	100.5	143.9	73.0		
	29.4	147.1	147.1	152.1	133.6	165.3	104.9	139.2	139.2	143.3	128.6	155.3	99.9	131.0	131.0	133.6	123.4	144.7	94.9		
	32.2	155.3	155.3	155.6	155.0	166.7	127.5	147.4	147.4	147.1	147.1	156.8	122.5	138.6	138.6	138.6	138.6	146.5	117.2		
7320	23.9	137.4	119.8	150.6	91.1	164.4	58.9	129.2	115.4	141.2	86.4	154.1	54.5	120.4	110.2	131.6	81.7	143.6	49.8		
	26.7	141.5	141.5	151.8	114.3	165.8	84.7	133.9	133.9	142.7	109.3	155.9	80.0	125.7	125.7	133.0	104.0	145.0	75.3		
	29.4	150.0	150.0	154.1	138.9	166.7	108.4	142.1	142.1	145.0	133.9	156.8	103.4	133.6	133.6	135.4	128.6	146.2	98.2		
	32.2	158.5	158.5	158.5	158.5	168.5	132.1	150.3	150.3	150.0	150.0	158.2	127.2	141.2	141.2	141.2	141.2	147.7	121.9		
7790	23.9	138.9	124.2	151.8	94.1	165.5	59.8	130.7	119.5	142.1	87.9	155.3	55.1	121.6	114.3	132.4	82.6	144.4	50.4		
	26.7	144.2	144.2	153.2	118.1	167.3	86.7	136.2	136.2	144.2	113.1	157.0	82.3	128.0	128.0	134.2	107.8	146.2	77.6		
	29.4	152.7	152.7	155.6	144.2	168.2	111.6	144.7	144.7	146.5	139.2	157.9	106.7	136.0	136.0	136.8	133.6	147.4	101.4		
	32.2	161.4	161.4	161.1	161.1	169.9	137.1	152.9	152.9	152.7	152.7	159.7	131.8	143.9	143.9	143.6	143.6	149.1	126.6		
L/s		Ent DB °C		Ambient Temperature (°C)																	
				46.1																	
				Entering Wet Bulb Temperature (°C)																	
				16.1		19.4		22.8		16.1		19.4		22.8		16.1		19.4		22.8	
5900	23.9	106.7	92.0	117.8	68.6	128.9	42.8														
	26.7	109.9	109.9	119.0	87.6	130.4	63.3														
	29.4	116.9	116.9	120.4	107.2	131.0	82.9														
	32.2	123.9	123.9	123.6	123.6	132.4	102.0														
6370	23.9	108.4	96.4	119.2	71.5	130.1	43.4														
	26.7	112.5	112.5	120.4	91.1	131.8	65.6														
	29.4	119.8	119.8	122.2	112.5	132.4	86.1														
	32.2	126.9	126.9	126.9	126.9	133.9	106.9														
6840	23.9	109.9	100.5	119.8	72.7	131.3	44.2														
	26.7	114.9	114.9	121.6	94.9	132.7	68.0														
	29.4	122.2	122.2	123.6	117.8	133.9	89.4														
	32.2	129.5	129.5	129.5	129.5	135.4	111.6														
7320	23.9	111.0	104.6	121.0	75.0	132.1	44.8														
	26.7	117.2	117.2	122.8	98.4	133.9	70.3														
	29.4	124.5	124.5	124.5	124.5	135.1	92.6														
	32.2	131.8	131.8	131.8	131.8	136.5	116.3														
7790	23.9	112.5	108.4	122.2	77.1	132.7	45.7														
	26.7	119.0	119.0	123.9	102.3	134.2	71.2														
	29.4	126.6	126.6	126.9	126.0	136.0	95.8														
	32.2	134.2	134.2	133.9	133.9	137.7	121.0														

- Notes:**
- 1. All capacities shown are gross and have not considered indoor fan heat. To obtain net cooling, subtract indoor fan heat.
  - 2. TGC = Total gross capacity.
  - 3. SHC = Sensible heat capacity.



### Performance Data (50 Hz Units)

**Table 47. 148 kW (41.7 ton) high efficiency - eStage, gross cooling capacities—2-row condenser coil (SI)—50 Hz**

L/s		Ent DB °C		Ambient Temperature (°C)															
				29.4				35.0				40.6							
				Entering Wet Bulb Temperature (°C)															
				16.1		19.4		22.8		16.1		19.4		22.8		16.1		19.4	
TGC SHC		TGC SHC		TGC SHC		TGC SHC		TGC SHC		TGC SHC		TGC SHC		TGC SHC		TGC SHC			
5900	23.9	127.6	104.7	141.9	80.9	148.5	68.0	121.8	101.7	135.4	78.1	148.7	52.3	115.5	98.6	128.5	75.3	140.9	49.5
	26.7	130.2	125.3	142.3	101.0	155.9	75.7	124.6	122.5	135.9	98.2	149.3	73.1	118.7	118.7	129.0	95.1	141.7	70.3
	29.4	136.6	136.6	142.9	120.9	156.6	96.3	131.6	131.6	136.5	118.0	149.6	93.7	126.1	126.1	129.6	114.9	142.1	90.7
	32.2	144.2	144.2	143.3	140.7	156.9	116.2	139.0	139.0	137.0	137.0	150.0	113.4	133.2	133.2	130.1	130.1	142.5	110.5
6370	23.9	129.5	109.3	142.8	83.6	150.2	69.8	123.5	106.3	137.0	81.0	143.2	67.1	117.1	103.2	130.0	78.1	142.3	50.2
	26.7	132.8	131.8	144.1	105.2	150.4	92.2	127.3	127.3	137.6	102.3	150.8	75.5	121.8	121.8	130.6	99.2	143.1	72.7
	29.4	140.3	140.3	144.7	126.6	158.2	100.4	135.0	135.0	138.2	123.7	151.1	97.4	129.3	129.3	131.1	120.7	143.4	94.4
	32.2	147.9	147.9	145.1	145.1	158.5	121.5	142.5	142.5	138.6	138.6	151.5	118.7	136.5	136.5	131.6	131.6	143.8	115.7
6840	23.9	131.1	113.8	144.2	86.4	149.2	76.6	125.0	110.8	138.5	83.8	144.5	68.9	118.5	107.6	131.2	80.9	143.4	51.0
	26.7	135.5	135.5	145.7	109.3	151.9	95.7	130.2	130.2	139.1	106.4	151.6	78.0	124.5	124.5	131.9	103.2	144.2	75.1
	29.4	143.5	143.5	146.2	132.2	159.5	104.4	138.0	138.0	139.6	129.3	152.4	101.1	132.1	132.1	132.4	126.1	144.6	98.0
	32.2	151.2	151.2	146.6	146.6	159.8	126.6	145.6	145.6	140.0	140.0	152.7	123.8	139.3	139.3	132.8	132.8	144.9	120.8
7320	23.9	132.6	118.2	145.5	89.2	141.8	98.8	126.3	115.2	139.7	86.5	145.6	70.7	119.7	111.9	132.3	83.6	144.4	51.7
	26.7	138.3	138.3	147.1	113.4	153.1	99.1	132.8	132.8	140.3	110.4	152.7	80.4	126.9	126.9	133.0	107.2	145.3	77.4
	29.4	146.4	146.4	147.6	137.7	160.7	108.4	140.8	140.8	140.8	134.8	153.5	104.7	134.6	134.6	133.5	131.6	145.6	101.6
	32.2	154.1	154.1	147.9	147.9	160.9	131.7	148.3	148.3	141.2	141.2	153.7	128.9	141.8	141.8	133.9	133.9	145.8	125.9
7790	23.9	133.8	122.6	146.6	92.0	143.1	101.9	127.5	119.5	140.8	89.3	146.6	72.4	120.7	116.2	133.3	86.3	145.2	52.5
	26.7	140.8	140.8	148.3	117.3	152.7	106.8	135.2	135.2	141.4	114.3	153.7	82.8	129.1	129.1	134.0	111.1	146.1	79.8
	29.4	149.0	149.0	148.7	143.3	161.7	111.1	143.2	143.2	141.9	140.3	154.5	108.3	136.8	136.8	134.5	134.5	146.5	105.1
	32.2	156.7	156.7	149.0	149.0	161.9	136.8	150.7	150.7	142.2	142.2	154.7	134.0	144.0	144.0	134.8	134.8	146.7	131.0
L/s		Ent DB °C		Ambient Temperature (°C)															
				46.1															
				Entering Wet Bulb Temperature (°C)															
				16.1		19.4		22.8		16.1		19.4		22.8		16.1		19.4	
TGC SHC		TGC SHC		TGC SHC		TGC SHC		TGC SHC		TGC SHC		TGC SHC		TGC SHC		TGC SHC		TGC SHC	
5900	23.9	108.8	95.3	121.0	72.2	132.6	46.5												
	26.7	113.0	113.0	121.6	91.8	133.5	67.3												
	29.4	120.1	120.1	122.2	111.7	133.9	87.5												
	32.2	127.0	127.0	122.6	122.6	134.3	107.2												
6370	23.9	110.2	99.8	122.3	75.0	133.8	47.3												
	26.7	115.8	115.8	123.0	95.8	134.8	69.7												
	29.4	123.0	123.0	123.5	117.3	135.2	91.1												
	32.2	129.9	129.9	123.9	123.9	135.5	112.5												
6840	23.9	111.5	104.2	123.4	77.8	134.8	48.0												
	26.7	118.3	118.3	124.2	99.9	135.8	72.1												
	29.4	125.6	125.6	124.7	122.8	136.2	94.7												
	32.2	132.5	132.5	125.1	125.1	136.5	117.5												
7320	23.9	112.5	108.5	124.4	80.5	135.6	48.8												
	26.7	120.5	120.5	125.2	103.8	136.7	74.5												
	29.4	127.9	127.9	125.7	125.7	137.1	98.3												
	32.2	134.8	134.8	126.0	126.0	137.3	122.6												
7790	23.9	113.5	112.7	125.3	83.2	136.4	49.5												
	26.7	122.5	122.5	126.1	107.6	137.5	76.8												
	29.4	129.9	129.9	126.5	126.5	137.9	101.7												
	32.2	136.8	136.8	126.9	126.9	138.1	127.7												

**Notes:**

1. All capacities shown are gross and have not considered indoor fan heat. To obtain net cooling, subtract indoor fan heat.
2. TGC = Total gross capacity.
3. SHC = Sensible heat capacity.



## Performance Data (50 Hz Units)

**Table 48. Electric heat air temperature rise (°F) (I-P)—50 Hz**

Heater Input (kW)	Total MBh	CFM										
		7000	8000	9000	10000	11000	12000	13000	14000	15000	16000	17000
26.9	92	12.1	10.6	9.4	8.5	7.7	7.1	—	—	—	—	—
40.4	138	18.2	15.9	14.1	12.7	11.6	10.6	9.8	9.1	8.5	7.9	7.5
53.8	184	24.2	21.2	18.8	16.9	15.4	14.1	13.0	12.1	11.3	10.6	10.0
67.3	230	30.2	26.5	23.5	21.2	19.2	17.6	16.3	15.1	14.1	13.2	12.5
80.7	276	—	—	—	25.4	23.1	21.2	19.5	18.1	16.9	15.9	14.9

**Notes:**

1. Air temperature rise = (kW x 3413)/(scfm x 1.085).
2. All heaters on constant volume units provide 2 increments of capacity.
3. Air temperature rise in this table are based on heater operating at 415 volts.

**Table 49. Electric heat air temperature rise (°C) (SI)—50 Hz**

Heater Input (kW)	L/s										
	3300	3780	4250	4720	5190	5660	6140	6610	7080	7550	8020
26.9	6.8	5.9	5.3	4.7	4.3	4.0	—	—	—	—	—
40.4	10.2	8.9	7.9	7.1	6.5	5.9	5.5	5.1	4.8	4.5	4.2
53.8	13.6	11.9	10.5	9.5	8.6	7.9	7.3	6.8	6.3	5.9	5.6
67.3	17.0	14.8	13.2	11.9	10.8	9.9	9.1	8.5	7.9	7.4	7.0
80.7	—	—	—	14.2	13.0	11.9	11.0	10.2	9.5	8.9	8.4

**Notes:**

1. Air temperature rise in this table are based on heater operating at 415 volts.
2. All heaters on constant volume units provide 2 increments of capacity.

**Table 50. Available electric heat kW ranges—50 Hz**

Nominal Unit Size Tons	Nominal Voltage (V)	
	380	415
22.9	23-56	27-67
25.0	23-56	27-67
29.2	23-56	27-67
33.3	34-68	40-81
42.7	34-68	40-81

**Note:** kW ranges in this table are based on heater operating at nominal voltages 380 or 415.

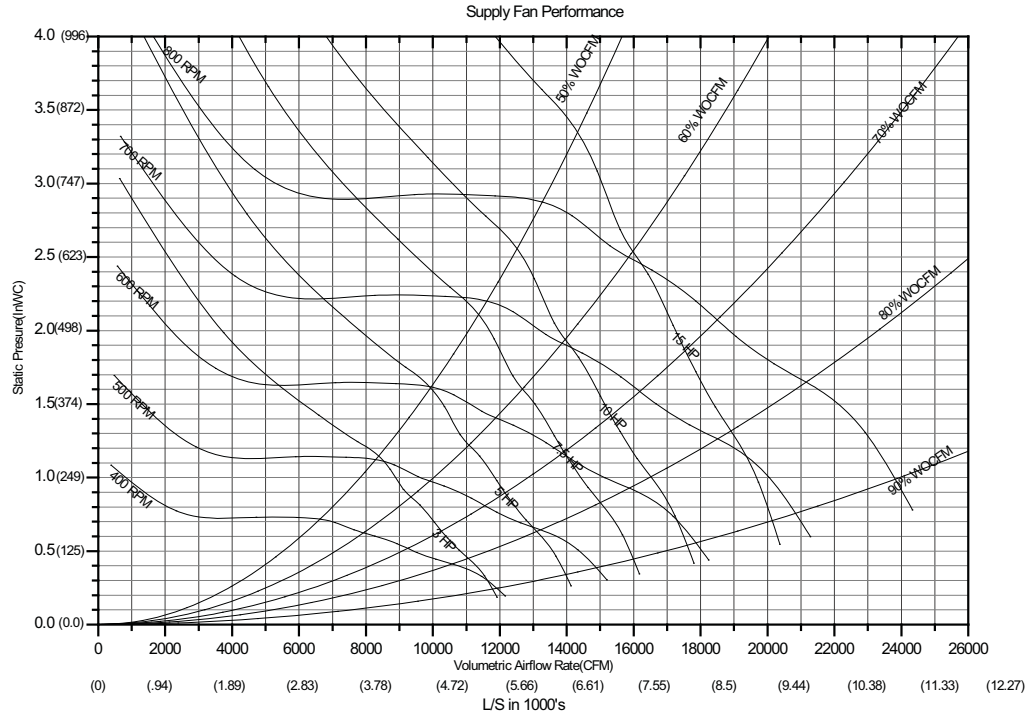
**Table 51. Natural gas heating capacities—50 Hz**

Tons	Unit Model No.	Heat Input MBh (kW)	Heating Output MBh (kW)	Air Temp. Rise, °F (°C)
22.9-29.2	YC(D,H,F,R)275**L	290,000 (85)	232,000 (68)	10-40 (-12.2, 4.4)
	YC(D,H,F,R)300**L			
	YC(D,H,F,R)350**L			
22.9-29.2	YC(D,H,F,R)275**H	500,000 (147)	400,000 (118)	25-55 (-3.9, 12.8)
	YC(D,H,F,R)300**H			
	YC(D,H,F,R)350**H			
33.3-42.7	YC(D,H,F,R)400**L	335,000 (98)	268,000 (78)	5-35 (-15, 1.6)
	YC(D,H,F,R)500**L			
33.3-42.7	YC(D,H,F,R)400**H	670,000 (196)	536,000 (157)	20-50 (-6.7, 10)
	YC(D,H,F,R)500**H			

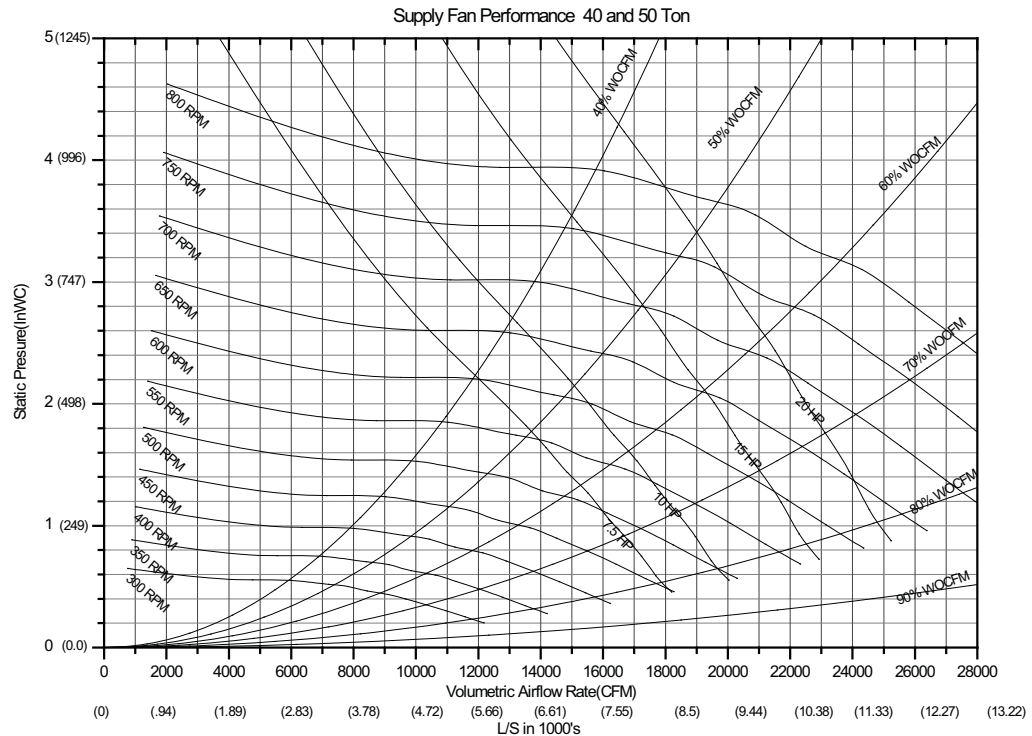
**Note:** Total heating capacity.

## Performance Data (50 Hz Units)

**Figure 7. Supply fan performance — 22.9-29.1 tons**



**Figure 8. Supply fan performance — 33.3 and 41.7 tons (I-P)**



## Performance Data (50 Hz Units)

**Table 52. Component static pressure drops – in. wg (I-P)**

Nominal Std Tons (kW)	CFM Std Air	Heating System				Standard Efficiency ID Coil		High Efficiency ID Coil		Filters				Economizer	Hot Gas Reheat Coil
		Gas Heat		Electric Heat		Dry	Wet	Dry	Wet	Throw-away	MERV 8 High Eff.		MERV 14 High Eff.		
		Low	High	1 Element	2 Elements						2"	2"			
23 (80)	6670	0.07	0.05	0.04	0.05	0.09	0.14	0.12	0.19	0.05	0.08	0.07	0.20	0.331	0.05
	7500	0.08	0.07	0.06	0.06	0.11	0.17	0.14	0.23	0.07	0.11	0.1	0.24	0.04	0.07
	8330	0.1	0.08	0.07	0.08	0.13	0.20	0.17	0.26	0.08	0.13	0.12	0.28	0.049	0.08
	9170	0.13	0.1	0.08	0.09	0.15	0.23	0.20	0.30	0.09	0.15	0.14	0.32	0.059	0.10
	10000	0.15	0.12	0.1	0.11	0.17	0.26	0.23	0.34	0.11	0.18	0.16	0.37	0.07	0.12
25 (88)	7500	0.08	0.07	0.06	0.06	0.11	0.17	0.14	0.23	0.07	0.11	0.1	0.24	0.04	0.07
	8330	0.1	0.08	0.07	0.08	0.13	0.20	0.17	0.26	0.08	0.13	0.12	0.28	0.049	0.08
	9170	0.13	0.1	0.08	0.09	0.15	0.23	0.20	0.30	0.09	0.15	0.14	0.32	0.059	0.10
	10000	0.15	0.12	0.1	0.11	0.17	0.26	0.23	0.34	0.11	0.18	0.17	0.37	0.07	0.12
29 (103)	8750	0.11	0.09	0.08	0.08	0.18	0.28	0.18	0.28	0.09	0.15	0.13	0.30	0.054	0.09
	9580	0.14	0.11	0.09	0.1	0.21	0.32	0.21	0.32	0.1	0.17	0.16	0.34	0.065	0.11
	11200	0.19	0.15	0.13	0.14	0.28	0.41	0.28	0.41	0.12	0.21	0.19	0.43	0.077	0.15
	12100	0.22	0.17	0.15	0.16	0.31	0.46	0.31	0.46	0.13	0.22	0.21	0.48	0.091	0.17
33 (118)	10000	0.01	0.03	0.07	0.11	0.18	0.28	0.22	0.35	0.11	0.18	0.16	0.37	0.070	0.04
	10800	0.01	0.03	0.08	0.13	0.20	0.31	0.25	0.39	0.12	0.21	0.18	0.41	0.076	0.05
	11700	0.01	0.04	0.1	0.15	0.23	0.35	0.29	0.44	0.13	0.23	0.2	0.46	0.085	0.05
	12500	0.01	0.04	0.11	0.17	0.26	0.39	0.32	0.48	0.14	0.26	0.23	0.50	0.096	0.06
	13300	0.02	0.05	0.12	0.19	0.29	0.42	0.36	0.53	0.15	0.28	0.25	0.55	0.107	0.07
	14200	0.02	0.06	0.14	0.22	0.32	0.46	0.40	0.58	0.17	0.32	0.28	0.61	0.12	0.08
42 (146)	12500	0.01	0.04	0.11	0.17	0.33	0.48	0.33	0.48	0.14	0.26	0.23	0.50	0.095	0.06
	13300	0.02	0.05	0.12	0.19	0.36	0.53	0.36	0.53	0.15	0.28	0.25	0.55	0.108	0.07
	14200	0.02	0.06	0.16	0.24	0.40	0.58	0.40	0.58	0.17	0.34	0.29	0.61	0.12	0.08
	15800	0.02	0.07	0.18	0.27	0.48	0.68	0.48	0.68	0.19	0.38	0.34	0.71	0.136	0.10
	16700	0.03	0.08	0.2	0.3	0.53	0.74	0.53	0.74	0.2	0.41	0.36	0.77	0.155	0.11

**Note:** Static pressure drops of accessory components must be added to external static pressure to enter fan performance tables.



## Performance Data (50 Hz Units)

**Table 53. Supply air fan drive selections**

Nominal Tons (kW)	7.5 hp (5.6 kW)		10 hp (7.5 kW)		15 hp (10 kW)		20 hp (15 kW)	
	rpm	Drive No	rpm	Drive No	rpm	Drive No	rpm	Drive No
23 (80)	458	A	—	—	—	—	—	—
	500	B	—	—	—	—	—	—
	541	C	—	—	—	—	—	—
	583	—	583	D	—	—	—	—
	625	—	625 <sup>1</sup>	E	—	—	—	—
25 (88)	458	A	—	—	—	—	—	—
	500	B	—	—	—	—	—	—
	541	C	—	—	—	—	—	—
	583	—	583	D	—	—	—	—
	625	—	625	E	—	—	—	—
29 (103)	500	B	—	—	—	—	—	—
	541	—	541	C	—	—	—	—
	583	—	583	D	—	—	—	—
	658	—	—	—	658 <sup>2</sup>	F	—	—
	664	—	—	—	664 <sup>1</sup>	G	—	—
33 (118)	417	—	417	H	—	—	—	—
	437	—	437	J	—	—	—	—
	479	—	479	K	—	—	—	—
	521	—	—	—	521	L	—	—
	562	—	—	—	562	M	—	—
	604	—	—	—	604	N	—	—
42 (146)	437	—	437	J	—	—	—	—
	479	—	479	K	—	—	—	—
	521	—	—	—	521	L	—	—
	562	—	—	—	562	M	—	—
	604	—	—	—	—	—	604	N

1. For YC gas/electrics only.
2. For TC and TE Cooling only and with electric Heat units only.

**Table 54. Power exhaust fan performance—22.9 - 29.2 tons—50 Hz**

Return Duct Static (Pa)	Power Exhaust Selection			
	50%		100%	
	Damper Open Position			
	min	max	min	max
	L/s			
0.0	1499	2701	2999	5405
24.9	1375	2083	2751	4166
49.8	1255	1753	2488	3540
74.7	1134	1499	2269	3003
99.6	1031	1321	2061	2643
124.5	921	1135	1842	2270

**Table 55. Power exhaust fan performance—33.3 - 41.7 tons—50 Hz**

	Power Exhaust Selection			
	50%		100%	
	Damper Open Position			
	min	max	min	max
Return Duct Static (Pa)	L/S			
0.0	1909	3160	3818	6321
24.9	1800	2915	3599	5829
49.8	1676	2537	3364	5308
74.7	1577	2371	3155	4741
99.6	1462	2173	2925	4347
124.5	1364	2040	2727	4080

**Note:** These values are the minimum and maximum positions for non-tracking power exhaust. Fresh air tracking and Statitrac options can fully close the exhaust dampers in their operation, and are thus able to reach lower airflows. Statitrac requires 100% power exhaust.



# Controls

## VAV Units Only—Sequence of Operation

### Supply Air Pressure Control

#### Variable Frequency Drives (VFD) Control

Variable frequency drives are driven by a modulating 0-10 Vdc signal from the VAV module. A pressure transducer measures duct static pressure, and the VFD is modulated to maintain the supply air static pressure within an adjustable user-defined range. The range is determined by the supply air pressure setpoint and supply air pressure deadband, which are set through a unit mounted potentiometer. Variable frequency drives provide supply fan motor speed modulation. The drive will accelerate or decelerate as required to maintain the supply static pressure setpoint. When subjected to high ambient return conditions the VFD shall reduce its output frequency to maintain operation. Bypass control is offered to provide full nominal airflow in the event of drive failure.

#### Supply Air Static Pressure Limit

The control of the VFD and VAV boxes are coordinated, with respect to time, during unit start up and transition to/from Occupied/Unoccupied modes to prevent overpressurization of the supply air ductwork. However, if for any reason the supply air pressure exceeds the fixed supply air static pressure limit of 3.5" W.C., the supply fan is shut down and the VAV boxes are closed. The unit is then allowed to restart three times. If the overpressurization condition occurs on the fourth time, the unit is shut down and a manual reset diagnostic is set and displayed at any of the remote panels with LED status lights or communicated to the Integrated Comfort system.

### Supply Air Temperature Controls

#### Cooling/Economizer

During occupied cooling mode of operation, the economizer (if available) and primary cooling are used to control the supply air temperature. The supply air temperature setpoint is user-defined at the unit mounted VAV Setpoint Potentiometer or at the remote panel. If the enthalpy of the outside air is appropriate to use "free cooling," the economizer will be used first to attempt to satisfy the supply setpoint.

On units with economizer, a call for cooling will modulate the fresh air dampers open. The rate of economizer modulation is based on deviation of the discharge temperature from setpoint, i.e., the further away from setpoint, the faster the fresh air damper will open. Note that the economizer is only allowed to function freely if ambient conditions are below the enthalpy control setting or below the return air enthalpy if unit has comparative enthalpy installed. If outside air is not suitable for "economizing," the fresh air dampers drive to the minimum open position. A field adjustable potentiometer on the Economizer Actuator, Tracer™, or a remote potentiometer can provide the input to establish the minimum damper position.

At outdoor air conditions above the enthalpy control setting, primary cooling only is used and the fresh air dampers remain at minimum position.

If the unit does not include an economizer, primary cooling only is used to satisfy cooling requirements.

#### Supply Air Setpoint Reset

Supply air reset can be used to adjust the supply air temperature setpoint on the basis of a zone temperature, return air temperature, or on outdoor air temperature. Supply air reset adjustment is available on the unit mounted VAV Setpoint Potentiometer for supply air cooling control.

#### Reset Based on Outdoor Air Temperature

Outdoor air cooling reset is sometimes used in applications where the outdoor temperature has a large effect on building load. When the outside air temperature is low and the building cooling load is low, the supply air setpoint can be raised, thereby preventing subcooling of critical zones.

This reset can lower usage of primary cooling and result in a reduction in primary cooling energy usage.

There are two user-defined parameters that are adjustable through the VAV Setpoint Potentiometer: reset temperature setpoint and reset amount. The amount of reset applied is dependent upon how far the outdoor air temperature is below the supply air reset setpoint. The amount is zero where they are equal and increases linearly toward the value set at the reset amount input. The maximum value is 20°F. If the outdoor air temperature is more than 20°F below the reset temperature setpoint the amount of reset is equal to the reset amount setpoint.

### **Reset Based on Zone or Return Temperature**

Zone or return reset is applied to the zone(s) in a building that tend to overcool or overheat. The supply air temperature setpoint is adjusted based on the temperature of the critical zone(s) or the return air temperature. This can have the effect of improving comfort and/or lowering energy usage. The user-defined parameters are the same as for outdoor air reset.

Logic for zone or return reset control is the same except that the origins of the temperature inputs are the zone sensor or return sensor respectively. The amount of reset applied is dependent upon how far the zone or return air temperature is below the supply air reset setpoint. The amount is zero where they are equal and increases linearly toward the value set at the reset amount potentiometer on the VAV Setpoint potentiometer. The maximum value is 3°F. If the return or zone temperature is more than 3°F below the reset temperature setpoint the amount of reset is equal to the reset amount setpoint.

### **VAV Supply Air Tempering (Only Available with Modulating Gas Heat)**

Gas heat will be modulated to prevent the Discharge Air Temperature from falling below the Discharge Air Temperature Deadband. Upon satisfying the Supply Air Tempering requirements a five-minute 'SA Tempering Delay' timer will start whenever the modulating heat is commanded to 0% and must time out before the unit will be allowed to re-enter "Cool" mode. This timer will be reset to 5 minutes whenever there is an active call for heat to meet Supply Air Tempering demands.

Tempering will be discontinued whenever:

- The five-minute 'SA Tempering Delay' timer has timed-out and
- there is an active cooling request for VAV Occupied Cooling

## **Zone Temperature Control**

### **Unoccupied Zone Heating and Cooling**

During Unoccupied mode, the unit is operated as a CV unit. VAV boxes are driven full open and the VFD is commanded to full speed. The unit controls zone temperature to the Unoccupied zone cooling and heating (heating units only) setpoints.

### **Daytime Warm-up**

During occupied mode, if the zone temperature falls to a temperature three degrees below the Morning Warm-up setpoint, Daytime Warm-up is initiated. The system changes to CV heating (full unit airflow), the VAV boxes are fully opened and the CV heating algorithm is in control until the Morning Warm-up setpoint is reached. The unit is then returned to VAV cooling mode. The Morning Warm-up setpoint is set at the unit mounted VAV Setpoint potentiometer or at a remote panel.

### **Morning Warm-up (MWU)**

Morning warm-up control (MWU) is activated whenever the unit switches from unoccupied to occupied and the zone temperature is at least 1.5°F below the MWU setpoint. When MWU is activated the VAV box output will be energized for at least 6 minutes to drive all boxes open, the VFD is commanded to full speed, and full heat (gas or electric) is energized. When MWU is activated the economizer damper is driven fully closed. When the zone temperature meets or exceeds the MWU setpoint minus 1.5°F, the heat will be turned or staged down. When the zone temperature

meets or exceeds the MWU setpoint then MWU will be terminated and the unit will switch over to VAV cooling.

## CV Units Only—Sequence of Operation

### Occupied Zone Temperature Control

#### Cooling/Economizer

During occupied cooling mode, the economizer (if provided) and primary cooling are used to control zone temperature. If the enthalpy of outside air is appropriate to use “free cooling,” the economizer will be used first to attempt to satisfy the cooling zone temperature setpoint; then primary cooling will be staged up as necessary.

On units with economizer, a call for cooling will modulate the fresh air dampers open. The rate of economizer modulation is based on deviation of the zone temperature from setpoint, i.e., the further away from setpoint, the faster the fresh air damper will open. First stage of cooling will be allowed to start after the economizer reaches full open.

**Note:** *The economizer is allowed to function freely only if ambient conditions are below the enthalpy control setting or below the return air enthalpy if unit has comparative enthalpy. If outside air is not suitable for “economizing,” the fresh air dampers drive to the minimum open position. A field adjustable potentiometer on the Economizer Actuator, a communicated value through Tracer, or a remote potentiometer can provide the input to establish the minimum damper position.*

At outdoor air temperatures above the enthalpy control setting, primary cooling only is used and the outdoor air dampers remain at minimum position.

If the unit does not include an economizer, primary cooling only is used to satisfy cooling requirements.

#### Gas Heating

When heating is required the RTRM initiates the heating cycle through the ignition control module(s) (IGN). The IGN relay brings on the combustion fan motor. The ignition control module(s) begin the ignition process by preheating the hot surface ignitor(s). After the hot surface ignitor is preheated the gas valve is opened to ignite first stage. If ignition does not take place the IGN(s) will attempt to ignite 2 more times before locking out. When ignition does occur the hot surface ignitor is deenergized and then functions as a flame sensor. The RTRM will energize the supply fan contactor 45 seconds after the initiation of the heat cycle. If more capacity is needed to satisfy the heating setpoint, the RTRM will call for more heat by driving the combustion blower motor to high speed.

When the space temperature rises above the heating setpoint, the RTRM terminates the heat cycle.

#### Electric Heating

When heat is required, the RTRM initiates first stage heating by energizing the first stage electric heat contactor. The first stage electric heater bank(s) will be energized if the appropriate limits are closed. The RTRM will cycle first stage heat on and off as required to maintain zone temperature. If first stage cannot satisfy the requirement, the RTRM will energize the second stage electric heat contactor(s) if the appropriate limits are closed. The RTRM will cycle second stage on and off as required while keeping stage one energized.

The supply fan is energized approximately 1 second before the electric heat contactors. When the space temperature rises above the heating setpoint, the RTRM deenergizes the supply fan and all electric heat contactors.

#### Supply Air Tempering - Staged Heat

For CV units configured with a Staged Heat design (Electric or Gas) and the Supply Air Tempering operation is enabled, if the following items are true, the unit will enter Supply Air Tempering mode:



- The supply fan is ON.
- The unit is in Occupied mode.
- Zone Temp. is less than the active Cooling setpoint.
- The unit is in Heat mode but is not actively heating OR
- The unit is in AUTO-COOL mode but not actively cooling and cooling capacity has been OFF for 5 minutes.

Once the above conditions are met, if the supply air temperature drops to 10°F BELOW the Occupied Heating Zone Temperature Setpoint, the SA Tempering function will bring ON one stage of gas or electric heat.

Once SA Tempering is active, heating will be turned OFF if the Supply Air Temperature rises to 10°F ABOVE the Active Occupied Zone Heating Setpoint, or the Zone Temperature rises to the Active Zone Cooling Setpoint. Also, if the Zone Heat Control function is calling for 1 or more stages of Heat, Tempering will be discontinued and the unit will stage additional heating to meet the current demand.

### **Supply Air Tempering - Modulating Heat**

On units with Modulating Gas Heat, Supply Air Tempering is inherent to the Modulating Heat design and does not require any additional configuration/enabling. Modulating Heat Tempering is accomplished by allowing the unit to return to heating if the zone is marginally satisfied and the discharge air temperature begins to fall. The following conditions must be true to enable the unit to perform "Tempering":

- The supply fan is ON.
- The unit is in Occupied mode.
- Zone Temp. is less than the active Cooling setpoint.
- The unit is in Heat mode but is not actively heating OR
- The unit is in AUTO-COOL mode but not actively cooling and cooling capacity has been OFF for 5 minutes.

Once the above conditions are met, and the supply air temperature drops below the ZHSP - 10°F, the unit will transition back into active heating operation and will begin to control the modulating heat output to maintain the supply air temperature.

Once the unit has entered into Tempering mode, the unit will leave active heating either by normal heat termination as determined by the heating control algorithm or when the Zone Temperature reaches the active ZCSP.

### **Auto Changeover**

When the System Mode is "Auto," the mode will change to cooling or heating as necessary to satisfy the zone cooling and heating setpoints. The zone cooling and heating setpoints can be as close as 2°F apart.

## **Unoccupied Zone Temperature Control Cooling and Heating**

Both cooling or heating modes can be selected to maintain Unoccupied zone temperature setpoints. For Unoccupied periods, heating or primary cooling operation can be selectively locked out at the remote panels or TRACER.

### **Conventional Thermostat Interface**

Conventional Thermostat Interface (CTI) is a standard part of the RTRM. The CTI will allow only two steps of heating or cooling. The CTI provides zone temperature control only and is mutually exclusive of the Trane Communications Interface (TCI).

**Note:** *If a conventional thermostat is used with a unit that has modulating gas heat, the heat will not perform as intended).*

## Single Zone VAV Units Only (SZ VAV)—Sequence of Operation

### Zone Temperature Control

#### Variable Frequency Drives (VFD) Control

A Variable frequency drive is used to provide supply fan motor speed modulation. For SZ VAV the VFD is driven by a modulating 0-10Vdc signal from the Options module. For SZ VAV control, the drive will accelerate or decelerate as required to meet the Zone Heating (Modulating Heat Only) or Cooling demand. In order to maximize energy savings, the VFD will be held at minimum speed until the load in the zone requires the speed to increase.

**Note:** *To enhance unit performance, the minimum VFD speed is modified based on unit function (Heating, Cooling, Ventilation Only).*

#### Cooling Operation (DX and Economizer)

During active cooling mode, the economizer (if provided) and primary cooling are used to control the discharge air temperature to a calculated discharge air temperature setpoint. The calculated discharge air setpoint is based on the zone cooling demand and its upper and lower limits will be customer selectable through potentiometers located on the Options module or through a BAS. If available cooling capacity (economizer and DX cooling) is not sufficient to meet the load demands in the space, the supply fan motor speed will be modulated in order to meet the load. If the enthalpy of outside air is appropriate to use “free cooling,” the economizer will be used first to attempt to satisfy the cooling zone temperature setpoint (as on a traditional CV unit); then primary cooling will be staged up as necessary.

On units with an economizer, a call for cooling will modulate the fresh air dampers open. The rate of economizer modulation is based on deviation of the zone temperature from setpoint: the further away from setpoint, the faster the fresh air damper will open. First stage of cooling will be allowed to start after the economizer reaches full open. Once compressors are staged to meet the zone demand, the economizer position will be held full open, as long as the economizer remains enthalpy enabled, to ensure the maximum cooling capacity of the economizer is being utilized.

**Note:** *The economizer is allowed to function freely only if ambient conditions are below the enthalpy control setting or below the return air enthalpy if unit has comparative enthalpy as on traditional CV and VAV units. If outside air is not suitable for “economizing,” the fresh air dampers drive to the active minimum open position. Field adjustable potentiometers on the Economizer Actuator, a communicated value through Tracer, or a remote potentiometer can provide the input to establish the minimum damper position.*

If outside air temperatures are not favorable for economizer operation, primary cooling only is used and the outdoor air dampers remain at minimum position.

If the unit does not include an economizer, primary cooling only is used to satisfy cooling requirements.

### Heating Operation

Units with SZ VAV control will operate heat utilizing two different schemes based on the installed heating type; Staged or Modulating.

#### Staged Heat

Units configured with Staged Heat (all Electric and Staged Gas) will perform Heating utilizing the traditional CV Heating control schemes with full airflow from the VFD controlled supply fan. No other changes in heating operation are implemented for Staged Heating types - all Gas and Electric Heat staging will remain consistent with CV units.

#### Modulating Heat

Units configured with Modulating Gas Heat will also benefit from supply fan speed modulation to meet the heating demands of the zone, similarly to during active Cooling operation. During active

heating mode, the modulating heat output is commanded to control the discharge air temperature to a calculated discharge air temperature setpoint. The calculated discharge air setpoint is based on the zone heating demand and its upper and lower limits will be customer selectable through potentiometers located on the Options module. If available heating capacity is not sufficient to meet the load demands in the space, the supply fan motor speed will be modulated in order to meet the load. Note that Gas Heat ignition sequences will be consistent with traditional CV units as well as all applicable protection schemes.

## **Supply Air Tempering**

Units with SZ VAV control will operate Supply Air Tempering utilizing two different schemes based on the installed heating type; Staged or Modulating.

### **Staged Heat**

Units configured with Staged Heat (all Electric and Staged Gas) will perform Supply Air Tempering utilizing the traditional CV Supply Air Tempering control scheme with full airflow from the VFD controlled supply fan.

### **Modulating Heat**

Units configured with Modulating Gas Heat will perform Tempering as an extension of normal Heating control. When the following conditions are met, the unit will enter into a “Tempering” mode:

- Supply Fan is ON.
- The unit is in Occupied mode.
- The unit is operating in Auto-Cool Mode.
- Cooling has been inactive for 5 minutes.
- Zone Temperature is less than ZCSP - 1°F.

If the above conditions are met and the discharge air temperature falls below the user configurable Discharge Air Cool Low Limit setpoint, the unit will begin to control the modulating heat output to maintain the discharge air temperature requirements. Note that Tempering within a modulating heat unit is inherent to the Modulating Heat control design and does not require any additional configuration - it is an extension of normal Heating control.

## **Auto Changeover**

When the System Mode is “Auto”; the mode will change to cooling or heating as necessary to satisfy the zone cooling and heating setpoints as on a CV unit. The zone cooling and heating setpoints can be as close as 2°F apart.

## **Unoccupied Zone Temperature Control Cooling and Heating**

Unoccupied Heating and Cooling operation will be controlled as during normal Occupied operation but will utilize the Unoccupied Heating and Cooling setpoints as on a CV unit.

## **Conventional Thermostat Interface**

Single Zone VAV control is not available utilizing the Conventional Thermostat Interface; a zone sensor is required for Single Zone VAV operation.

## Control Sequences of Operation Common to CV, VAV, and SZ VAV

### Ventilation Override (VOM)

Applying 24 volts to one of the three Ventilation Override inputs manually activates ventilation override. One input is provided to request the pressurize mode, the second input to request the purge mode, and the third input to request the exhaust mode.

**Note:** Ventilation override exhaust mode is not available for the exhaust fan with fresh air tracking power exhaust. VOM is available for the exhaust fan **without** fresh air tracking power exhaust.

If more than one mode is requested at the same time, the pressurize request will have priority followed by purge. When any ventilation override mode is active, all heating and cooling is turned off. For the case where the unit is required to turn off, the emergency stop input is used. The ICS can also initiate any ventilation override mode.

**Table 56. Mode and priority**

Affected Function	Mode and Priority		
	Pressurize 1	Purge 2	Exhaust 3
Heat/Cool	off	off	off
VFD	full speed	full speed	full speed
Supply Fan	on	on	off
Exhaust Fan	off	on	n/a <sup>(a)</sup>
Economizer	open	open	closed
VAV Boxes	forced open	forced open	normal operation

(a) Ventilation override exhaust mode is not available for the exhaust fan with fresh air tracking power exhaust. VOM is available for the exhaust fan **without** fresh air tracking power exhaust.

### Coil Freeze Protection Frostat™

The Frostat system eliminates the need for hot gas bypass and adds a suction line surface temperature sensor to determine if the coil is in a condition of impending frost. If impending frost is detected primary cooling capacity is shed as necessary to prevent icing. All compressors are turned off after they have met their minimum 3 minute on times. The supply fan is forced on until the Frostat device no longer senses a frosting condition or for 60 seconds after the last compressor is shut off, whichever is longer.

### Occupied/Unoccupied Switching

There are 3 ways to switch Occupied/Unoccupied:

- NSB Panel
- Electronic time clock or field-supplied contact closure
- TRACER

### Space Pressure Control - Statitrac™

A pressure transducer is used to measure and report direct space (building) static pressure. The user-defined control parameters used in this control scheme are space static pressure set point and deadband. As the economizer opens, the building pressure rises and enables the exhaust fan and dampers. The exhaust dampers then modulate to maintain space pressure within the deadband.

### Night Setback Sensors

Trane's night setback sensors are programmable with a time clock function that provides communication to the rooftop unit through a 2-wire communications link. The desired transition times are programmed at the night setback sensor and communicated to the unit.

Night setback (unoccupied mode) is operated through the time clock provided in the sensors with night setback. When the time clock switches to night setback operation, the outdoor air dampers close and heating/cooling can be enabled or disabled. As the building load changes, the night setback sensor communicates the need for the rooftop heating/cooling (if enabled) function and the evaporator fan. The rooftop unit will cycle through the evening as heating/cooling (if enabled) is required in the space. When the time clock switches from night setback to occupied mode, all heating/cooling functions begin normal operation.

When using the night setback options with a VAV heating/cooling rooftop, airflow must be maintained through the rooftop unit. This can be accomplished by electrically tying the VAV boxes to the VAV heat relay contacts on the low voltage terminal board or by using changeover thermostats. Either of these methods will assure adequate airflow through the unit and satisfactory temperature control of the building.

### **Timed Override Activation—ICS**

When this function is initiated by pushing the override button on the ICS sensor, TRACER will switch the unit to the occupied mode. Unit operation (occupied mode) during timed override is terminated by a signal from TRACER or through pushing the override cancel button on the ICS sensor.

### **Timed Override Activation—Non-ICS**

When this function is initiated by the push of an override button on the programmable zone sensor, the unit will switch to the occupied mode. Automatic Cancellation of the Timed override Mode occurs after three hours of operation or through cancellation of timed override through the programmable zone sensor interface.

### **Comparative Enthalpy Control of Economizer**

The Economizer Actuator receives inputs from optional return air humidity and temperature sensors and determines whether or not it is feasible to economize. If the outdoor air enthalpy is greater than the return air enthalpy, it is not feasible to economize and the economizer damper will not open past its minimum position.

### **Fan Failure Switch**

The fan failure switch will disable all unit functions and “flash” the Service LED on the zone sensor.

### **Emergency Stop Input**

A binary input is provided on the RTRM for installation of field provided switch or contacts for immediate shutdown of all unit functions. The binary input is brought out to Low Voltage Terminal Board One (LTB1).

### **Condensate Overflow Switch**

This option shall shut the unit down in the event that a clogged condensate drain line prevents proper condensate removal from the unit.



# Electrical Data

## Electrical Service Sizing

To correctly size electrical service wiring for your unit, find the appropriate calculations listed below. Each type of unit has its own set of calculations for MCA (Minimum Circuit Ampacity), MOP (Maximum Overcurrent Protection), and RDE (Recommended Dual Element fuse size). Read the load definitions that follow and then find the appropriate set of calculations based on your unit type.

Set 1 is for cooling only and cooling with gas heat units, and set 2 is for cooling with electric heat units.

Load Definitions: (To determine load values, see the Electrical Service Sizing Data Tables.)

LOAD1 = CURRENT OF THE LARGEST MOTOR (COMPRESSOR OR FAN MOTOR)

LOAD2 = SUM OF THE CURRENTS OF ALL REMAINING MOTORS

LOAD3 = CURRENT OF ELECTRIC HEATERS

LOAD4 = ANY OTHER LOAD RATED AT 1 AMP OR MORE

### Set 1. Cooling Only Rooftop Units and Cooling with Gas Heat Rooftop Units

$$\text{MCA} = (1.25 \times \text{LOAD1}) + \text{LOAD2} + \text{LOAD4}$$

$$\text{MOP} = (2.25 \times \text{LOAD1}) + \text{LOAD2} + \text{LOAD4}$$

Select a fuse rating equal to the MOP value. If the MOP value does not equal a standard fuse size as listed in NEC 240-6, select the next lower standard fuse rating. NOTE: If selected MOP is less than the MCA, then reselect the lowest standard maximum fuse size which is equal to or larger than the MCA, provided the reselected fuse size does not exceed 800 amps.

$$\text{RDE} = (1.5 \times \text{LOAD1}) + \text{LOAD2} + \text{LOAD4}$$

Select a fuse rating equal to the RDE value. If the RDE value does not equal a standard fuse size as listed in NEC 240-6, select the next higher standard fuse rating.

**Note:** If the selected RDE is greater than the selected MOP value, then reselect the RDE value to equal the MOP value.

(Keep in mind when determining LOADS that crankcase heaters are disabled in the cooling mode.)

$$\text{DSS} = 1.15 \times (\text{LOAD1} + \text{LOAD2} + \text{LOAD4})$$

Select a disconnect switch size equal to or larger than the DSS value calculated.

### Set 2. Rooftop Units with Electric Heat

To arrive at the correct MCA, MOP, and RDE values for these units, you must perform two sets of calculations. First calculate the MCA, MOP, and RDE values as if the unit was in cooling mode (use the equations given in Set 1). Then calculate the MCA, MOP, and RDE values as if the unit was in the heating mode as follows.

(Keep in mind when determining LOADS that the compressors and condenser fans don't run while the unit is in the heating mode and crankcase heaters are disabled in the cooling mode.)

For units using heaters less than 50 kw.

$$\text{MCA} = 1.25 \times (\text{LOAD1} + \text{LOAD2} + \text{LOAD4}) + (1.25 \times \text{LOAD3})$$

For units using heaters equal to or greater than 50 kw.

$$\text{MCA} = 1.25 \times (\text{LOAD1} + \text{LOAD2} + \text{LOAD4}) + \text{LOAD3}$$

The nameplate MCA value will be the larger of the cooling mode MCA value or the heating mode MCA value calculated above.

$$\text{MOP} = (2.25 \times \text{LOAD1}) + \text{LOAD2} + \text{LOAD3} + \text{LOAD4}$$

The selection MOP value will be the larger of the cooling mode MOP value or the heating mode MOP value calculated above.

Select a fuse rating equal to the MOP value. If the MOP value does not equal a standard fuse size as listed in NEC 240-6, select the next lower standard fuse rating.

**Note:** If selected MOP is less than the MCA, then reselect the lowest standard maximum fuse size which is equal to or larger than the MCA, provided the reselected fuse size does not exceed 800 amps.

$$RDE = (1.5 \times \text{LOAD1}) + \text{LOAD2} + \text{LOAD3} + \text{LOAD4}$$

The selection RDE value will be the larger of the cooling mode RDE value or the heating mode RDE value calculated above.

Select a fuse rating equal to the RDE value. If the RDE value does not equal a standard fuse size as listed in NEC 240-6, select the next higher standard fuse rating.

**Note:** If the selected RDE is greater than the selected MOP value, then reselect the RDE value to equal the MOP value.

$$DSS = 1.15 \times (\text{LOAD1} + \text{LOAD2} + \text{LOAD3} + \text{LOAD4})$$

**Note:** Keep in mind when determining LOADS that the compressors and condenser fans don't run while the unit is in the heating mode.

The selection DSS value will be the larger of the cooling mode DSS or the heating mode DSS calculated above.

Select a disconnect switch size equal to or larger than the DSS value calculated.

**Table 57. 27½-50 ton electrical service sizing data—60Hz**

Model	Electrical Characteristics	Allowable Voltage Range	Fan Motors														
			Compressor - Std Efficiency			Compressor - High Efficiency, eStage			Supply		Condenser			Exhaust			
			No/ Ton	RLA (Ea.)	LRA (Ea.)	No/ Ton	RLA (Ea.)	LRA (Ea.)	HP	FLA	No	HP	FLA (Ea.)	50 % No.	100 % <sup>(a)</sup>	HP	FLA (Ea.)
TC/TE/ YC*330	208/60/3	187-229	1/12, 1/13	44.0/ 50.5	304/ 315	1/6, 2/9	28.0, 37.1	203, 267	7.5 10.0	22.2 29.5	3	1.1	7.0	1	2	1.0	4.1
	230/60/3	207-253	1/12, 1/13	44.0/ 50.5	304/ 315	1/6, 2/9	28.0, 37.1	203, 267	7.5 10.0	18.8 25.2	3	1.1	7.0	1	2	1.0	4.1
	460/60/3	414-506	1/12, 1/13	21.0/ 23.0	147/ 158	1/6, 2/9	14.1, 16.8	98, 142	7.5 10.0	9.4 12.6	3	1.1	3.5	1	2	1.0	1.8
	575/60/3	517-633	1/12, 1/13	17.5/ 19.0	122/ 136	1/6, 2/9	12.2, 14.7	84, 103	7.5 10.0	7.8 10.1	3	1.1	2.8	1	2	1.0	1.4
TC/TE/ YC*360	208/60/3	187-229	2/13	50.5	315/ 315	1/6, 2/10	28.0, 40.9	203, 267	7.5 10.0 15.0	22.2 29.5 40.7	3	1.1	7.0	1	2	1.0	4.1
	230/60/3	207-253	2/13	50.5	315/ 315	1/6, 2/10	28.0, 40.9	203, 267	7.5 10.0 15.0	18.8 25.2 35.4	3	1.1	7.0	1	2	1.0	4.1
	460/60/3	414-506	2/13	23.0	158/ 158	1/6, 2/10	14.1, 18.6	98, 142	7.5 10.0 15.0	9.4 12.6 17.7	3	1.1	3.5	1	2	1.0	1.8
	575/60/3	517-633	2/13	19.0	136/ 136	1/6, 2/10	12.2, 15.4	84, 103	7.5 10.0 15.0	7.8 10.1 15.1	3	1.1	2.8	1	2	1.0	1.4



## Electrical Data

**Table 57. 27½-50 ton electrical service sizing data—60Hz**

Model	Electrical Characteristics	Allowable Voltage Range	Fan Motors														
			Compressor - Std Efficiency			Compressor - High Efficiency, eStage			Supply		Condenser			Exhaust			
			No/ Ton	RLA (Ea.)	LRA (Ea.)	No/ Ton	RLA (Ea.)	LRA (Ea.)	HP	FLA	No	HP	FLA (Ea.)	50 % No.	100 % <sup>(a)</sup> No.	HP	FLA (Ea.)
TC/TE/ YC*420	208/60/3	187-229	1/13, 1/15	50.5/ 56.0	315/ 351	1/6, 2/11	28.0, 44.9	203, 304	7.5 10.0 15.0	22.2 29.5 40.7	3	1.1	7.0	1	2	1.0	4.1
	230/60/3	207-253	1/13, 1/15	50.5/ 56.0	315/ 351	1/6, 2/11	28.0, 44.9	203, 304	7.5 10.0 15.0	18.8 25.2 35.4	3	1.1	7.0	1	2	1.0	4.1
	460/60/3	414-506	1/13, 1/15	23.0/ 27.5	158/ 197	1/6, 2/11	14.1, 19.2	98, 147	7.5 10.0 15.0	9.4 12.6 17.7	3	1.1	3.5	1	2	1.0	1.8
	575/60/3	517-633	1/13, 1/15	19.0/ 23.0	136/ 146	1/6, 2/11	12.2, 16.6	84, 122	7.5 10.0 15.0	7.8 10.1 15.1	3	1.1	2.8	1	2	1.0	1.4
TC/TE/ YC*480	208/60/3	187-229	1/13, 1/20	50.5/ 83.9	315/ 485	1/8, 2/13	31.1, 50.5	203, 315	10.0 15.0	29.5 40.7	4	1.1	7.0	1	2	1.5	5.4
	230/60/3	207-253	1/13, 1/20	50.5/ 83.9	315/ 485	1/8, 2/13	31.1, 50.5	203, 315	10.0 15.0	25.2 35.4	4	1.1	7.0	1	2	1.5	5.4
	460/60/3	414-506	1/13, 1/20	23.0/ 34.0	158/ 215	1/8, 2/13	14.1, 23.0	98, 158	10.0 15.0	12.6 17.7	4	1.1	3.5	1	2	1.5	2.7
	575/60/3	517-633	1/13, 1/20	19.0/ 27.3	136/ 175	1/8, 2/13	11.5, 19.0	84, 136	10.0 15.0	10.1 15.1	4	1.1	2.8	1	2	1.5	2.2
TC/TE/ YC*600	208/60/3	187-229	2/13, 1/15	50.5/ 56.0	315/ 351	1/10, 2/15	40.9, 58.5	267, 351	10.0 15.0 20.0	29.5 40.7 56.1	4	1.1	7.0	1	2	1.5	5.4
	230/60/3	207-253	2/13, 1/15	50.5/ 56.0	315/ 351	1/10, 2/15	40.9, 58.5	267, 351	10.0 15.0 20.0	25.2 35.4 49.4	4	1.1	7.0	1	2	1.5	5.4
	460/60/3	414-506	2/13, 1/15	23.0/ 27.5	158/ 197	1/10, 2/15	18.6, 27.5	142, 197	10.0 15.0 20.0	12.6 17.7 24.7	4	1.1	3.5	1	2	1.5	2.7
	575/60/3	517-633	2/13, 1/15	19.0/ 23.0	136/ 146	1/10, 2/15	15.4, 23.0	103, 135	10.0 15.0 20.0	10.1 15.1 19.6	4	1.1	2.8	1	2	1.5	2.2

**Note:** All customer wiring and devices must be installed in accordance with local and national electrical codes.

(a) 100% Power Exhaust is with or without Statitrac™.

**Table 58. Electrical service sizing data—crankcase heaters—(heating mode only)—60Hz**

Nominal Unit Size (Tons)	FLA Add Unit Voltage			
	200	230	460	575
27½ - 35	1	1	1	1
40, 50	2	2	1	1



**Table 59. Electrical service sizing data — electric heat module (electric heat only)—60Hz**

Models: TE(D,H,F,R) 330–600 Electric Heat FLA						
Nominal Unit Size (Tons)	Nominal Unit Voltage	KW Heater				
		36 FLA	54 FLA	72 FLA	90 FLA	108 FLA
27½-35	208	74.9	112.4	—	—	—
	230	86.6	129.9	—	—	—
	460	43.3	65.0	86.6	108.3	—
	575	—	52.0	69.3	86.6	—
40- 50	208	—	112.4	—	—	—
	230	—	129.9	—	—	—
	460	—	65.0	86.6	108.3	129.9
	575	—	52.0	69.3	86.6	103.9

**Note:** All FLA in this table are based on heater operating at 208, 240, 480, and 600 volts.

**Table 60. Electrical service sizing data — 50Hz**

Model	Electrical Characteristics	Compressor - Std Efficiency			Compressor - High Efficiency			Fan Motors								
		No/ Ton	RLA (Ea.)	LRA (Ea.)	No/ Ton	RLA (Ea.)	LRA (Ea.)	Supply		Condenser <sup>(a)</sup>			Exhaust			
								HP (kW)	FLA	No.	HP (kW)	FLA (Ea.)	50 %	100 % <sup>(b)</sup>	HP (kW)	FLA (Ea.)
TC/TE/YC*275	380-415/50/3	1/10, 1/11	21.0/23.0	147/158	1/6, 2/9	14.1, 16.8	98, 142	7.5 (5.6) 10 (6.8)	13.6/14.1 16.0/15.5	3	0.75 (0.56)	4.4	1	2	0.75 (0.56)	1.7
TC/TE/YC*305	380-415/50/3	2/11	23.0	158	1/6, 2/10	14.1, 18.6	98, 142	7.5 (5.6) 10 (6.8)	13.6/14.1 16.0/15.5	3	0.75 (0.56)	4.4	1	2	0.75 (0.56)	1.7
TC/TE/YC*350	380-415/50/3	1/11, 1/12	23.0/27.5	158/197	1/6, 2/11	14.1, 19.2	98, 147	7.5 (5.6) 10 (6.8) 15 (10.5)	13.6/14.1 16.0/15.5 24.0/26.0	3	0.75 (0.56)	4.4	1	2	0.75 (0.56)	1.7
TC/TE/YC*400	380-415/50/3	1/11, 1/17	23.0/34.0	158/215	1/8, 2/13	14.1, 23.0	98, 158	10 (6.8) 15 (10.5)	16.0/15.5 24.0/26.0	4	0.75 (0.56)	4.4	1	2	1.0 (0.75)	2.5
TC/TE/YC*500	380-415/50/3	2/11, 1/12	23.0/27.5	158/197	1/10, 2/15	18.6, 27.5	142, 155	10 (6.8) 15 (10.5) 20 (12.8)	16.0/15.5 24.0/26.0 29.0/28.0	4	0.75 (0.56)	4.4	1	2	1.0 (0.75)	2.5

**Note:** All customer wiring and devices must be installed in accordance with local and national electrical codes.

**Note:** Allowable voltage range for the 380V unit is 342-418V, allowable voltage range for the 415V unit is 373-456.

(a) All condenser fan motors are single phase.

(b) 100% Power Exhaust is with or without Statitrac.

**Electrical Data**


---

**Table 61. Electrical service sizing data – crankcase heaters (heating mode only) – 50Hz**

Nominal Unit Size (Tons)	FLA Add	
	Unit Voltage	
	380	415
23 - 29	1	1
33 - 42	1	1

**Table 62. Electrical service sizing data – electric heat module (electric heat units only) – 50Hz**

Models: TE(D,H,F,R) 275 thru 500 Electric Heat FLA						
Nominal Unit Size (Tons)	Nominal Unit Voltage	KW Heater (380/415V)				
		23/27	34/40	45/54	56/67	68/81
23-29	380	34.5	51.1	68.9	85.5	–
	415	37.6	55.6	–	–	–
33, 42	380	–	51.1	68.9	85.5	103.4
	415	–	55.6	75.1	93.2	112.7

**Note:** All FLA in this table are based on heater operating at 380 or 415 volts as shown above.

# Dimensional Data

## Fresh Air, Power Exhaust Hoods

Figure 9. Side view showing fresh air and power exhaust hoods for downflow return

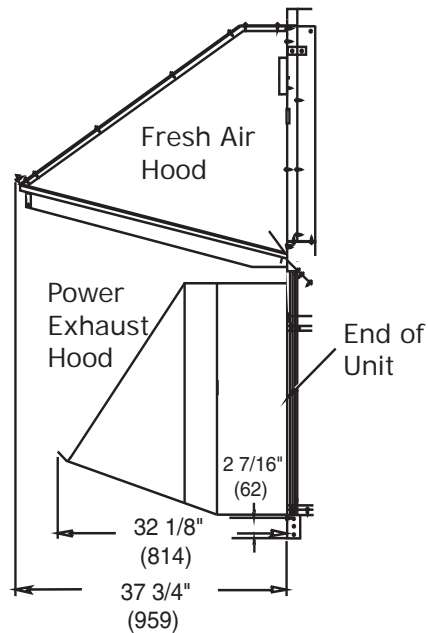
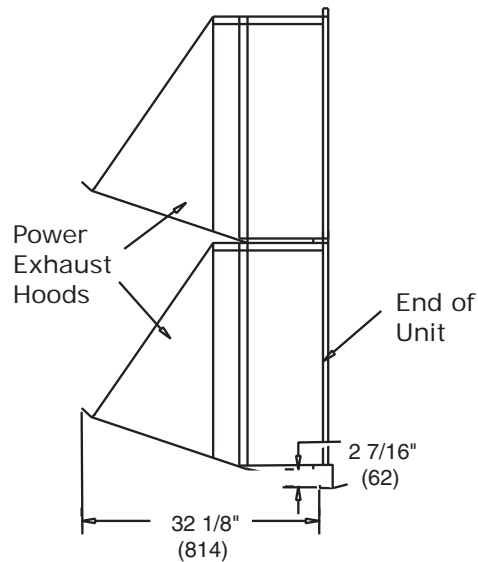
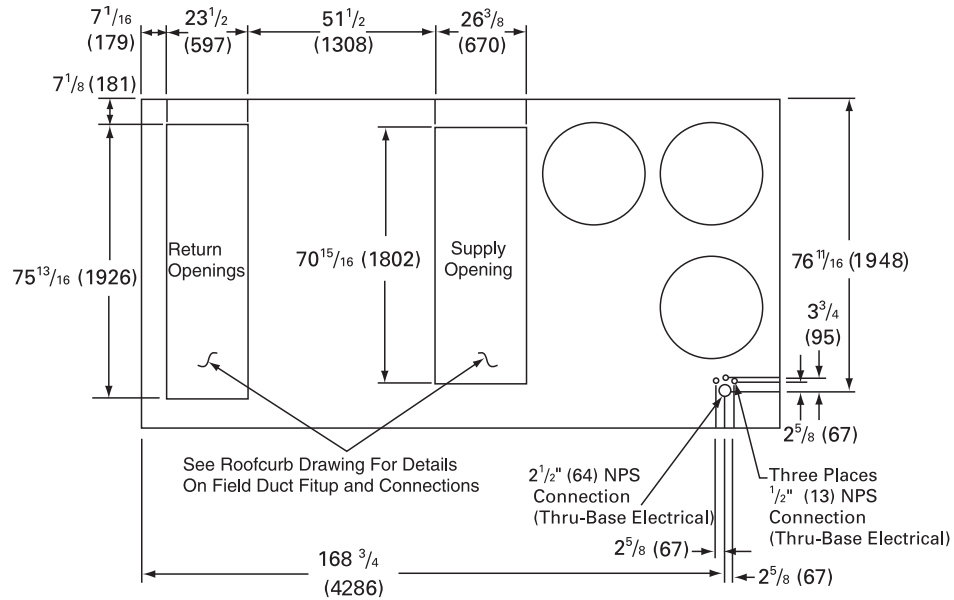


Figure 10. Side view showing power exhaust hoods for horizontal return

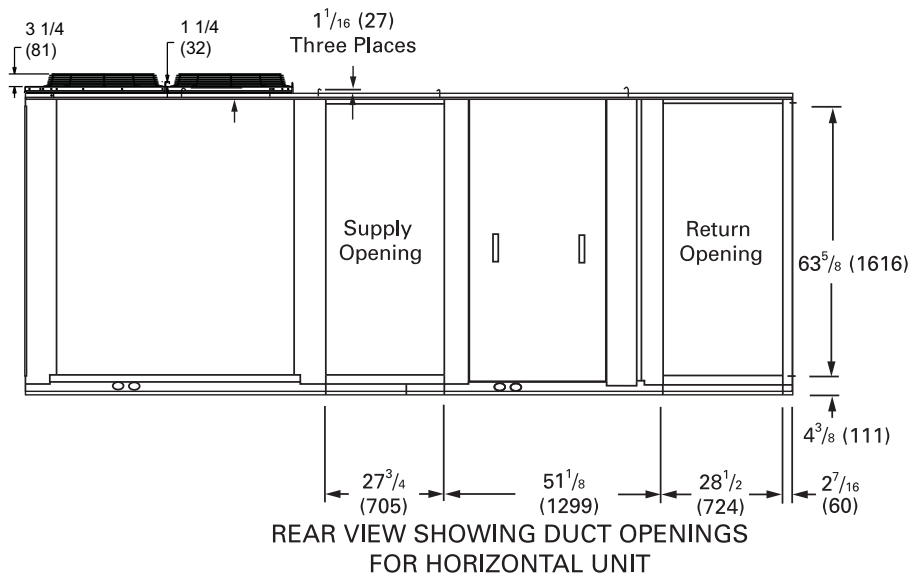


**Note:** The two horizontal power exhaust hoods and the three horizontal fresh air hoods are located side by side. The fresh air hoods (not shown) extend only  $23 \frac{15}{16}$ \" from the end of the unit.

**Figure 11. 60 Hz 27½-35, 50 Hz 23-29 Tons (TCD, TED, YCD low heat)**



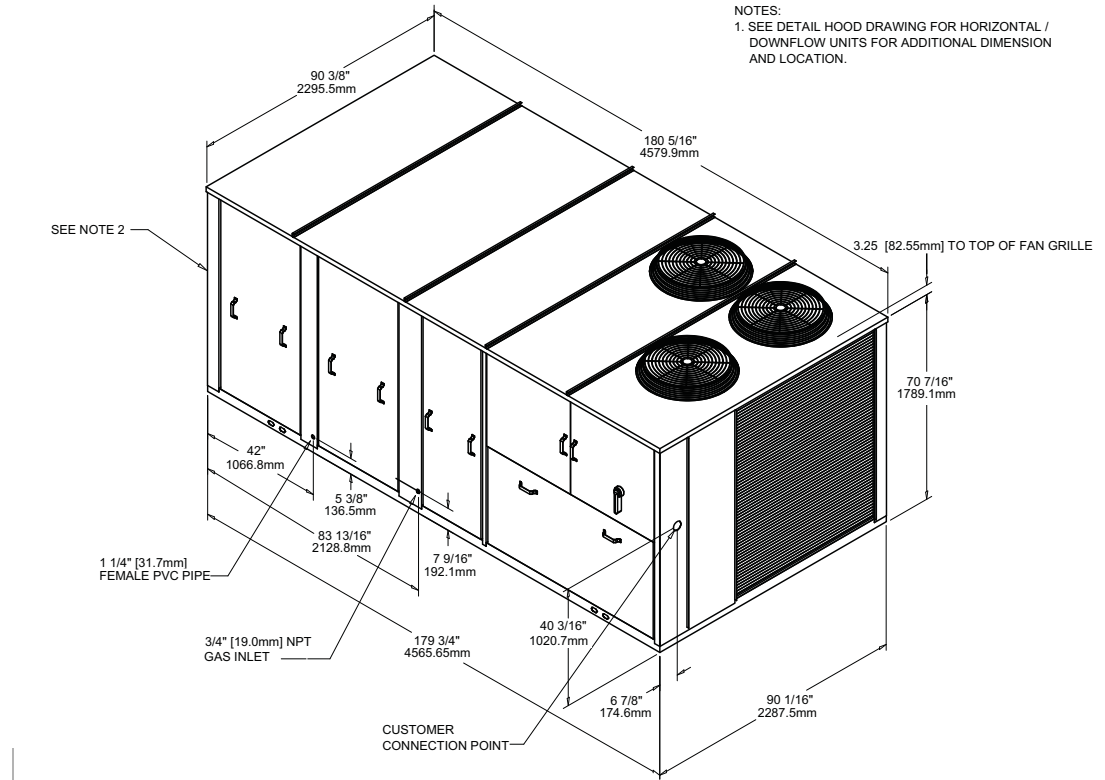
**Figure 12. Rear view showing duct openings for horizontal supply and return, 60 Hz 27½-35, 50Hz 23-29 Tons (TCH, TEH, YCH low heat)**



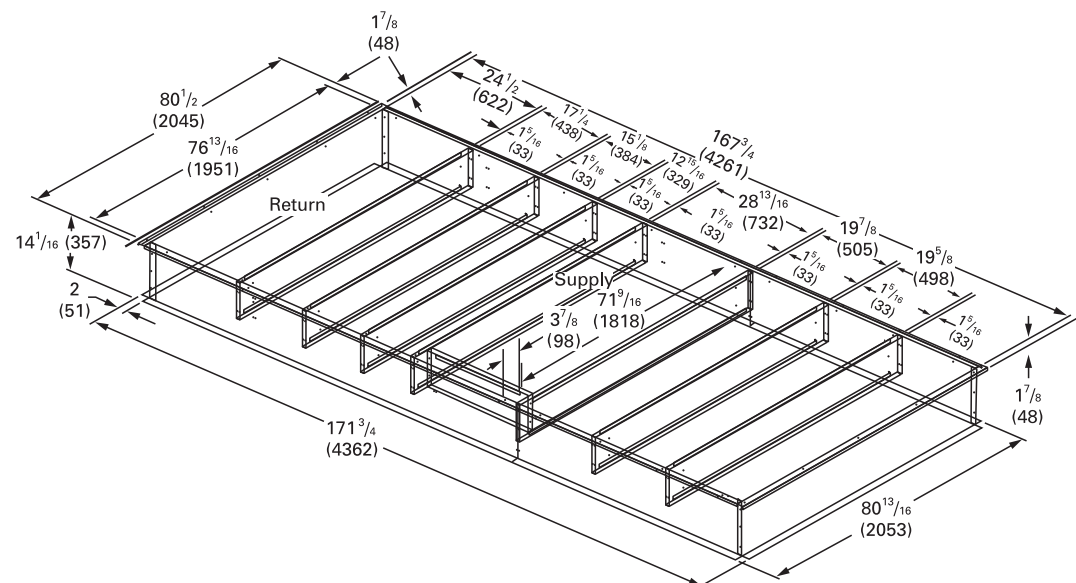
**Notes:**

- On horizontal units, the VFD is located between the supply and return ductwork, which makes access limited.
- For combination of horizontal and downflow openings (digit 3 = F or R) see [Figure 11](#) for appropriate downflow dimensions and [Figure 12](#) for appropriate horizontal dimensions.

**Figure 13. 60 Hz 27½-35, 50 Hz 23-29 tons (TC, TE, YC low heat)**



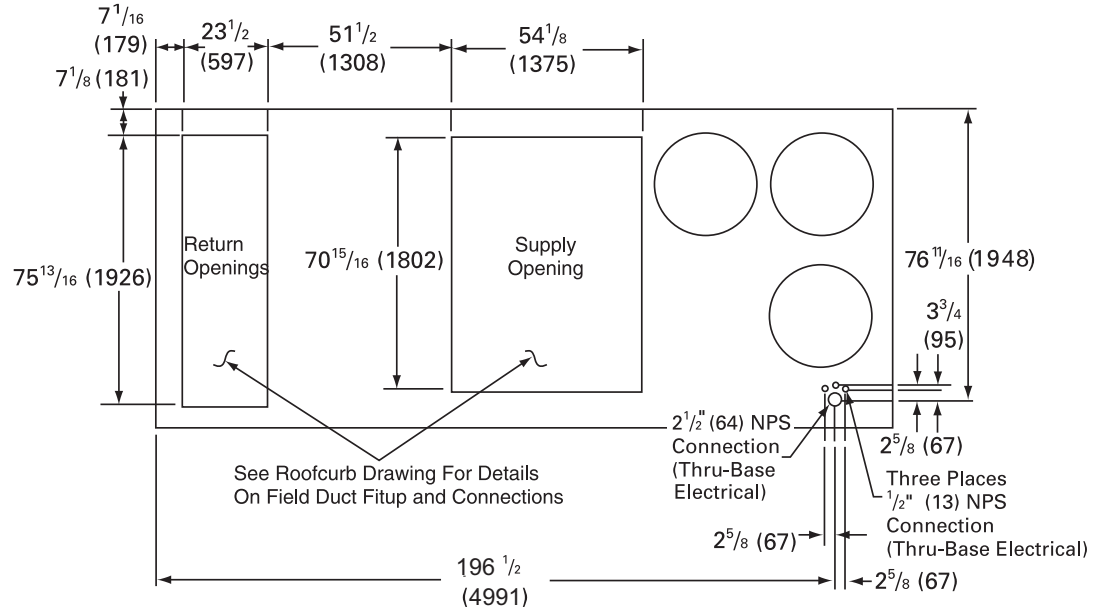
**Figure 14. Curb assembly, 60 Hz 27½-35, 50 Hz 23-29 tons (TC, TE, YC low heat)**



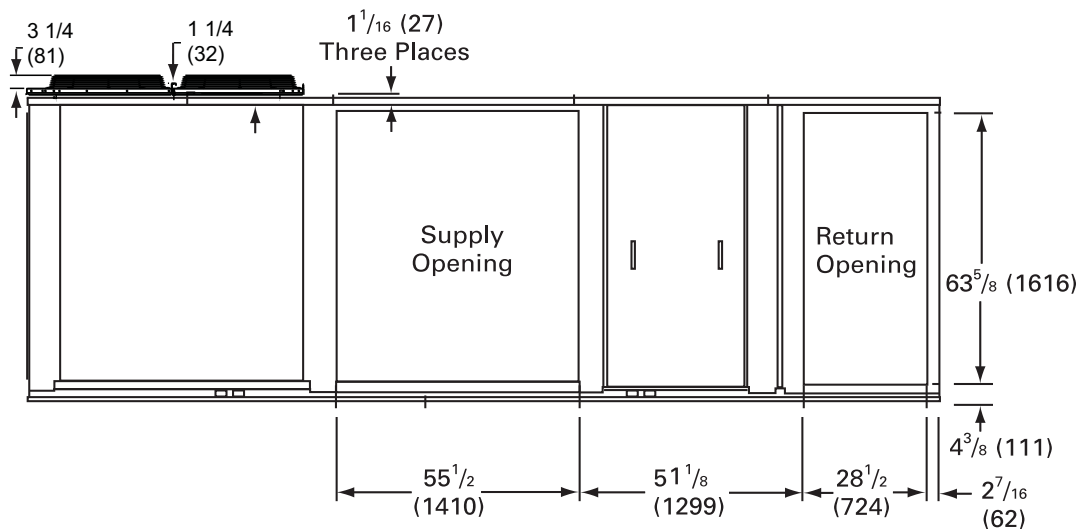
**Note:** Dimensions in ( ) are mm, 1" = 25.4 mm.

## Dimensional Data

**Figure 15. 60 Hz 27½-35, 50 Hz 23-29 tons (YCD high heat)**



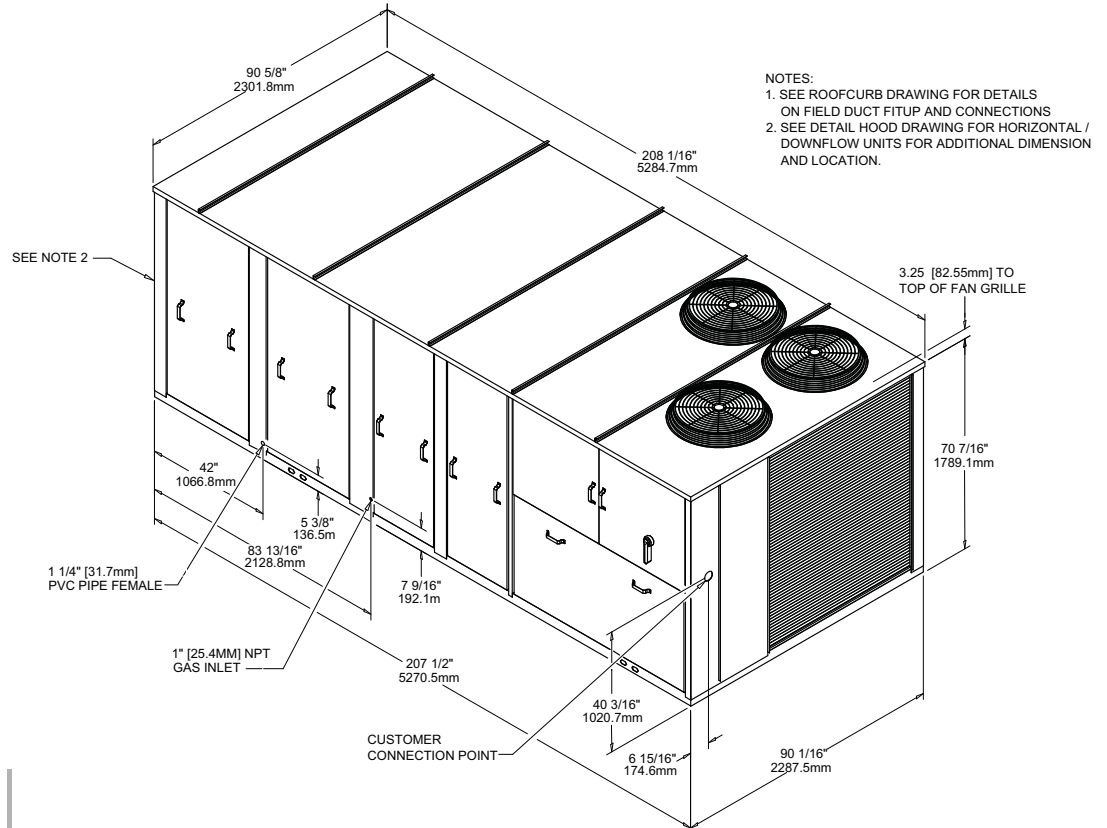
**Figure 16. Rear view showing duct openings for horizontal supply and return, 60 Hz 27½-35, 50Hz 23-29 Tons (YCH high heat)**



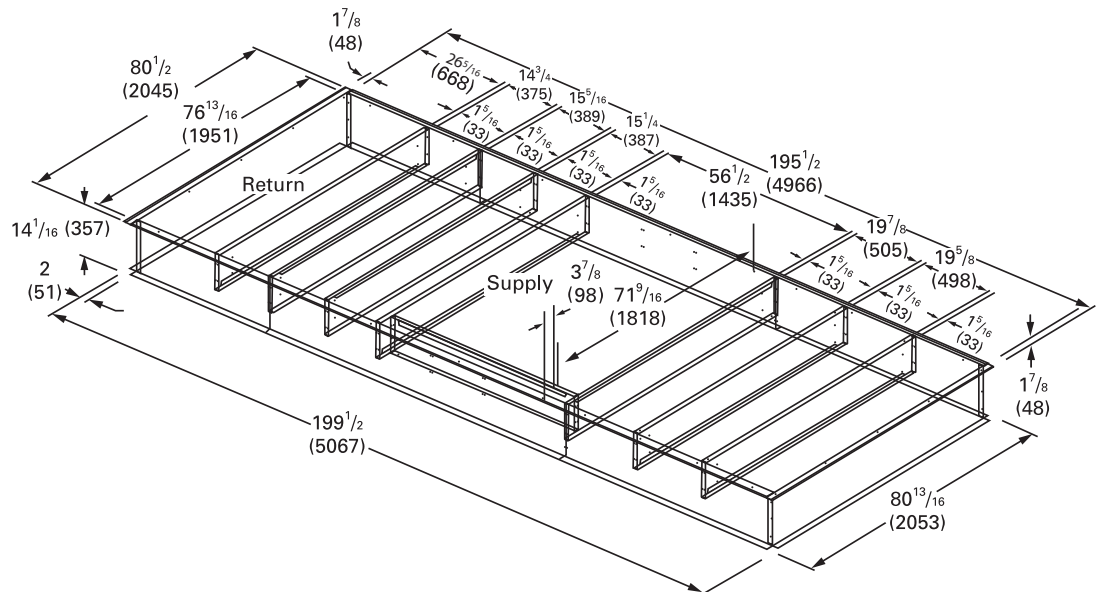
**Notes:**

- On horizontal units, the VFD is located between the supply and return ductwork, which makes access limited.
- For combination of horizontal and downflow openings (digit 3 = F or R) see [Figure 15](#) for appropriate downflow dimensions and [Figure 16](#) for appropriate horizontal dimensions.

**Figure 17. 60 Hz 27½-35, 50 Hz 23-29 tons (YC high heat)**

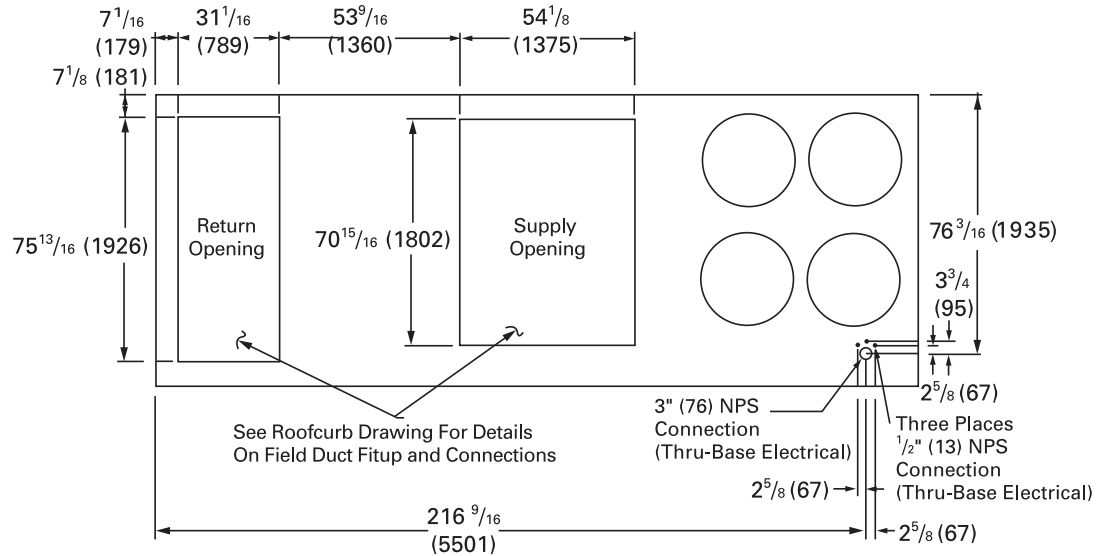


**Figure 18. Curb assembly, 60 Hz 27½-35, 50 Hz 23-29 tons (YC high heat)**

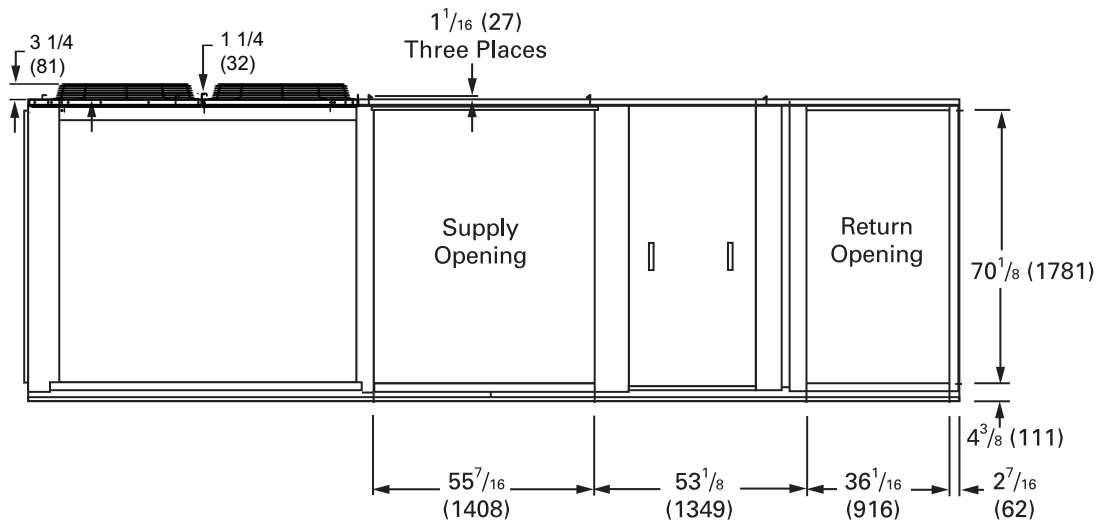


**Note:** Dimensions in ( ) are mm, 1"= 25.4 mm.

**Figure 19. 60 Hz 40-50, 50 Hz 33-42 tons (TCD, TED, YCD low and high heat)**



**Figure 20. Rear view showing duct openings for horizontal supply and return, 60 Hz 40-50, 50Hz 33-42 Tons (TCH, TEH, YCH low and high heat)**

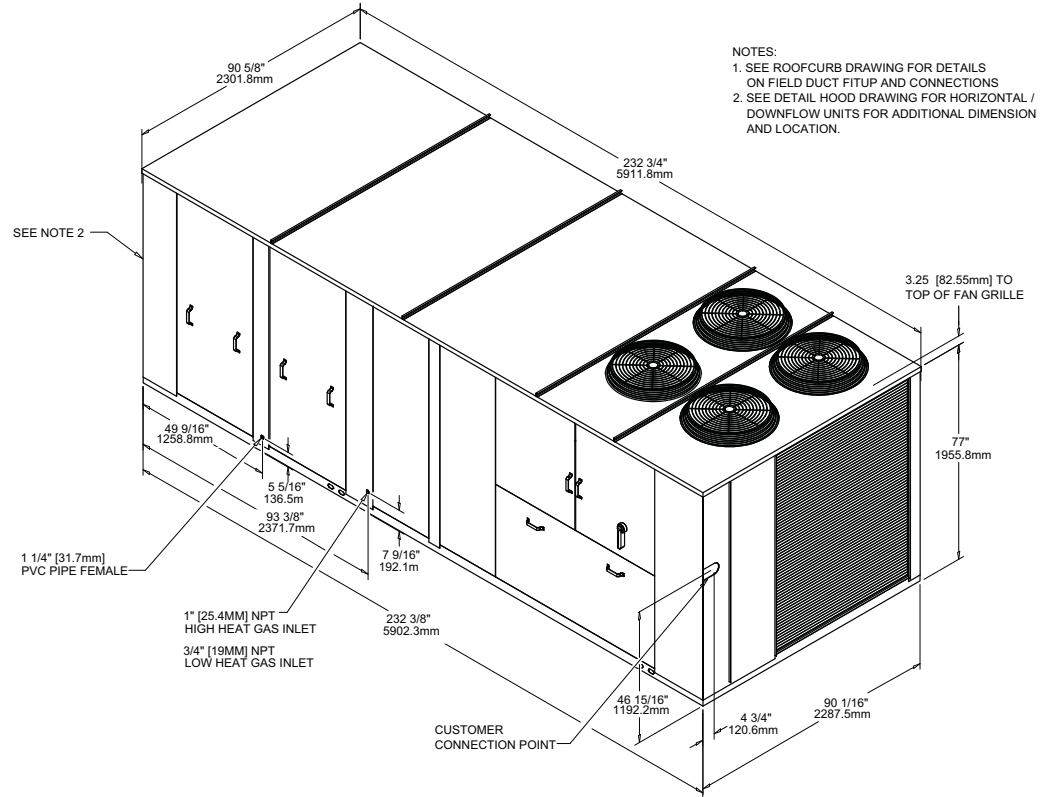


**Notes:**

- On horizontal units, the VFD is located between the supply and return ductwork, which makes access limited.
- For combination of horizontal and downflow openings (digit 3 = F or R) see [Figure 19](#) for appropriate downflow dimensions and [Figure 20](#) for appropriate horizontal dimensions.

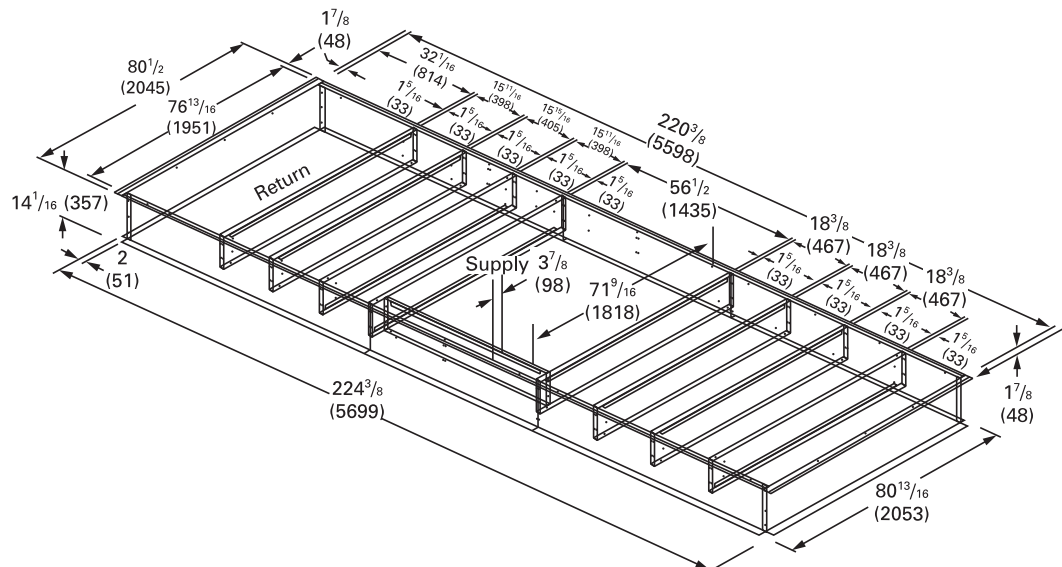


**Figure 21. 60 Hz 40-50, 50 Hz 33-42 tons (TC, TE, YC low and high heat)**



- NOTES:  
 1. SEE ROOFCURB DRAWING FOR DETAILS ON FIELD DUCT FITUP AND CONNECTIONS  
 2. SEE DETAIL HOOD DRAWING FOR HORIZONTAL / DOWNFLOW UNITS FOR ADDITIONAL DIMENSION AND LOCATION.

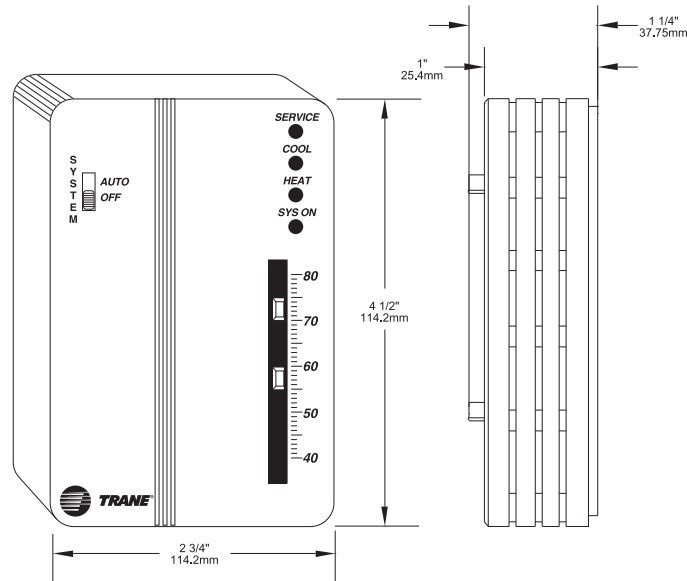
**Figure 22. Curb assembly, 60 Hz 40-50, 50 Hz 33-42 tons (TC, TE, YC low and high heat)**



**Note:** Dimensions in ( ) are mm, 1" = 25.4 mm.

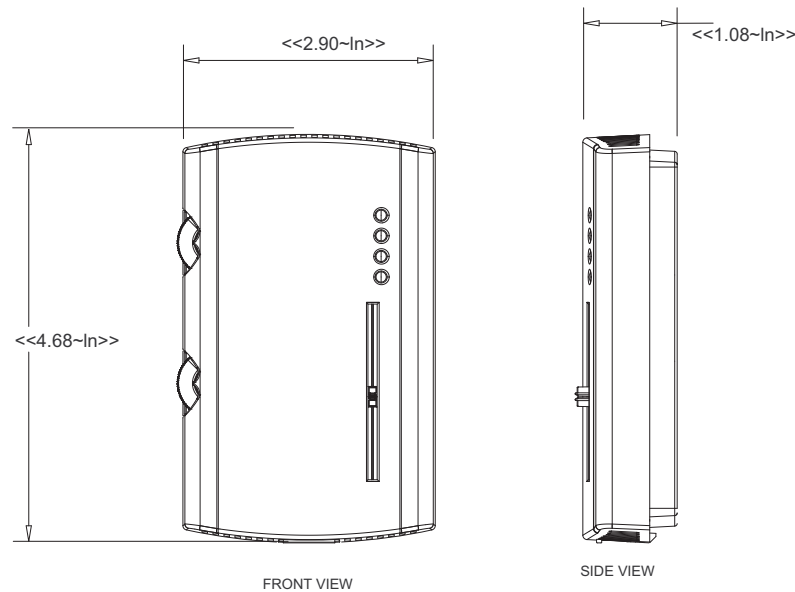
## Field Installed Sensors—Variable Air Volume VAV

Figure 23. Single setpoint sensor with system function lights (BAYSENS021\*)



## Field Installed Sensors—Constant Volume CV or Single Zone Variable Air Volume SZ VAV

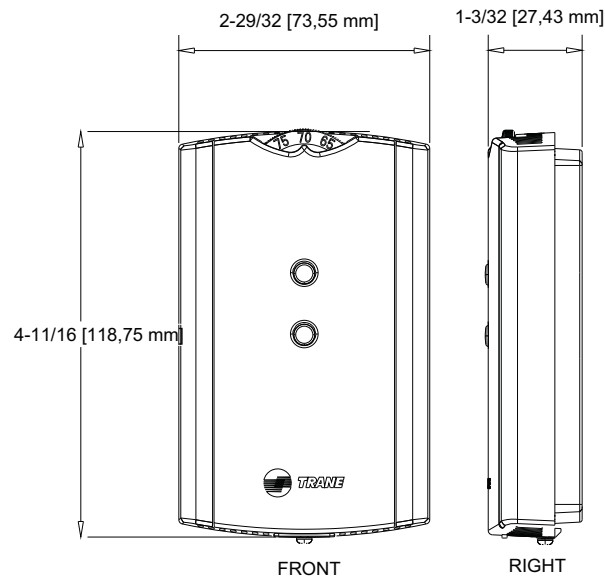
Figure 24. Dual setpoint, manual/automatic changeover sensor with system function lights (BAYSENS110\*), without LED status indicators (BAYSENS108\*), single setpoint without LED status indicators (BAYSENS106\*)



**Note:** Remote sensors are available for use with all zone sensors to provide remote sensing capabilities.

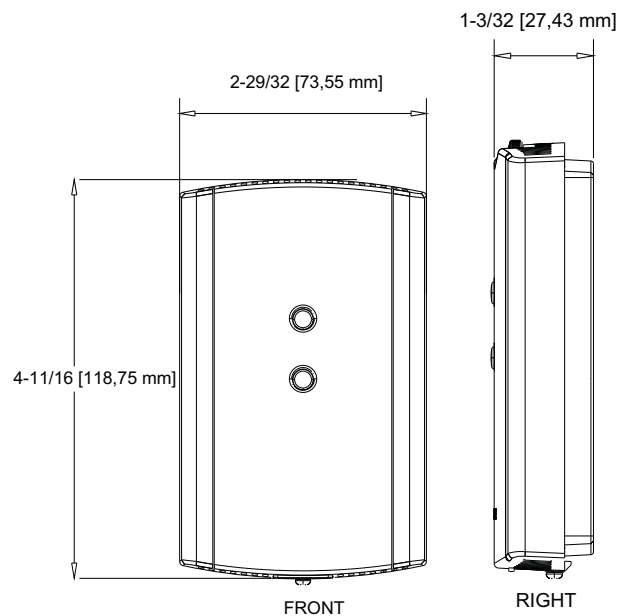
## Integrated Comfort™ System Sensors—CV, VAV, and SZ VAV

**Figure 25. Zone temperature sensor with timed override button and local setpoint adjustment (BAYSENS074)**

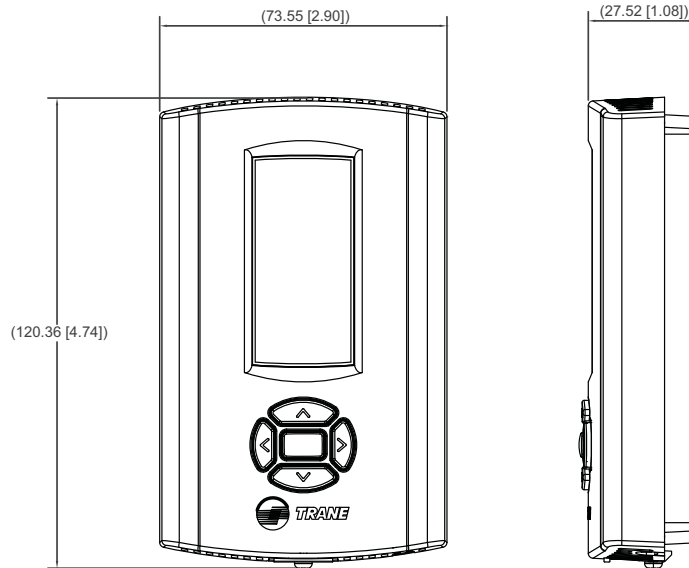


**Note:** Remote sensors are available for use with all zone sensors to provide remote sensing capabilities.

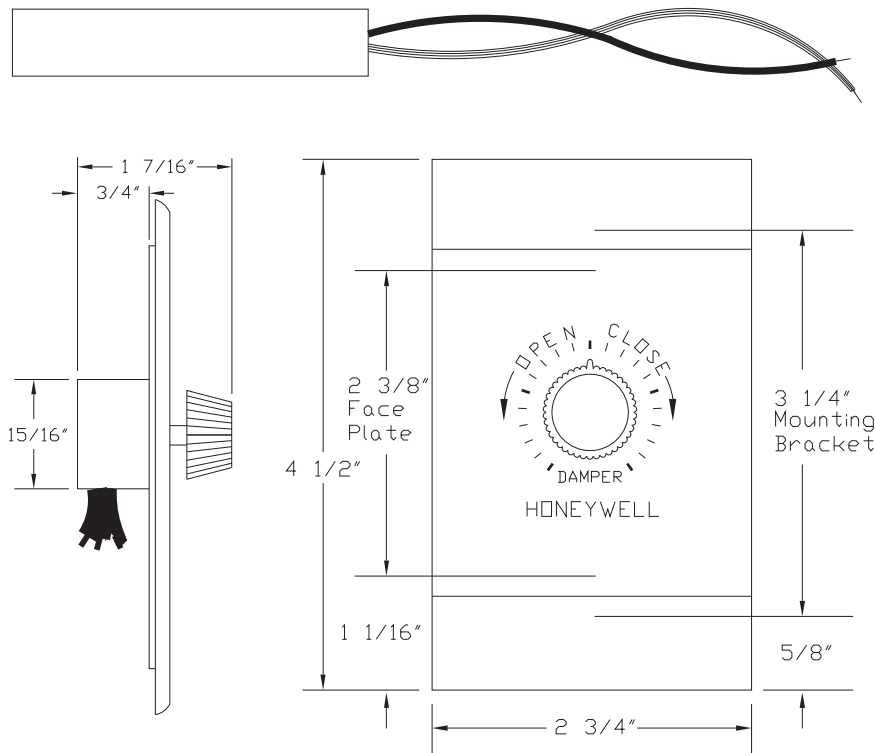
**Figure 26. Zone temperature sensor with timed override buttons (BAYSENS073\*) also available sensor only (BAYSENS077\*)**



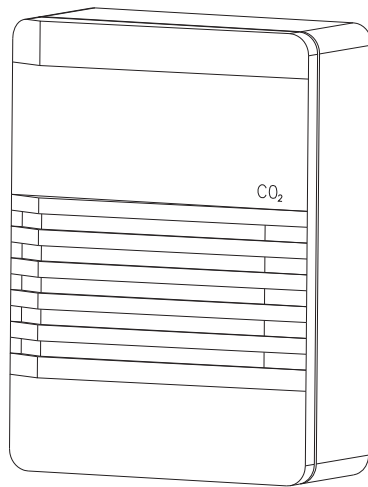
**Figure 27. Zone temperature sensor with timed override button and local setpoint adjustment (BAYSENS119)**



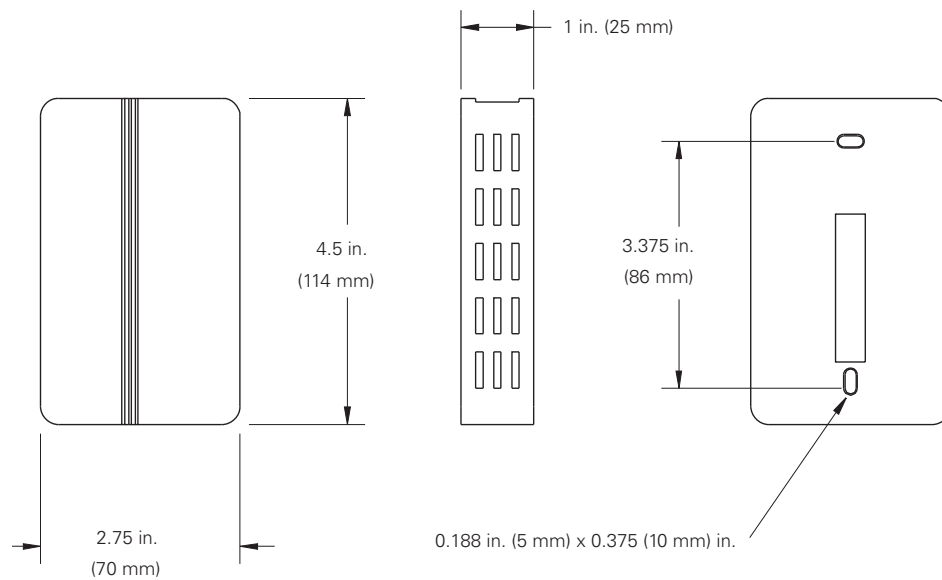
**Figure 28. Temperature sensor (BAYSENS016\*) (top) and remote minimum position potentiometer control (BAYSTAT023\*) (bottom)**



**Figure 29. Wall-mounted CO<sub>2</sub> sensor (BAYCO2K005\*), duct-mounted CO<sub>2</sub> sensor (not pictured) (BAYCO2K006\*)**



**Figure 30. Field installed humidity sensor—wall (BAYSENS036\*) or duct mount (BAYSENS037\*)**



# Weights

**Table 63. Approximate units operating weights — lbs./kg**

Unit Model (60Hz/50Hz)	Basic Unit Weights <sup>(a)</sup>			
	YC Low Heat	YC High Heat	TC	TE
330/275	3720 / 1687	4150 / 1882	3590 / 1628	3610 / 1637.5
360/305	3795 / 1721	4225 / 1916	3665 / 1662	3685 / 1671.5
420/350	3876 / 1758	4306 / 1953	3746 / 1699	3766 / 1708
480/400	4825 / 2189	4950 / 2245	4565 / 2071	4600 / 2086.5
600/500	5077 / 2303	5202 / 2360	4827 / 2189.5	4852 / 2201

(a) Basic unit weight includes minimum horsepower supply fan motor.

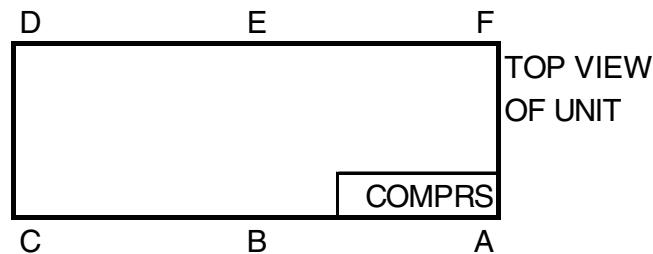
**Table 64. Point loading average weight — lbs./kg**

Unit Model (60Hz/50Hz)	A	B	C	D	E	F
330/275	852 / 386	695 / 315	754 / 342	740 / 335	602 / 273	504 / 228
360/305	878 / 398	681 / 309	750 / 340	713 / 323	577 / 262	622 / 282
420/350	841 / 381	842 / 382	669 / 303	735 / 333	582 / 264	634 / 287
480/400	835 / 378	869 / 394	950 / 431	748 / 339	769 / 349	776 / 352
600/500	882 / 400	931 / 422	954 / 433	740 / 336	844 / 382	847 / 384

**Notes:**

1. Point Loading is identified with corner A being the corner with the compressors. As you move clockwise around the unit as viewed from the top, mid-point B, corner C, corner D, mid-point E and corner F.
2. Point load calculations provided are based on the unit weight for YC high heat gas models.

**Figure 31. Point loading**



**Table 65. Approximate operating weights— optional components — lbs./kg**

Unit Model (60Hz/50Hz)	Baro. Relief	Power Exhaust	0-25% Man Damper	Econ.	Var. Freq. Drives (VFD's)		Serv Valves	Thru- the base Elec.	Non- Fused Discon. Switch	Factory GFI with Discon. Switch	Roof Curb	
					W/O	With					Lo	Hi
					Bypass							
** (D,F)330/275	110/50	165/74	50/23	260/117	85/39	115/52	18/8	6/3	30/14	85/38	310/141	330/150
** (H,R)330/275	145/65	200/90	50/23	285/128	85/39	115/52	18/8	6/3	30/14	85/38	310/141	330/150
** (D,F)360/305	110/50	165/74	50/23	260/117	85/39	115/52	18/8	6/3	30/14	85/38	310/141	330/150
** (H,R)360/305	145/65	200/90	50/23	285/128	85/39	115/52	18/8	6/3	30/14	85/38	310/141	330/150
** (D,F)420/350	110/50	165/74	50/23	260/117	85/39	115/52	18/8	6/3	30/14	85/38	310/141	330/150
** (H,R)420/350	145/65	200/90	50/23	285/128	85/39	115/52	18/8	6/3	30/14	85/38	310/141	330/150
** (D,F)480/400	110/50	165/74	50/23	290/131	115/52	150/68	18/8	6/3	30/14	85/38	365/169	365/169
** (H,R)480/400	145/65	200/90	50/23	300/135	115/52	150/68	18/8	6/3	30/14	85/38	365/169	365/169
** (D,F)600/500	110/50	165/74	50/23	290/131	115/52	150/68	18/8	6/3	30/14	85/38	365/169	365/169
** (H,R)600/500	145/65	200/90	50/23	300/135	115/52	150/68	18/8	6/3	30/14	85/38	365/169	365/169
Unit Model (60Hz/50Hz)	HGRH Coil	Condenser Hail Guards	Ultra Low Leak Econ	Ultra Low Leak 50% Exhaust	Ultra Low Leak 100% Exhaust	High Efficiency						
** (D,F)330/275	107/49	105/48	112/51	34 / 15	74 / 34	326/148						
** (H,R)330/275	107/49	105/48	78/35	34 / 15	77 / 35	326/148						
** (D,F)360/305	107/49	105/48	112/51	34 / 15	74 / 34	255/116						
** (H,R)360/305	107/49	105/48	78 /35	34 / 15	77 / 35	255/116						
** (D,F)420/350	107/49	105/48	112/51	34 / 15	74 / 34	173/78						
** (H,R)420/350	107/49	105/48	78/35	34 / 15	77 / 35	173/78						
** (D,F)480/400	112/51	130/59	114/52	34 / 15	74 / 34	241/109						
** (H,R)480/400	112/51	130/59	100/45	34 / 15	84 / 38	241/109						
** (D,F)600/500	112/51	130/59	114/52	34 / 15	74 / 34	-25/-11						
** (H,R)600/500	112/51	130/59	100/45	34 / 15	84 / 38	-25/-11						

**Note:** Basic unit weight includes minimum horsepower supply fan motor.

**Table 66. Minimum operating clearances for unit installation**

	Econo/Exhaust End	Condenser Coil <sup>(a)</sup> End/Side	Service Side Access
Single Unit <sup>(b)</sup>	6 Feet (1.82 m)	8 Feet/8 Feet (2.43/2.43 m)	4 Feet (1.21 m)
Multiple Unit <sup>(b)(c)</sup>	12 Feet (3.65 m)	16 Feet/16 Feet (4.87/4.87 m)	8 Feet (2.43 m)

(a) Condenser coil is located at the end and side of the unit.

(b) Horizontal, downflow, and mixed airflow configuration units, all sizes.

(c) Clearances on multiple unit installations are distances between units.



# Mechanical Specifications

## General

The units shall be dedicated downflow, horizontal, or mixed airflow configuration. The operating range shall be between 115°F and 0°F in cooling as standard from the factory for all units. Cooling performance shall be rated in accordance with ARI testing procedures. All units shall be factory assembled, internally wired, fully charged with R-410A refrigerant and 100% run tested to check cooling operation, fan and blower rotation and control sequence before leaving the factory. Wiring internal to the unit shall be numbered for simplified identification. Units shall be UL listed to U.S. and Canadian safety standards.

## Casing

Unit casing shall be constructed of zinc coated, heavy gauge, galvanized steel phosphatized, and finished with a pre-applied baked polyurethane enamel. All components shall be mounted in a weather resistant steel cabinet with a painted exterior. Cabinet surface shall be tested 672 hours in salt spray in compliance with ASTM B117. Fully gasketed removable access panels. Structural members shall be heavy gauge with access doors and removable panels of heavy gauge. Provide 1/2 inch thick foil faced fiberglass insulation on all exterior panels and roof in contact with the return and conditioned air stream. Where top cover seams exist, they shall be double hemmed and gasket sealed to prevent water leakage. Cabinet construction shall allow for all maintenance on one side of the unit. Service panels shall have handles and shall be removable while providing a water and air tight seal. Control box access shall be hinged. The indoor air section shall be completely insulated with fire resistant, permanent, odorless, foil faced glass fiber material. The base of the unit shall have provisions for crane lifting.

## Filters

Two inch, MERV 4, throwaway filters shall be standard on all size units. MERV 8 two inch "high efficiency"; MERV 8 four inch "high efficiency" and MERV 14 four inch "high efficiency" filters shall be optional.

## Compressors

The 3-D Scroll shall include a direct-drive, 3600 rpm, suction gas cooled hermetic motor. Dependent on the compressor model, motor protection shall be provided by either a patented motor cap and integral line break motor protector or an external 24 Vac module which provides protection against incorrect phase sequence, excess motor temperatures, over current protection, and phase loss. Trane 3-D compressor shall include centrifugal oil pump, scroll tips seals, internal heat shield that lowers the heat transfer from discharge and suction gas, oil level sight glass and oil charge valve. Some compressor models shall also provide a dip tube that allows for oil draining, in addition to a low leakage internal discharge check valve to help prevent refrigerant migration. Each compressor shall have a crankcase heater installed, properly sized to minimize the amount of liquid refrigerant present in the oil sump during off cycles.

## High Efficiency Unit (eStage)

The High Efficiency, eStage option shall provide five stages of mechanical cooling with the ability to be at or below 25% compressor displacement at stage one.

## Refrigerant Circuits

Each refrigerant circuit shall have independent thermostatic expansion devices, service pressure ports and refrigerant line filter driers factory-installed as standard. An area shall be provided for replacement suction line driers.



## Evaporator and Condenser Coils

Condenser coils shall have all Aluminum Microchannel coils. Evaporator coils shall be internally finned Copper tubes mechanically bonded to high performance Aluminum plate fins. All coils shall be leak tested at the factory to ensure pressure integrity. The evaporator coil is pressure tested to 450 psig and the condenser coil at 650 psig. All dual circuit evaporator coils shall be of intermingled configuration. Sloped condensate drain pans are standard.

## Outdoor Fans

The outdoor fan shall be direct-drive, statically and dynamically balanced, draw through in the vertical discharge position. The fan motor(s) shall be permanently lubricated and have built-in thermal overload protection in a weather tight casing.

## Indoor Fan

Units shall have belt driven, FC, centrifugal fans with fixed motor sheaves. Complete fan assemblies shall be statically and dynamically balanced. Fan shaft shall be mounted on grease lubricated ball bearings. All motors shall be circuit breaker protected. All 50 Hz indoor fan motors meet the U.S. Energy Policy Act of 1992 (EPACT). All 60 Hz indoor fan motors meet the Energy Independence & Security Act of 2007 (EISA).

## Electric Heaters

Electric heat shall be available for factory installation within basic unit. Electric heater elements shall be constructed of heavy-duty nickel chromium elements internally delta connected for 240 volt and wye connected for 480 and 600 volt. Staging shall be achieved through the rooftop refrigeration module (RTRM). Each heater package shall have automatically reset high limit control operating through heating element contactors. All heaters shall be individually fused from factory, where required, and meet all NEC and CEC requirements. Power assemblies shall provide single-point connection. Electric heat shall be cULus listed.

## Gas Heating Section

The heating section shall have a drum and tube heat exchanger(s) design with primary and secondary surfaces of corrosion resistant aluminized steel or optional stainless steel (all modulating gas heat units shall have stainless steel).

A forced combustion blower shall supply premixed fuel to a single burner ignited by a pilotless hot surface ignition system. In order to provide reliable operation, a regulated gas valve shall be used that requires blower operation to initiate gas flow. On an initial call for heat, the combustion blower shall purge the heat exchanger(s) 45 seconds before ignition. After three unsuccessful ignition attempts, the entire heating system shall be locked out until manually reset at the thermostat.

Two stage gas heat units shall be suitable for use with natural gas or propane (field installed kit). Modulating gas heat units shall be suitable for use with natural gas only. Both two stage and modulating gas heat units comply with California requirements for low NOx emissions.

Modulating gas turn down ratio on high fire units is accomplished by allowing the furnaces to act independently of one another. The modulating bank is activated first and is allowed to modulate itself to meet the heating needs. If the modulating bank is unable to meet the need at high fire, the second bank is turned on and then the first bank again modulates to the appropriate level. This system creates a nearly seamless range of capacity from low fire on the modulating bank to high fire of both furnaces together.

## Controls

Unit shall be completely factory wired with necessary controls and terminal block for power wiring. Units shall provide an external location for mounting fused disconnect device. ReliaTel controls shall be provided for all 24 volt control functions. The resident control algorithms shall make all



## Mechanical Specifications

---

heating, cooling and/or ventilating decisions in response to electronic signals from sensors measuring indoor and outdoor temperatures. The control algorithm maintains accurate temperature control, minimizes drift from set point and provides better building comfort. ReliaTel controls shall provide anti-short cycle timing and time delay between compressors to provide a higher level of machine protection

## Control Options

### Variable Frequency Drives (VFDs)

VFDs shall be factory installed and tested to provide supply fan motor speed modulation. If the unit is configured for traditional VAV control, the VFD shall receive a 0-10 Vdc signal from the unit controls based upon supply static pressure and shall cause the drive to accelerate or decelerate as required to maintain the supply static pressure setpoint. The VFD shall receive a 0-10 Vdc signal from the unit controls based on zone demand if configured for Single Zone VAV control and shall cause the drive to accelerate or decelerate as required to maintain the load of the zone. When subjected to high ambient return conditions the VFD shall reduce its output frequency to maintain operation. Bypass control to provide full nominal air flow in the event of drive failure shall be optional.

### Ventilation Override

Ventilation Override shall allow a binary input from the fire/life safety panel to cause the unit to override standard operation and assume one of three factory preset ventilation sequences, exhaust, pressurization or purge. The three sequences shall be selectable based upon a binary select input.

### Trane Communication Interface (TCI)

Shall be provided to interface with the Trane Integrated Comfort™ System and shall be available field or factory-installed. The TCI shall allow control and monitoring of the rooftop unit via a two-wire communication link.

### LonTalk Communication Interface (LCI-R)

The field or factory-installed ReliaTel® LonTalk Communication Interface (LCI-R) will be provided to interface with the Trane Integrated Comfort System or LonTalk capable third party building management networks. The LCI-R will allow control and monitoring of the rooftop unit via a two-wire communication link.

### BACnet Communication Interface (BCI-R)

The BACnet Communication Interface for ReliaTel (BCI-R) supports Trane™ ReliaTel rooftop units that function as part of a Trane SC system controller network. It allows ReliaTel equipment to communicate with a building automation system (BAS) by using the BACnet protocol over an RS-485 MS/TP communications link.

### Air-Fi™ Wireless Comm Interface (WCI) - Field Installed

The Trane Air-Fi Wireless Comm interface provides a wireless communication link between the Tracer SC, Tracer evo Unit Controllers and BACnet Communication Interface modules. This option is field installed only.

### Human Interface

The Human Interface shall have a 5 inch color touchscreen display that conforms to FCC Part 15 Class B with an Ingress Protection Rating of IP24. The display text shall be readable by a person with 20/20 vision at a distance of 3 feet and 60° angle at lighting levels ranging from 100 lux - 25,000

lux. Also, the display shall operate at temperatures of -40°C to 70°C. Firmware and unit configurations shall be able to be restored via a USB storage device.

## Outside Air

### Manual Outside Air

A manually controllable outside air damper shall be adjustable for up to 25 percent outside air. Manual damper is set at desired position at unit start up.

### Economizer

Economizer shall be factory installed. The assembly includes: fully modulating 0-100 percent motor and dampers, minimum position setting(s), preset linkage, wiring harness, and fixed dry bulb control. Solid state enthalpy and differential enthalpy control shall be a factory or field installed option.

### Ultra Low Leak Economizer with Fault Detection and Diagnostic (FDD)

The return air and fresh air dampers shall be provided with airfoil blades and independent direct drive actuators. Dampers shall have a leakage rate of 3 CFM/sq-ft at 1.0 in WC pressure differential (AMCA Class 1A). Dampers shall have a functional life of 60,000 opening & closing cycles.

**Note:** Based on testing completed in accordance with AMCA Standard 500D.

Fault Detection and Diagnostic (FDD) control shall also be provided with Ultra Low Leak Economizers. FDD control shall monitor the commanded position of the economizer compared to the feedback position of the damper. If the damper position is outside +/- 10% of the commanded position, a diagnostic shall be generated.

### Outside Air Measurement (Traq™)

A factory mounted airflow measurement station (Traq™) shall be provided in the outside air opening to measure airflow. The airflow measurement station shall measure from 40 cfm/ton maximum airflow. The airflow measurement station shall adjust for temperature variations. Measurement accuracy shall meet requirements of LEED IE Q Credit 1 as defined by ASHRAE 62.1-2007.

## Exhaust Air

### 100% Power Exhaust Fan

Power exhaust shall be available on all units and shall be factory installed. It shall assist the barometric relief damper in maintaining building pressurization.

### 50% Power Exhaust Fan

Power exhaust shall be available on all units and shall be factory installed. It shall assist the barometric relief damper in maintaining building pressurization.

### 100% Modulating Exhaust Fan with Statitrac™ Control Option

A differential pressure control system (Statitrac™), shall use a differential pressure transducer to compare indoor building pressure to outdoor ambient atmospheric pressure and shall turn the exhaust fans on and off and modulate the barometric exhaust dampers to control the building pressure to within the adjustable, specified dead band that shall be adjustable at the RTVM board.



## Mechanical Specifications

---

### 100% Fresh Air Tracking Power Exhaust

Modulating power exhaust shall be available on all units and shall be factory installed. It shall assist with maintaining building pressurization by exhausting a proportional amount of the entering fresh air.

### 50% Fresh Air Tracking Power Exhaust

Modulating power exhaust shall be available on the on all units and shall be factory installed. It shall assist with maintaining building pressurization by exhausting a proportional amount of the entering fresh air.

### Barometric Relief

The barometric relief damper shall be optional with the economizer. Option shall provide a pressure operated damper for the purpose of space pressure equalization and be gravity closing to prohibit entrance of outside air during the equipment "off" cycle.

### Ultra Low Leak Exhaust

The exhaust damper shall be provided with airfoil blades and independent direct drive actuator. Damper shall have a leakage rate of 3 CFM/sq-ft at 1.0 in WC pressure differential (AMCA Class 1A). Damper shall have a functional life of 60,000 opening & closing cycles.

**Note:** Based on testing completed in accordance with AMCA Standard 500D.

## Unit Options

### Clogged Filter Indication

This optional factory installed differential pressure switch allows dirty filter indication at the zone sensor with service LED. When closed, the dirty filter switch will light the service LED on the zone sensor and allow the unit to continue normal operation.

### Comparative Enthalpy Kit

Field installed enthalpy kit shall provide inputs for economizer control based upon comparison of the enthalpies of the return and outdoor air streams. Also available factory installed.

### Condenser Coil Guards

Factory installed condenser vinyl coated wire mesh coil guards shall be available to provide full area protection against debris and vandalism.

### Corrosion Protected Condenser Coil

All Aluminum Microchannel condenser coil protection shall consist of a corrosion resistant coating that shall withstand ASTM B117 Salt Spray test for 6000 hours and ASTM G85 A2 Cyclic Acidified Salt Fog test for 2400 hours. This coating shall be added after coil construction covering all tubes, headers and fin edges, therefore providing optimal protection in more corrosive environments.

### Discharge Air Sensing

Provides true discharge air sensing in heating and cooling models. This sensor is a status indicator readable through Tracer, Tracker, or LCI-R. Discharge air sensing is standard with Variable Air Volume (VAV) units, Single Zone Variable Air Volume units, and is optional with Constant Volume (CV) units.

### **GFI Convenience Outlet (Factory Powered)**

A 15A, 115V Ground Fault Interrupter convenience outlet shall be factory installed. It shall be wired and powered from a factory mounted transformer. Unit mounted non-fused disconnect with external handle shall be furnished with factory powered outlet.

### **GFI Convenience Outlet (Field Powered)**

A 15A, 115V Ground Fault Interrupter convenience outlet shall be factory installed and shall be powered by customer provided 115V circuit.

### **Unit Interrupt Rating (Short Circuit Current Rating-SCCR)**

An optional 65,000 Amp rating (480V) and 25,000 Amp rating (600V) shall be applied to the unit enclosure using a non-fused circuit breaker for disconnect switch purposes. Fan motors, compressors, and electric heat circuits shall be provided with series rated circuit breakers that will provide the unit rated level of protection. The unit shall be marked with approved cULus markings and will adhere to cULus regulations.

### **High Temperature Thermostats**

Field installed, manually resettable high temperature thermostats shall provide input to the unit controls to shut down the system if the temperature sensed at the return is 135°F or if the discharge temperature is 240°F.

### **Hinged Service Access**

Filter access panel and supply fan access panel shall be hinged for ease of unit service.

### **Hot Gas Reheat**

A reheat condenser coil shall be factory installed downstream of the unit evaporator coil. Modulating valves shall control the flow of refrigerant between the indoor reheat and outdoor condensers in response to the unit discharge air temperature in order to dehumidify the space.

### **LP Conversion Kit**

Field installed conversion kit shall provide orifice(s) for simplified conversion to liquefied propane gas. No change of gas valve shall be required.

### **Modulating Gas Heat**

Modulating Gas Heaters shall be made from grades of stainless steel suitable for condensing situations. The heater shall have a turn down ratio of 2.5 to 1 for low heat and 5 to 1 for high heat.

### **Motor Shaft Grounding Ring**

Motors with internal Shaft grounding rings can be used with VFDs to provide a conductive discharge path away from the motor bearings to ground.

### **Non-Fused Disconnect Switch**

A factory installed non-fused disconnect switch with external handle shall be provided and shall satisfy NEC requirements for a service disconnect. The non-fused disconnect shall be mounted inside the unit control box.

### **Phase Monitor**

Standard on all Voyager Commercial units. Protects 3-phase equipment from phase loss, phase reversal, and phase unbalance. Any fault condition shall send the unit into an emergency stop condition that shall not require field adjustments for resets. cULus approved.



## Mechanical Specifications

---

### Reference Enthalpy Kit

Field installed enthalpy kit shall provide inputs for economizer control based upon comparison of the outside air stream to a definable enthalpy reference point. May also be factory installed.

### Remote Potentiometer

A remote potentiometer shall be available to remotely adjust the unit economizer minimum position.

### Roof Curb

The roof curb shall be designed to mate with the unit and provide support and a water tight installation when installed properly. The roof curb design shall allow field-fabricated rectangular supply/return ductwork to be connected directly to the curb when used with downflow units. Curb design shall comply with NRCA requirements. Curb shall ship knocked down for field assembly and include wood nailer strips.

### Service Valves

Service valves shall be provided factory installed and include suction, liquid, and discharge 3-way shutoff valves.

### Single Zone Variable Air Volume

Single Zone VAV option shall be provided with all necessary controls to operate a rooftop unit based on maintaining two temperature setpoints: discharge air and zone. Option shall include factory-installed variable frequency drive (VFD) to provide supply fan motor speed modulation. During One Zone VAV cooling, the unit shall maintain zone cooling setpoint by modulating the supply fan speed more or less to meet zone load demand; and the unit will maintain discharge temperature to the discharge cooling setpoint by modulating economizer if available and staging dx cooling.

### Stainless Steel Drain Pans

Sloped stainless steel evaporator coil drain pans shall be durable, long-lasting and highly corrosion resistant.

### Condensate Overflow Switch

This option shall shut the unit down in the event that a clogged condensate drain line prevents proper condensate removal from the unit.

### Stainless Steel Heat Exchanger

Stainless steel heat exchangers shall be durable, long-lasting and highly corrosion resistant.

### Through-The-Base Electrical Provision

An electrical service entrance shall be provided which allows access to route all high and low voltage electrical wiring inside the curb, through the bottom of the outdoor section of the unit and into the control box area.

### Tool-Less Condenser Hail Guards

Tool-less, hail-protection-quality coil guards shall be available for condenser coil protection.

### Zone Sensors

Shall be provided to interface with the ReliaTel unit controls and shall be available in either manual, automatic programmable with night setback, with system malfunction lights or remote sensor options.

### **BAYCO2K005\***

Wall-mounted CO<sub>2</sub> sensor has the ability to monitor space occupancy levels within the building by measuring the parts per million of CO<sub>2</sub> (Carbon Dioxide) in the air. As the CO<sub>2</sub> levels increase, the outside air damper modulates to meet the CO<sub>2</sub> space ventilation requirements.

### **BAYCO2K006\***

Duct-mounted CO<sub>2</sub> sensor has the ability to monitor space occupancy levels within the building by measuring the parts per million of CO<sub>2</sub> (Carbon Dioxide) in the air. As the CO<sub>2</sub> levels increase, the outside air damper modulates to meet the CO<sub>2</sub> space ventilation requirements.

### **BAYICSI004\***

Field-installed Trane Communication Interface (TCI).

### **BAYLTCI003\***

Field-installed LonTalk Communication Interface (LCI-R) for Constant Volume (CV) and Single Zone VAV (SZ VAV) units.

### **BAYLTCI004\***

Field-installed LonTalk Communication Interface (LCI-R) for Variable Air Volume (VAV) units.

### **BAYBCIR001\***

Field-installed BACnet Communication Interface (BCI-R).

### **BAYSENS016\***

Temperature Sensor is a bullet or pencil type sensor that could be used for temperature input such as return air duct temperature.

### **BAYSENS021\***

Zone Sensor with supply air single temperature setpoint and AUTO/OFF system switch. Status indication LED lights, System ON, Heat, Cool, and Service are provided. Sensors are available to be used with VAV units.

### **BAYSENS036/37\***

This wall or duct-mounted humidity sensor shall be used to control activation of the hot gas reheat dehumidification option. The humidity sensor can be set for humidity levels between 40% and 60% relative humidity.

### **BAYSENS073\***

Zone temperature sensor with timed override buttons used with Tracer™ Integrated Comfort system.

### **BAYSENS074\***

Zone temperature sensor with local temperature adjustment control and timed override buttons used with Tracer Integrated Comfort system. May also be used for Morning Warm-up setpoint and sensor.

### **BAYSENS077\***

Remote Sensor can be used for remote zone temperature sensing capabilities when zone sensors are used as remote panels or as a morning warm-up sensor for use with VAV units or as a zone sensor with Tracer Integrated Comfort system.

### **BAYSENS106\***

Zone Sensor has one temperature setpoint lever, heat, off or cool system switch, fan auto or fan on switch. Manual changeover. These sensors are for CV or SZ VAV units only.



## Mechanical Specifications

---

### **BAYSENS108\***

Zone Sensor has two temperature setpoint levers, heat, auto, off, or cool system switch, fan auto or fan on switch. Auto changeover. These sensors are used with CV or SZ VAV units.

### **BAYSENS110\***

Zone Sensor has two temperature set point levers, heat, auto, off, or cool system switch, fan auto or fan on switch. Status indication LED lights, System on, Heat, Cool, and Service are provided. These sensors are used with CV and SZ VAV units.

### **BAYSENS119\***

Electronic programmable sensors with auto or manual changeover with seven day programming. Keyboard selection of heat, cool, auto fan or on. All programmable sensors have System on, Heat, Cool, Service LED/LCD indicators as standard. Night setback sensors have one occupied, one unoccupied, and one override programs per day. Sensors are available for CV, VAV and SZ VAV temperature control.

### **BAYSTAT023\***

Remote Minimum Position Potentiometer is used to remotely specify the minimum economizer position.







60 Hz units with standard options are certified by Underwriters Laboratory.

Trane optimizes the performance of homes and buildings around the world. A business of Ingersoll Rand, the leader in creating and sustaining safe, comfortable and energy efficient environments, Trane offers a broad portfolio of advanced controls and HVAC systems, comprehensive building services, and parts. For more information, visit [www.Trane.com](http://www.Trane.com).

Trane has a policy of continuous product and product data improvement and reserves the right to change design and specifications without notice.